



Yucaipa Valley Water District

12770 Second Street, Yucaipa, California 92399 Phone: (909) 797-5117

Notice and Agenda of a Meeting of the Board of Directors

November 16, 2021 at 4:00 p.m.

**This meeting is available by calling (888) 475-4499
Meeting ID: 676-950-731#**

Participate in the meeting online at

<https://zoom.us/j/676950731>

Passcode: 765589

**There will be no public physical location
available to attend this meeting in person.**

- I. CALL TO ORDER**
- II. ROLL CALL**
- III. PUBLIC COMMENTS** - At this time, members of the public may briefly address the Board of Directors on matters within its jurisdiction or on any matter listed on this agenda.
- IV. CONSENT CALENDAR** - All consent calendar matters are routine and will be acted upon in one motion. There will be no discussion of these items unless board members, administrative staff, or members of the public request specific items to be discussed and/or removed prior to the vote for approval.
 - A. Adoption of Resolution No. 2021-53 Proclaiming a Local Emergency, Ratifying the Proclamation of a State of Emergency by Governor Newsom on March 4, 2020, and Authorizing Remote Teleconference Meetings of the Legislative Bodies of the Yucaipa Valley Water District for the Period of December 1, 2021 to December 30, 2021 Pursuant to Brown Act Provisions
 - B. Minutes of Meetings
 - 1. Board Meeting – November 2, 2021
 - C. Payment of Bills
 - 1. Approve/Ratify Invoices for Board Awarded Contracts
 - 2. Ratify General Expenses for October 2021

Any person who requires accommodation to participate in this meeting should contact the District office at (909) 797-5117, at least 48 hours prior to the meeting to request a disability-related modification or accommodation.

Materials that are provided to the Board of Directors after the meeting packet is compiled and distributed will be made available for public review during normal business hours at the District office located at 12770 Second Street, Yucaipa. Meeting materials are also available on the District's website at www.yvwd.dst.ca.us

V. STAFF REPORT

VI. DISCUSSION ITEMS

- A. Presentation of Financial Goals and the Creation of a Joint Exercise of Powers Agreement for the Formation of the Yucaipa Valley Water District Financing Authority [[Director Memorandum No. 21-177 - Page 20 of 172](#)]
RECOMMENDED ACTION: Presentation - No Recommendation at this time.
- B. Presentation of the Unaudited Financial Report for the Period Ending on October 31, 2021 [[Director Memorandum No. 21-178 - Page 34 of 172](#)]
RECOMMENDED ACTION: That the Board receive and file the unaudited financial report.
- C. Status Report on the Installation of a Temporary 4-Inch HDPE High-Line Near Knoll Drive, Yucaipa [[Director Memorandum No. 21-179 - Page 60 of 172](#)]
RECOMMENDED ACTION: Staff presentation - no action required.
- D. Consideration of Proposal from Redistricting Insights for Professional Services Related to the Revision of Division Boundaries [[Director Memorandum No. 21-180 - Page 64 of 172](#)]
RECOMMENDED ACTION: That the Board authorize the General Manager to execute a contract with Redistricting Insights for a sum not to exceed \$10,000.
- E. Consideration to Purchase Four Service Trucks for the Public Works Department [[Director Memorandum No. 21-181 - Page 72 of 172](#)]
RECOMMENDED ACTION: That the Board authorize the purchase of vehicles from Transwest Truck Center for a sum not to exceed \$414,134.95 and adopt Resolution No. 2021-54 Transferring Reserve Funds for the vehicle purchase.
- F. Review and Discussion about the Draft Request for Proposals for Professional Public Relations Services for Calendar Year 2022 [[Director Memorandum No. 21-182 - Page 133 of 172](#)]
RECOMMENDED ACTION: That the Board authorize the General Manager to finalize and distribute the Request for Proposals.
- G. Consideration of Resolutions Authorizing the Grant Application, Acceptance and Execution for Various Projects for Funding from the Urban and Multibenefit Drought Relief Program [[Director Memorandum No. 21-183 - Page 154 of 172](#)]
RECOMMENDED ACTION: That the Board adopts Resolution Nos. 2021-55, 2021-56, 2021-57, and 2021-58.

VII. BOARD REPORTS & DIRECTOR COMMENTS

VIII. ANNOUNCEMENTS

- A. December 7, 2021 at 4:00 p.m. - Board Meeting
- B. December 21, 2021 at 4:00 p.m. - Board Meeting
- C. **January 4, 2022 at 4:00 p.m. - Meeting Cancelled**
- D. January 18, 2022 at 4:00 p.m. - Board Meeting
- E. February 1, 2022 at 4:00 p.m. - Board Meeting
- F. February 15, 2022 at 4:00 p.m. - Board Meeting
- G. March 1, 2022 at 4:00 p.m. - Board Meeting
- H. March 15, 2022 at 4:00 p.m. - Board Meeting

IX. ADJOURNMENT

Consent Calendar



Yucaipa Valley Water District

RESOLUTION NO. 2021-53

A RESOLUTION OF THE BOARD OF DIRECTORS OF THE YUCAIPA VALLEY WATER DISTRICT PROCLAIMING A LOCAL EMERGENCY, RATIFYING THE PROCLAMATION OF A STATE OF EMERGENCY BY GOVERNOR NEWSOM ON MARCH 4, 2020, AND AUTHORIZING REMOTE TELECONFERENCE MEETINGS OF THE LEGISLATIVE BODIES OF THE YUCAIPA VALLEY WATER DISTRICT FOR THE PERIOD OF DECEMBER 1, 2021 TO DECEMBER 30, 2021 PURSUANT TO BROWN ACT PROVISIONS

WHEREAS, the Yucaipa Valley Water District is committed to preserving and nurturing public access and participation in meetings of the Board of Directors; and

WHEREAS, all meetings of the Yucaipa Valley Water District's legislative bodies are open and public, as required by the Ralph M. Brown Act (Cal. Gov. Code 54950 – 54963), so that any member of the public may attend, participate, and watch the District's legislative bodies conduct their business; and

WHEREAS, the Brown Act, Government Code section 54953(e), makes provisions for remote teleconferencing participation in meetings by members of a legislative body, without compliance with the requirements of Government Code section 54953(b)(3), subject to the existence of certain conditions; and

WHEREAS, a required condition is that a state of emergency is declared by the Governor pursuant to Government Code section 8625, proclaiming the existence of conditions of disaster or of extreme peril to the safety of persons and property within the state caused by conditions as described in Government Code section 8558; and

WHEREAS, a proclamation is made when there is an actual incident, threat of disaster, or extreme peril to the safety of persons and property within the jurisdictions that are within the District's boundaries, caused by natural, technological, or human-caused disasters; and

WHEREAS, it is further required that state or local officials have imposed or recommended measures to promote social distancing, or, the legislative body meeting in person would present imminent risks to the health and safety of attendees; and

WHEREAS, such conditions now exist in the District, specifically, a state of emergency has been proclaimed due to an outbreak of respiratory illness due to a novel coronavirus (a disease now known as COVID-19); and

WHEREAS, the San Bernardino County Department of Health has recommended measures to promote social distancing; and

WHEREAS, the Board of Directors has determined that the state of emergency continues to directly impact the ability of the members to meet safely in person; and

WHEREAS, the Board of Directors does hereby find that the current state of emergency with

respect to COVID-19, local official recommendations to promote social distancing, and conditions causing imminent risk to the health and safety of attendees have caused, and will continue to cause, conditions of peril to the safety of persons within the District that are likely to be beyond the control of services, personnel, equipment, and facilities of the District, and desires to proclaim a local emergency and ratify the proclamation of state of emergency by the Governor of the State of California; and

WHEREAS, as a consequence of the local emergency, the Board of Directors does hereby find that the legislative bodies of the Yucaipa Valley Water District shall conduct their meetings without compliance with paragraph (3) of subdivision (b) of Government Code section 54953, as authorized by subdivision (e) of section 54953, and that such legislative bodies shall comply with the requirements to provide the public with access to the meetings as prescribed in paragraph (2) of subdivision (e) of section 54953;

NOW, THEREFORE, THE BOARD OF DIRECTORS OF THE YUCAIPA VALLEY WATER DISTRICT DOES HEREBY RESOLVE AS FOLLOWS:

- Section 1. Recitals. The Recitals set forth above are true and correct and are incorporated into this Resolution by this reference.
- Section 2. Proclamation of Local Emergency. The Board hereby proclaims that a local emergency now exists throughout the District and declares that meeting in person would not comply with local official recommendations to promote social distancing and would present imminent risk to the health and safety of attendees.
- Section 3. Ratification of Governor's Proclamation of a State of Emergency. The Board hereby ratifies the Governor of the State of California's Proclamation of a State of Emergency, effective as of its issuance date of March 4, 2020.
- Section 4. Remote Teleconference Meetings. The General Manager and legislative bodies of the Yucaipa Valley Water District are hereby authorized and directed to take all actions necessary to carry out the intent and purpose of this Resolution including, conducting open and public meetings in accordance with Government Code section 54953(e) and other applicable provisions of the Brown Act.
- Section 5. Effective Date of Resolution. This Resolution shall be effective for the thirty (30) day period identified in the title of this Resolution, or such time the Board of Directors adopts a subsequent resolution amending the thirty day period in accordance with Government Code section 54953(e)(3) during which the legislative bodies of the Yucaipa Valley Water District may continue to teleconference without compliance with paragraph (3) of subdivision (b) of section 54953.

PASSED AND ADOPTED by the Board of Directors of the Yucaipa Valley Water District, this 17th day of November 2021.

YUCAIPA VALLEY WATER DISTRICT

Chris Mann, President Board of Directors

ATTEST:

Joseph B. Zoba, General Manager

MINUTES OF A SPECIAL BOARD MEETING - TELECONFERENCE

November 2, 2021 at 4:00 pm

Directors Present:

Chris Mann, President
Jay Bogh, Director
Joyce McIntire, Director
Nyles O’Harra, Director

Staff Present:

Wade Allsup, Information Systems Specialist
Jennifer Ares, Water Resource Manager
Madeline Blua, Water Resource Specialist
Allison Edmisten, Chief Financial Officer
Ashley Gibson, Regulatory Compliance Manager
Dustin Hochreiter, Senior Engineering Technician
Mike Kostelecky, Operations Manager
Matthew Porras, Implementation Manager
Mike Rivera, Public Works Manager
Charles Thomas, Operations Manager
Joseph Zoba, General Manager

Directors Absent:

Lonni Granlund, Vice President

Consulting Staff Present:

Steven Graham, Legal Counsel

Registered Guests and Others Present:

Michelle Lopez, News Mirror
Larry Smith, San Gorgonio Pass Water Agency

This meeting was available to the public by calling (888) 475-4499 using passcode 676-950-731 and live presentation of the meeting was available at <https://zoom.us/j/676950731> using 765589.

CALL TO ORDER

The special meeting of the Board of Directors of the Yucaipa Valley Water District was called to order by Chris Mann at 4:00 p.m.

ROLL CALL

The roll was called with Director Jay Bogh, Director Chris Mann, Director Joyce McIntire, and Director Nyles O’Harra present.

Director Lonni Granlund was absent.

PUBLIC COMMENTS

None

CONSENT CALENDAR

Director Jay Bogh moved to approve the consent calendar and Director Nyles O’Harra seconded the motion.

A. Minutes of Meetings

1. Board Meeting – October 19, 2021

The motion was approved by the following vote:

- Director Jay Bogh - Yes
- Director Lonni Granlund - Absent
- Director Chris Mann - Yes
- Director Joyce McIntire - Yes
- Director Nyles O’Harra - Yes

STAFF REPORT

General Manager Joseph Zoba reported on the following items:

- The District has started the installation of the temporary above ground water line for customers on Knoll Drive. This temporary pipeline will allow the District to eliminate the old pipeline that crosses several properties to serve the area. A new replacement pipeline to be located in the roadway is currently being designed and will be constructed in the near future.
- The Upper Santa Ana River Watershed Infrastructure Financing Authority will be meeting on November 3, 2021 at 8:30 am.
- The San Gorgonio Pass Regional Water Alliance will be meeting on November 3, 2021 at 5:00 pm.
- The District will be hosting a Community Water Meeting on November 8, 2021 at 6:00 pm to discuss the drought and other water resource management issues.

DISCUSSION ITEMS:

DM 21-174

CONSIDERATION OF
RESOLUTION NO. 2021-51
UPDATING THE
CALCULATION FOR FACILITY
CAPACITY CHARGES
RELATED TO THE PURCHASE
OF PERMANENT
SUPPLEMENTAL WATER
RESOURCES FOR NEW
DEVELOPMENT WITHIN
RIVERSIDE COUNTY

General Manager Joseph Zoba provided an overview of Resolution No. 2021-51 regarding the calculation of Facility Capacity Charges for new construction in Riverside County. This item was continued from the board meeting on October 19, 2021.

Director Nyles O’Harra moved that the Board adopt Resolution No. 2021-51.

Director Joyce McIntire seconded the motion.

The motion was approved by the following vote:

- Director Jay Bogh - Yes
- Director Lonni Granlund - Absent
- Director Chris Mann - Yes

Director Joyce McIntire - Yes
Director Nyles O’Harra - Yes

DM 21-175

CONSIDERATION OF A
PAVING AGREEMENT WITH
THE CITY OF YUCAIPA FOR
BELLA VISTA, LEITH WAY AND
LINCOLN DRIVE

Public Works Manager Mike Rivera provided an overview of the proposed paving agreement between the City of Yucaipa and the Yucaipa Valley Water District.

Director Joyce McIntire moved that the Board authorize the General Manager to execute Paving Agreement No. 2021-17.

Director Jay Bogh seconded the motion.

The motion was approved by the following vote:

Director Jay Bogh - Yes
Director Lonni Granlund - Absent
Director Chris Mann - Yes
Director Joyce McIntire - Yes
Director Nyles O’Harra - Yes

DM 21-176

CONSIDERATION OF
RESOLUTION NO. 2021-52
ESTABLISHING EMPLOYEE
BENEFIT, ADMINISTRATIVE
OVERHEAD AND SURCHARGE
FACTORS

Chief Financial Officer Allison Edmisten provided an overview of Resolution No. 2021-52 regarding the calculation of various billable factors related to employee benefits, administrative overhead, and surcharges for processing contractor/consultant invoices.

Director Nyles O’Harra moved that the Board adopt Resolution No. 2021-52.

Director Joyce McIntire seconded the motion.

The motion was approved by the following vote:

Director Jay Bogh - Yes
Director Lonni Granlund - Absent
Director Chris Mann - Yes
Director Joyce McIntire - Yes
Director Nyles O’Harra - Yes

BOARD REPORTS AND
DIRECTOR COMMENTS

Director Joyce McIntire reported on the Riverside County Water Task Force meeting held on October 22, 2021.

Director Joyce McIntire reported on the San Gorgonio Pass Water Agency meeting held on October 25, 2021.

Director Nyles O’Harra reported on the overall redistricting process by Yucaipa Valley Water District and the overall accomplishments by the District.

ANNOUNCEMENTS

Chris Mann called attention to the announcements listed on the agenda.

ADJOURNMENT

The meeting was adjourned at 4:20 p.m.

Respectfully submitted,

Joseph B. Zoba, Secretary

(Seal)

Board Awarded Contracts
Consent Calendar Board Meeting - November 16, 2021

District Awarded Contracts	Director Memorandum	Job or GL #	Job Cost Breakdown	Awarded Contract Amount	Prior Payments to Date	Pending Invoice Amount	Total Contract Payments	Remaining Contract Amount
Cole Huber LLP	--	*-5-06-54107	--	--	\$0	\$4,500	\$4,500	
APGN Inc. WWTP Secondary Treatment- turbo blowers/bubble diffusers	21-085	03-000-14500 Task #87041	--	\$768,520	\$357,689	\$308,019	\$665,708	\$102,812
DDB Engineering (R-Reserves) Application to DDW for the Recharge at Wilson Creek Basins	15-086	04-19771	--	\$35,900	\$25,395	\$0	\$25,395	\$10,505
Delta Ventures, Inc \$90,000 per year-Legislative Consult (exp 12/18) WIS Oper Three Year Contract Extension (exp 12/2021)	13-079 19-052	*-5-06-54109 *5-06-54109	\$90,000 \$270,000	\$360,000	\$307,500	\$7,500	\$315,000	\$45,000
Dudek (S-Operating) 2020-2021 Max Benefit Monitoring for San Timoteo/Yucaipa Mgmt. Zones	20-038	03-5-06-54109	--	\$52,338	\$50,641	\$0	\$50,641	\$1,697
Dudek (S-Operating) 2021-2022 Max Benefit Monitoring for San Timoteo/Yucaipa Mgmt. Zones	21-101	03-5-06-54109	--	\$47,764	\$6,995	\$1,398	\$8,393	\$39,372
Dudek (S-Operating) 2020 -Habitat Monitoring Program (HMP) in San Timoteo Creek	20-037	65-15339 03-5-06-57030	--	\$52,660	\$50,330	\$0	\$50,330	\$2,330
ECORP (W/S Reserves) Prepare Study/Mitigated Negative Declaration/Oak Valley Recharge DM 19-039 Ratification of original contract-addt'l sum not to exceed \$4500.00	02-5-06-54109 18-157 19-093	77-32719	\$47,520 \$4,500	\$52,020	\$25,974	\$0	\$25,974	\$26,046
ECORP (W/S Reserves) YVWD-Salinity and Groundwater Enhancement (Sage) Project W/S Reserves	03-502-51003 19-022	88-23792		\$9,645	\$266	\$0	\$266	\$9,379
E.J. Meyer Company Interstate 10 Sewer Crossing	21-149	03-000-14500 Task #81883	--	\$959,999	\$0	\$88,576	\$88,576	\$871,423
Geoscience Injection and Monitoring Well for Aquifer Storage/Beaumont Basin	21-031	03-5-06-54109	--	\$450,818	\$41,746	\$700	\$42,446	\$408,373
Geoscience Tracer Study Analysis at Wilson Creek Spreading Basins (\$34,560.00) DM 20-008 Budget Amendment for the Tracer Study (\$7,930.00)_	19-024 20-008	02-5-06-54109	--	\$42,490	\$36,222	\$0	\$36,222	\$6,268
GHD SCADA Master Planning Document for WWTP	21-062	03-506-54109	--	\$78,090	\$20,721	\$0	\$20,721	\$57,369
One Stop Landscape Supply FY 20-21 Sludge Hauling\Reuse (Oper)	--	03-5-02-57031	--	--	\$264,371	\$22,200	\$286,571	

Board Awarded Contracts
Consent Calendar Board Meeting - November 16, 2021

District Awarded Contracts	Director Memorandum	Job or GL #	Job Cost Breakdown	Awarded Contract Amount	Prior Payments to Date	Pending Invoice Amount	Total Contract Payments	Remaining Contract Amount
RMC Water & Environment/ Woodard & Curran TO#26, SRF Mgmt. Svcs-Calimesa Regional Recycled Pipeline (R-FCC)	14-023	04-5-06-54109		\$95,692	\$69,361	\$0	\$69,361	\$26,331
Separation Processes, Inc. (W-Reserves) Design & Construction Supports Servs for NF SCRAM	15-047	55-19200 02-14500		\$191,820	\$170,980	\$0	\$170,980	\$20,840
Application to DDW for the Recharge at Wilson Creek Basins (R-Resrvs)	15-086	04-19771	--	\$42,860	\$24,527	\$0	\$24,527	\$18,333
Feasibility Report for Wochholz SAGE Project (\$67,575.00) Preliminary Engineering Design Study-SAGE Project (\$32,260.00)	17-043 19-106	03-5-06-54109 03-5-06-54109		\$99,835	\$98,311	\$0	\$98,311	\$1,524
WWTP Monitoring Operations & Reporting Enhancement (MORE) (S-Oper)	18-122	03-5-06-54109		\$330,436	\$311,698	\$0	\$311,698	\$18,738
WWTP -RCA - Foaming- Improve energy efficiency and treatment process	19-025	03-5-06-54109		\$36,800	\$34,621	\$0	\$34,621	\$2,179
WWTP -Secondary Treatment Process Improvement	20-073	03-5-06-54109		\$158,753	\$149,245	\$1,180	\$150,425	\$8,328
WWTP - Reverse Osmosis Pilot Study	20-099	03-5-06-54109		\$192,860	\$47,599	\$816	\$48,415	\$144,445
Spiess Construction Reservoir R-17.1.1 & R-17.1.2 Replacement	21-090	02-000-14500 Task #90857	--	\$1,701,725	\$209,505	\$152,373	\$361,878	\$1,339,847
WWTP- Autostrainer Replacement (Sewer Reserves) Pascal Ludwig-\$229,111.00 Forstra Filters -\$152,208.00 Q-Versa- \$28,800.00	20-132	03-13002		\$487,000	\$409,899	\$0	\$409,899	\$77,101
GRAND TOTALS				\$5,761,025	\$2,303,697	\$587,261	\$2,890,958	\$3,238,239

Check Register - October 2021

Date	Check #	Payee or Description	Amount
10/04/2021	39966	ADS, LLC	\$ 6,210.00
10/04/2021	39967	Alpine Springs	\$ 92.45
10/04/2021	39968	Aramark Uniform and Career Apparel, LLC	\$ 843.45
10/04/2021	39969	AutoZone Stores LLC	\$ 32.61
10/04/2021	39970	Best Home Center	\$ 75.85
10/04/2021	39971	BofA Credit Card	\$ 2,738.29
10/04/2021	39972	Burgeson's Heating & Air Cond. Inc	\$ 980.00
10/04/2021	39973	California Water Environment Association	\$ 192.00
10/04/2021	39974	Center Electric Services, Inc.	\$ 1,935.00
10/04/2021	39975	Charles Wayne Hippenstiel	\$ 3,320.00
10/04/2021	39976	Coverall North America, Inc.	\$ 805.00
10/04/2021	39977	Crown Ace Hardware - Yucaipa	\$ 409.02
10/04/2021	39978	FMB Truck Outfitters, Inc.	\$ 142.87
10/04/2021	39979	G&G Environmental Compliance, Inc	\$ 3,069.70
10/04/2021	39980	Hemet Valley Tool Inc.	\$ 952.80
10/04/2021	39981	Houston & Harris PCS, Inc.	\$ 1,973.25
10/04/2021	39982	JW D'Angelo Co.	\$ 711.76
10/04/2021	39983	King Lee Chemical, Co.	\$ 16,930.87
10/04/2021	39984	Krieger & Stewart, Incorporated	\$ 112,668.70
10/04/2021	39985	LUZ Investment Corp.	\$ 750.00
10/04/2021	39986	Merit Oil Company	\$ 7,784.45
10/04/2021	39987	NetComp Technologies, Inc.	\$ 300.00
10/04/2021	39988	Ryan Herco Products Corp	\$ 268.82
10/04/2021	39989	San Bdn. Valley Muni. Water Dist.	\$ 37,918.60
10/04/2021	39990	SB CNTY-Treasurer-Tax	\$ 55.55
10/04/2021	39991	Superior Automotive Warehouse, Inc	\$ 14.18
10/04/2021	39992	The Dickson Company	\$ 1,896.53
10/04/2021	39993	The Gas Company	\$ 95.15
10/04/2021	39994	TPX Communications	\$ 2,238.72
10/04/2021	39995	Underground Service Alert Of So. CA	\$ 531.40
10/04/2021	39996	UPS Store#1504/ Mail Boxes Etc.	\$ 51.22
10/04/2021	39997	US Bank	\$ 18,977.24
10/04/2021	39998	Water Systems Optimization Inc.	\$ 2,500.00
10/04/2021	39999	Xpress Bill Pay	\$ 698.25
10/04/2021	40000	Yucaipa Disposal, Inc.	\$ 2,502.83
10/04/2021	40001	Yucaipa Valley Water District	\$ 69,401.54
10/04/2021	40002	Assoc. SB Cty Special Districts	\$ 30.00
10/08/2021	40003	California State Disbursement Unit	\$ 628.14
10/08/2021	40004	IBEW Local #1436	\$ 660.00
10/08/2021	40005	WageWorks Inc	\$ 1,686.89
10/11/2021	40006	California FAIR Plan	\$ 4,953.00
10/11/2021	40007	Aramark Uniform and Career Apparel, LLC	\$ 834.64
10/11/2021	40008	Bay Alarm Company	\$ 259.52
10/11/2021	40009	Brenntag Pacific, Inc	\$ 17,697.51
10/11/2021	40010	Burgeson's Heating & Air Cond. Inc	\$ 225.00

Check Register - October 2021

Date	Check #	Payee or Description	Amount
10/11/2021	40011	Caselle, Inc.	\$ 2,870.00
10/11/2021	40012	Center Electric Services, Inc.	\$ 1,311.00
10/11/2021	40013	City of Redlands	\$ 625.00
10/11/2021	40014	Clinical Laboratory of San Bernardino	\$ 40,492.50
10/11/2021	40015	Corelogic, Inc.	\$ 330.00
10/11/2021	40016	Coverall North America, Inc.	\$ 526.00
10/11/2021	40017	Crown Ace Hardware - Yucaipa	\$ 9.24
10/11/2021	40018	Dudek & Associates, Inc	\$ 750.00
10/11/2021	40019	Epic Pest Management	\$ 85.00
10/11/2021	40020	Freedom Mailing Services	\$ 8,510.57
10/11/2021	40021	Frontier Communications	\$ 170.65
10/11/2021	40022	Joe Zambetti	\$ 315.28
10/11/2021	40023	JW D'Angelo Co.	\$ 40,216.97
10/11/2021	40024	Konica Minolta Business Solutions	\$ 267.39
10/11/2021	40025	Les Schwab Tire Center	\$ 152.50
10/11/2021	40026	Q Versa, LLC	\$ 6,358.28
10/11/2021	40027	RAIN FOR RENT	\$ 4,871.56
10/11/2021	40028	REVIZE SOFTWARE SYSTEMS	\$ 1,800.00
10/11/2021	40029	San Bdn. Valley Muni. Water Dist.	\$ 37,146.29
10/11/2021	40030	SCHWING BIOSET, INC	\$ 750.24
10/11/2021	40031	Separation Processes, Inc.	\$ 13,084.22
10/11/2021	40032	South Coast A.Q.M.D.	\$ 14,011.36
10/11/2021	40033	Time Warner Cable	\$ 1,719.58
10/11/2021	40034	UPS Store#1504/ Mail Boxes Etc.	\$ 25.80
10/11/2021	40035	Watereuse Association	\$ 2,205.00
10/11/2021	40036	Clark Pest Control	\$ 118.00
10/11/2021	40037	Crown Ace Hardware - Yucaipa	\$ 267.90
10/11/2021	40038	DWS Advantage	\$ 2,278.14
10/11/2021	40039	Houston & Harris PCS, Inc.	\$ 1,973.25
10/11/2021	40040	Merit Oil Company	\$ 1,499.62
10/11/2021	40041	Nexa	\$ 675.00
10/11/2021	40042	Office Solutions Bsns Products, L	\$ 1,061.61
10/11/2021	40043	Pollardwater	\$ 287.66
10/11/2021	40044	Track Technologies	\$ 12,000.00
10/18/2021	40045	Delta Ventures Inc.	\$ 7,500.00
10/18/2021	40046	Dudek & Associates, Inc	\$ 3,076.25
10/18/2021	40047	Geoscience Support Services, Inc.	\$ 1,299.75
10/18/2021	40048	One Stop Landscape Supply Inc	\$ 20,802.50
10/18/2021	40049	Separation Processes, Inc.	\$ 8,738.37
10/18/2021	40050	Spiess Construction Company Inc	\$ 68,290.10
10/22/2021	40051	California State Disbursement Unit	\$ 628.14
10/22/2021	40052	WageWorks Inc	\$ 1,686.89
10/22/2021	40053	Alpine Springs	\$ 77.45
10/22/2021	40054	American Water Works Assoc.	\$ 302.00

Check Register - October 2021

Date	Check #	Payee or Description	Amount
10/22/2021	40055	Aqua-Metric Sales Company	\$ 59,582.67
10/22/2021	40056	Aramark Uniform and Career Apparel, LLC	\$ 840.79
10/22/2021	40057	AT&T Mobility	\$ 2,096.92
10/22/2021	40058	AutoZone Stores LLC	\$ 246.66
10/22/2021	40059	B.L. Wallace Distributor Inc.	\$ 1,110.17
10/22/2021	40060	Beaumont Basin Watermaster	\$ 1,340.00
10/22/2021	40061	BofA Credit Card	\$ 1,999.91
10/22/2021	40062	Brenntag Pacific, Inc	\$ 34,614.55
10/22/2021	40063	Contron Scada Systems	\$ 2,962.41
10/22/2021	40064	Crown Ace Hardware - Yucaipa	\$ 208.94
10/22/2021	40065	Davis Farr LLP	\$ 15,000.00
10/22/2021	40066	Doan and Hartwig Water Systems, Inc.	\$ 5,884.32
10/22/2021	40067	ECORP Consulting, Inc.	\$ 2,395.00
10/22/2021	40068	Evoqua Water Technologies LLC	\$ 2,449.53
10/22/2021	40069	Fastenal Company	\$ 1,685.61
10/22/2021	40070	G&G Environmental Compliance, Inc	\$ 3,834.44
10/22/2021	40071	Goldak Inc	\$ 164.09
10/22/2021	40072	Griswold Industries	\$ 5,061.77
10/22/2021	40073	Hasa, Inc.	\$ 8,234.26
10/22/2021	40074	Houston & Harris PCS, Inc.	\$ 1,973.25
10/22/2021	40075	Inland Kubota, Inc.	\$ 320.29
10/22/2021	40076	JW D'Angelo Co.	\$ 15,427.89
10/22/2021	40077	Les Schwab Tire Center	\$ 82.80
10/22/2021	40078	Lowe's Companies, Inc.	\$ 1,135.89
10/22/2021	40079	Merit Oil Company	\$ 7,228.83
10/22/2021	40080	NetComp Technologies, Inc.	\$ 600.00
10/22/2021	40081	Odyssey Power Corporation	\$ 2,775.00
10/22/2021	40082	Office Solutions Bsns Products, L	\$ 240.78
10/22/2021	40083	Patton Sales Corporation	\$ 3,002.02
10/22/2021	40084	POWERFLO PRODUCTS INC.	\$ 18,868.63
10/22/2021	40085	Pro-Pipe & Supply, Inc.	\$ 592.40
10/22/2021	40086	Quinn Company	\$ 56,287.64
10/22/2021	40087	SCE Rosemead	\$ 236,189.64
10/22/2021	40088	Spectrum Business	\$ 3,668.00
10/22/2021	40089	Summit Environmental Srvcs, Inc.	\$ 2,000.26
10/22/2021	40090	Superior Automotive Warehouse, Inc	\$ 191.09
10/22/2021	40091	The Counseling Team International	\$ 375.00
10/22/2021	40092	The Dickson Company	\$ 1,597.53
10/22/2021	40093	UGSI Chemical Feed, Inc.	\$ 3,788.53
10/22/2021	40094	US Bank	\$ 9,439.33
10/25/2021	40095	Atkinson, Andelson, Loya, Ruud & Romo	\$ 8,314.12
10/25/2021	40096	Cobb's Printing, LLC	\$ 161.63
10/25/2021	40097	Doug Earnest	\$ 685.14

Check Register - October 2021

Date	Check #	Payee or Description	Amount
10/25/2021	40098	Jesse McCartney	\$ 685.14
10/25/2021	40099	Joe DeSalliers	\$ 603.35
10/25/2021	40100	Peggy Little	\$ 685.14
10/25/2021	40101	Robert Wall	\$ 799.13
10/25/2021	40102	Taylor Corporation	\$ 96.26
10/25/2021	40103	WageWorks, Inc.	\$ 191.75
10/25/2021	40104	Aflac	\$ 2,576.53
10/25/2021	40105	Blue Shield of California	\$ 4,267.50
10/25/2021	40106	Nippon Life Insurance Co	\$ 2,711.77
10/25/2021	40107	Standard Dental Insurance Co	\$ 1,309.12
10/25/2021	40108	Standard Insurance Vision Plan	\$ 329.56
10/25/2021	40109	Western Dental Services Inc	\$ 154.98
10/25/2021	40110	All American Sewer Tools	\$ 1,759.15
10/25/2021	40111	Bay Alarm Company	\$ 374.52
10/25/2021	40112	Brenntag Pacific, Inc	\$ 6,715.05
10/25/2021	40113	BSK Associates	\$ 1,060.00
10/25/2021	40114	Burgeson's Heating & Air Cond. Inc	\$ 1,256.00
10/25/2021	40115	California Special Districts Association	\$ 8,195.00
10/25/2021	40116	California Water Environment Association	\$ 192.00
10/25/2021	40117	Crown Ace Hardware - Yucaipa	\$ 97.18
10/25/2021	40118	Doug's Filter Service, Inc.	\$ 400.00
10/25/2021	40119	Frontier Communications	\$ 46.25
10/25/2021	40120	Geoscience Support Services, Inc.	\$ 2,400.00
10/25/2021	40121	Grainger	\$ 552.66
10/25/2021	40122	Griswold Industries	\$ 14,031.58
10/25/2021	40123	Hasa, Inc.	\$ 3,628.79
10/25/2021	40124	Home Depot U.S.A. Inc	\$ 717.96
10/25/2021	40125	Houston & Harris PCS, Inc.	\$ 1,973.25
10/25/2021	40126	Jimmy Faucett	\$ 14.07
10/25/2021	40127	JW D'Angelo Co.	\$ 9,565.79
10/25/2021	40128	Kaseya US LLC	\$ 2,316.00
10/25/2021	40129	KnowBe4 Inc	\$ 5,795.28
10/25/2021	40130	Konica Minolta Business Solutions	\$ 279.66
10/25/2021	40131	Les Schwab Tire Center	\$ 82.80
10/25/2021	40132	McCall's Meter Sales & Service	\$ 1,303.43
10/25/2021	40133	Meritage Homes	\$ 67.34
10/25/2021	40134	Mission Communications, LLC	\$ 1,126.80
10/25/2021	40135	Mountain Gate LLC	\$ 21.13
10/25/2021	40136	Nearmap US Inc.	\$ 25,000.00
10/25/2021	40137	Pacwest Engineering Co., Inc.	\$ 42,522.00
10/25/2021	40138	Page Locksmith	\$ 66.09
10/25/2021	40139	Pro-Pipe & Supply, Inc.	\$ 1,280.50

Check Register - October 2021

Date	Check #	Payee or Description	Amount
10/25/2021	40140	Redline	\$ 21,381.18
10/25/2021	40141	Richmond American Homes	\$ 147.39
10/25/2021	40142	Riverside County Treasurer	\$ 197.62
10/25/2021	40143	SCE Rosemead	\$ 30.89
10/25/2021	40144	Southern CA Emergency Medicine, Inc.	\$ 75.00
10/25/2021	40145	Spectrum Business	\$ 2,649.00
10/25/2021	40146	State Water Resources Control Board	\$ 370.00
10/25/2021	40147	Stephanie Stachowski	\$ 15.08
10/25/2021	40148	TPX Communications	\$ 2,228.68
10/25/2021	40149	Track Technologies	\$ 8,000.00
			<u>\$ 1,345,212.94</u>
10/08/2021	electronic pmt	DIRECT DEPOSIT TOTAL	\$ 171,240.57
10/08/2021	electronic pmt	CalPERS 457 & Loan	\$ 27,903.92
10/08/2021	electronic pmt	CalPERS Retirement	\$ 33,793.83
10/08/2021	electronic pmt	EDD - State of California	\$ 14,296.32
10/08/2021	electronic pmt	IRS	\$ 73,290.40
10/08/2021	electronic pmt	VOYA 457 Retirement Plan	\$ 3,759.74
10/22/2021	electronic pmt	DIRECT DEPOSIT TOTAL	\$ 151,251.43
10/22/2021	electronic pmt	CalPERS 457 & Loan	\$ 24,905.23
10/22/2021	electronic pmt	CalPERS Retirement	\$ 32,853.75
10/22/2021	electronic pmt	EDD - State of California	\$ 12,252.26
10/22/2021	electronic pmt	IRS	\$ 63,078.16
10/22/2021	electronic pmt	VOYA 457 Retirement Plan	\$ 3,759.74
10/25/2021	electronic pmt	CalPERS Health Insurance	\$ 93,687.78
			<u>\$ 706,073.13</u>

Staff Report



Yucaipa Valley Water District

Discussion Items





Date: November 16, 2021 **Task:** Not Applicable

Prepared By: Joseph B. Zoba, General Manager
Allison M. Edmisten, Chief Financial Officer

Subject: Presentation of Financial Goals and the Creation of a Joint Exercise of Powers Agreement for the Formation of the Yucaipa Valley Water District Financing Authority

Recommendation: Presentation - No Recommendation at this time.

Over the past two decades, the Yucaipa Valley Water District constructed several large-scale capital improvement projects to integrate the drinking water, recycled water, sewer treatment, and brine disposal services provided to the community. The District has been able to secure grants, low interest loans, and public financing to fund these various capital improvements.

Water Resource Management Schematic for the Yucaipa Valley Water District

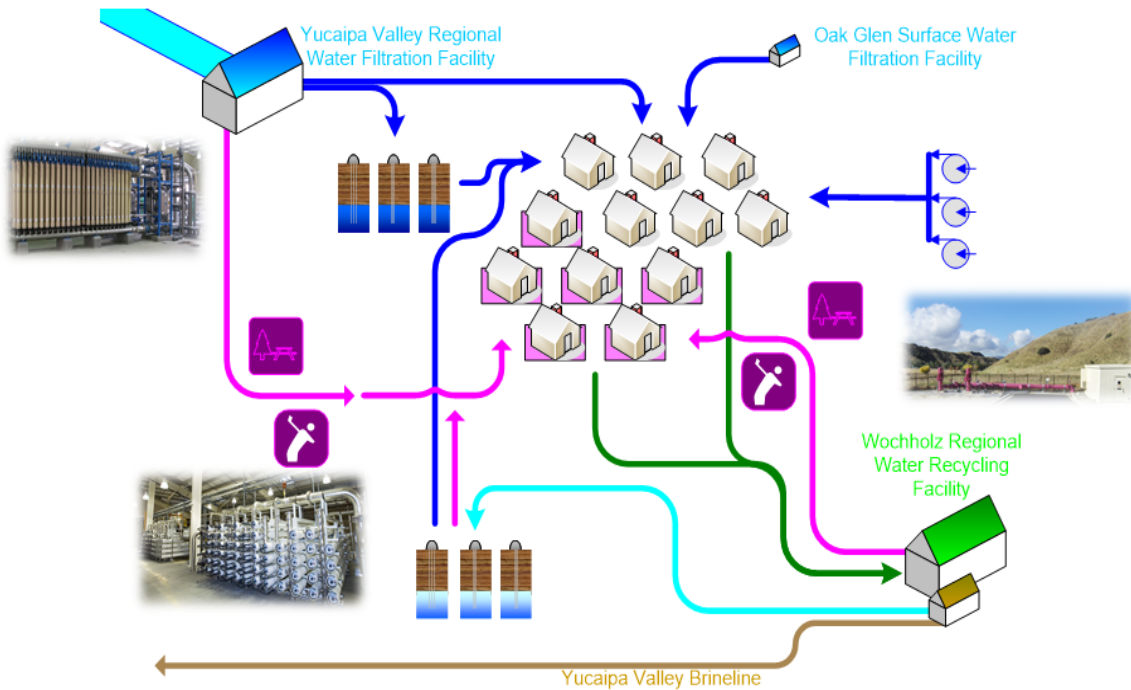

Background

On June 2, 2004, the Yucaipa Valley Water District created the Yucaipa Valley Water District Financing Corporation in anticipation of financing the construction of the Yucaipa Valley Regional Water Filtration Facility. On June 29, 2004, the Yucaipa Valley Water District Financing Corporation issued \$45,730,000 as Series 2004A Certificates of Participation for the construction of the new drinking water filtration facility. About ten years later on February 12, 2015, the Yucaipa Valley Water District refinanced the 2004A Certificates of Participation by issuing Water System Refunding Revenue Bonds as Series 2015A in the amount of \$30,810,000.

To provide financing for the sewer treatment plant, recycled water system, and brine disposal pipeline, the Yucaipa Valley Water District relied on low-interest State Revolving Fund Loans provided by the State Water Resources Control Board. The following State Revolving Fund loans have been secured by the District:

- Wochholz Regional Water Recycling Facility Expansion - In 2010, the District started the repayment of a State Revolving Fund loan (2.4% interest rate) in the amount of \$44,748,356 that was used for the expansion and upgrade of the Wochholz Regional Water Recycling Facility.
- Yucaipa Valley Regional Brineline – In 2014, the District started the repayment of a State Revolving Fund loan (2.7% interest rate) in the amount of \$9,752,100 for the construction of the Yucaipa Valley Regional Brineline. The total construction cost for this facility was \$19,706,156 which was also funded by several grants and cash.
- Wochholz Improved Salinity Effluent Project (W.I.S.E.) – In 2014, the District started the repayment of a State Revolving Fund loan (2.2% interest rate) in the amount of \$2,988,095 for the construction of the reverse osmosis equipment at the Wochholz Regional Water Recycling Facility to achieve compliance with the Regional Water Quality Control Board Basin Plan objectives. The construction cost for this facility was \$5,003,170 which was also funded by grants and cash.
- Recycled Water Reservoir R-10.3 – In 2014, the District started the repayment of a State Revolving Fund loan (2.2% interest rate) in the amount of \$871,570 for the construction of the Recycled Water Reservoir Complex R-10.3. The construction cost for this facility was \$4,177,087 which was also funded by grants and cash.
- Crow Street Recycled Water Pipeline and Booster B-12.1 – In 2016, the District started the repayment of a State Revolving Fund loan (2.2% interest rate) in the amount of \$310,179 for the construction of the Crow Street Recycled Water Pipeline and Recycled Water Booster Station B-12.1. The construction cost for this facility was \$2,972,167 which was also funded by grants and cash.
- Calimesa Recycled Water Pipeline Project - In 2021, the District received a State Revolving Fund loan (0.9% interest rate) and grant for \$1,758,750 for the expected project cost of \$5,785,000 to be used to construct the Calimesa Recycled Water Pipeline Project. This project will begin construction in early 2022.

Discussion

The Yucaipa Valley Water District has been working with our financial advisors from Fieldman Rolapp to develop a plan to review the current debt structure of the District and to continue to fund capital improvement projects that will improve water quality by expanding the reverse osmosis used to purify recycled water and expand the recycled water infrastructure throughout the community at low interest rates.

The Yucaipa Valley Water District is proposing to create the Yucaipa Valley Water District Financing Authority (Financing Authority) that would consist of a seven-member board - five elected officials from the Yucaipa Valley Water District and two elected officials from the San Bernardino Valley Municipal Water District. The Financing Authority, created by a separate and unique joint powers agreement, would assign all debt obligations, repayment obligations, and risk to the Yucaipa Valley Water District. From a financing perspective, the creation of the Financing Authority provides an opportunity for the Yucaipa Valley Water District to refinance the existing water division and sewer division debt obligations into a single combined debt of the Yucaipa Valley Water District.

At this meeting, the District's financial advisors, underwriters, and bond counsel will be providing an overview of the proposed financial plan to consolidate the existing debt while providing additional funding for the following projects:

- North Bench Recycled Water Facilities - The proposed expansion of the recycled water system on the North Bench would involve the construction of three recycled water reservoirs, three booster stations, and about 3.5 miles of recycled water pipelines.
- Salinity Concentrate Reduction and Minimization (SCRAM) Project - The Salinity Concentrate Reduction and Minimization (SCRAM) Project expands the existing microfiltration system from 13.6 million gallons per day to 19.4 million gallons per day by adding two additional microfiltration treatment systems. There will also be two additional nanofiltration systems to provide 6 million gallons per day of additional treatment. This proposed system will increase the nanofiltration system recovery from 85% to 95% saving an estimated 190 million gallons of water per year.
- Calimesa Lake Project - The Calimesa Lake Project is an important water feature associated with the Aquifer Storage and Recover System planned for the Calimesa area. While the proposed lake project will provide economic and aesthetic value for the community, the functionality of the lake will provide a water body for the routine operation and maintenance of the injection wells to avoid the discharge of recycled water to the local ephemeral streams.

*Stradling Yocca Carlson & Rauth
Draft of 11/9/21*

JOINT EXERCISE OF POWERS AGREEMENT

by and between

YUCAIPA VALLEY WATER DISTRICT

and

SAN BERNARDINO VALLEY MUNICIPAL WATER DISTRICT

creating the

YUCAIPA VALLEY WATER DISTRICT FINANCING AUTHORITY

December 7, 2021

4843-5280-4861v5/024636-0006

JOINT EXERCISE OF POWERS AGREEMENT

THIS AGREEMENT, dated December 7, 2021, by and between the YUCAIPA VALLEY WATER DISTRICT, a county water district that is duly organized and existing under and by virtue of the laws of the State of California, (“YVWD”), and SAN BERNARDINO VALLEY MUNICIPAL WATER DISTRICT, a municipal water district that is organized and existing under and by virtue of the laws of the State of California (“SBVMWD”).

DECLARATION OF PURPOSE

A. Chapter 5 of Division 7 of Title 1 of the California Government Code (the “Act”) authorizes YVWD and SBVMWD to create a joint exercise of powers entity which has the power to exercise any powers common to YVWD and SBVMWD and to exercise additional powers granted to it under the Act. This Agreement creates such an agency, which shall be known as the Yucaipa Valley Water District Financing Authority (the “Authority”) for the purposes and to exercise the powers described herein.

B. YVWD and SBVMWD are each authorized to buy, sell, lease and use property and to incur indebtedness for public purposes pursuant to the California Water Code, the California Government Code and other laws of the State of California.

C. Article 4 of the Act (known as the “Marks-Roos Local Bond Pooling Act of 1985”) authorizes and empowers the Authority to issue bonds and to purchase bonds issued by, or to make loans to, YVWD or SBVMWD for financing public capital improvements, working capital, liability and other insurance needs, or projects whenever there are significant public benefits, as determined by the Authority. The Marks-Roos Local Bond Pooling Act of 1985 further authorizes and empowers the Authority to sell bonds so issued or purchased to public or private purchasers at public or negotiated sale.

TERMS OF AGREEMENT

Section 1. Definitions. Unless the context otherwise requires, the terms defined in this Section 1 shall for all purposes of this Agreement have the meanings herein specified.

“Act” shall mean Articles 1, 2 and 4 of Chapter 5 of Division 7 of Title 1 of the California Government Code, as amended.

“Agreement” shall mean this Joint Exercise of Powers Agreement, as it may be amended from time to time, creating the Authority.

“Authority” shall mean the Yucaipa Valley Water District Financing Authority created by this Agreement.

“Board” or “Board of Directors” shall mean the governing board of the Authority.

“Bonds” shall mean bonds and any other evidences of indebtedness of the Authority authorized and issued pursuant to the Act.

“*Indenture*” shall mean each indenture, trust agreement, resolution or other such instrument pursuant to which Bonds are issued.

“*Local Agency*” shall mean YVWD or any other public agency which enters into a Security Agreement with the Authority.

“*Members*” shall mean YVWD and SBVMWD.

“*Security Agreement*” means any installment purchase agreement, lease agreement, payment agreement or other agreement which in each case obligates a Local Agency to pay all or a portion of the principal and interest on Bonds.

“*State*” shall mean the State of California.

Section 2. Purpose. This Agreement is made pursuant to the Act for the purpose of assisting in the financing and refinancing of capital improvement projects of the Local Agencies, working capital for the Local Agencies and other costs described in the Act by exercising the powers referred to in this Agreement. Any Bonds issued by the Authority shall be solely for projects benefiting the Local Agency or Local Agencies entering into a Security Agreement with respect to such Bonds.

Section 3. Term. This Agreement shall become effective as of the date hereof and shall continue in full force and effect until the Members terminate this Agreement in writing; provided however this Agreement shall not terminate so long as any Bonds or other obligations of the Authority remain outstanding under the terms of any indenture, trust agreement, contract, agreement, lease, sublease or other instrument pursuant to which such Bonds are issued or other obligations are incurred.

Section 4. The Authority.

(a) *Creation of the Authority.* There is hereby created pursuant to the Act an authority and public entity to be known as the “Yucaipa Valley Water District Financing Authority.” As provided in the Act, the Authority shall be a public entity separate from the Members. The geographic boundaries of the Authority shall be coextensive with the boundaries of the Members. The debts, liabilities and obligations of the Authority shall not constitute debts, liabilities or obligations of the Members. Notwithstanding any other provision of this Agreement, the Authority shall not have the power to incur any debt, liability or obligation that is not subject to the preceding sentence, including but not limited to any debt, liability or obligation to a public retirement system or otherwise for pension, health care or other retirement benefits.

Within 30 days after the effective date of this Agreement or any amendment hereto, the Authority will cause a notice of this Agreement or amendment to be prepared and filed with the office of the Secretary of State of the State in the manner that is set forth in Section 6503.5 of the Act. Such notice shall also be filed with the office of the Finance Director of the State.

(b) *Governing Board.* The Authority shall be administered by the Board, which shall consist of five members appointed by YVWD and two members appointed by SBVMWD. The term of office as a member of the Board shall terminate when such member of the Board shall cease to hold his or her respective office at YVWD or SBVMWD, as applicable, and the successor to such

officer or director of YVWD or SBVMWD, as applicable, shall become a member of the Board, upon assuming such office.

Members of the Board shall not receive any compensation for serving as such, but shall be entitled to reimbursement for any expenses actually incurred in connection with serving as a member if the Board shall determine that such expenses shall be reimbursed and there are unencumbered funds available for such purpose.

(c) Meetings of Board.

(1) The Board shall hold regular meetings on the first and third Tuesdays of each calendar month at 6:00 P.M. at the offices of YVWD unless the Board determines to meet at an alternate location in accordance with California law. The Board may suspend the holding of regular meetings so long as there is no need for Authority business. The Board may hold special meetings at any time and from time to time in accordance with law, provided that, so long as required by the Act, any action taken regarding the sale of Bonds shall occur by resolution placed on a noticed and posted meeting agenda for a regular meeting of the Authority.

(2) All regular and special meetings of the Board shall be called, noticed, held and conducted subject to the provisions of the Ralph M. Brown Act (Chapter 9 of Part 1 of Division 2 of Title 5 of the California Government Code), or any successor legislation hereafter enacted.

(3) The Secretary of the Authority shall cause minutes of all meetings of the Board to be kept and shall, as soon as practicable after each meeting, cause a copy of the minutes to be forwarded to each member of the Board and to the Members.

(4) A majority of the members of the Board shall constitute a quorum for the transaction of business, except that less than a quorum may adjourn meetings from time to time.

(d) Officers; Duties; Bonds.

(1) The officers of the Authority shall be the Chair, Vice Chair, Executive Director, Secretary and Treasurer. Such officers may be directors or officers of YVWD serving *ex officio*.

(2) The Chair of the Authority shall be the Board member who is the President of YVWD. The term of office of the Chair shall be the same as the term of the President of YVWD. The Chair shall preside at all meetings of the Authority, and shall submit such information and recommendations to the Board as he or she may consider proper concerning the business, policies and affairs of the Authority.

(3) The Vice Chair of the Authority shall be the Board member who is the Vice President of YVWD. The term of office of the Vice Chair shall be the same as the term of the Vice President of YVWD. The Vice Chair shall perform the duties of the Chair in the absence or incapacity of the Chair. In case of the resignation or death of the Chair, the Vice Chair shall perform such duties as are imposed on the Chair, until such time as a new Chair is selected or appointed.

(4) The General Manager of YVWD is hereby designated as the Executive Director of the Authority and shall be responsible for execution and supervision of the

affairs of the Authority. Except as otherwise authorized by resolution of the Board, the Executive Director or the Executive Director's designee shall sign all contracts, deeds and other instruments executed by the Authority. In addition, subject to the applicable provisions of any trust agreement, indenture or resolution providing for a trustee or other fiscal agent, the Executive Director is designated as the public officer or person who has charge of, handles or has access to any property of the Authority, and shall file an official bond if so required by the Board and, as such, shall have the powers, duties and responsibilities that are specified in Section 6505.1 of the Act.

(5) The Secretary of YVWD is hereby designated as the Secretary of the Authority. The Secretary shall keep the records of the Authority, shall act as Secretary at the meetings of the Authority and record all votes, and shall keep a record of the proceedings of the Authority in a journal of proceedings to be kept for such purpose, and shall perform all duties incident to the office. Any assistant secretary of YVWD shall also serve as an assistant secretary of the Authority and may take any actions for which the Secretary has become authorized by the Agreement, any Indenture, and any resolution of the Board of the Authority or otherwise.

(6) The Treasurer of YVWD is hereby designated as the Treasurer of the Authority. The Treasurer of the Authority is designated as the public officer or person who has charge of, handles, or has access to any property of the Authority, and such officer shall file an official bond as required by the Board, and as such shall have the power, duties and responsibilities that are specified in Section 6505.1 of the Act. The cost of the bond shall be paid by the Authority.

(7) So long as required by Sections 6505 and 6505.5 of the Act, the Treasurer of the Authority shall prepare or cause to be prepared: (a) a special audit as required pursuant to Section 6505 of the Act every year during the term of this Agreement; and (b) a report in writing on the first day of January, April, July and October of each year to the Board and the Members, which report shall describe the amount of money held by the Treasurer of the Authority for the Board, the amount of receipts since the last such report, and the amount paid out since the last such report (which may exclude amounts held by a trustee or other fiduciary in connection with any Bonds to the extent that such trustee or other fiduciary provides regular reports covering such amounts).

(8) The services of the officers shall be without compensation by the Authority. YVWD may provide such other administrative services as required by the Authority.

(9) The Board shall have the power to appoint such other officers and employees as it may deem necessary and to retain independent counsel, consultants and accountants.

(10) All of the privileges and immunities from liability, exemptions from laws, ordinances and rules, all pension, relief, disability, worker's compensation and other benefits which apply to the activities of officers, agents or employees of YVWD when performing their respective functions within the territorial limits of YVWD, shall apply to them to the same degree and extent while engaged in the performance of any of their functions and duties extraterritorially under the provisions of this Agreement.

(11) None of the officers, agents or employees, if any, directly employed by the Authority shall be deemed, by reason of their employment by the Authority, to be employed by YVWD or, by reason of their employment by the Authority, to be subject to any of the requirements or benefits of YVWD.

(12) The Members hereby confirm their intent and agree that, as provided in Section 4(a) hereof and in the Act, the debts, liabilities and obligations of the Authority shall not constitute debts, liabilities or obligations of the Members, and they do not intend by the following sentence to impair this provision. Notwithstanding Section 4(a) hereof, the confirmation provided immediately above, and the Act, YVWD shall indemnify, defend and hold harmless the Authority and the other Members and each of the Authority and the other Member's officers, directors, employees, attorneys and agents from and against any and all costs, expenses, losses, claims, damages, and liabilities directly or indirectly arising out of or in connection with the activities of the Authority. Each Member may elect to defend itself in any such action with counsel of its choice, the reasonable fees of such counsel to be paid by YVWD. Notwithstanding the provisions of Section 895.6 of the Government Code of the State, a Member shall not have any right to contribution from the Authority. This paragraph shall survive the termination of this Agreement.

(13) In any event, the Authority shall cause all records regarding the Authority's formation, existence, operations, any Bonds issued by the Authority, obligations incurred by it and proceedings pertaining to its termination to be retained for at least six (6) years following termination of the Authority or final payment of any Bonds issued by the Authority, whichever is later.

(14) Confirmation of officers shall be the first order of business at the first meeting of the Authority, regular or special, held in each calendar year.

(15) No Board member, officer, agent or employee of the Authority, without prior specific or general authority by a vote of the Board, shall have any power or authority to bind the Authority by any contract, to pledge its credit, or to render it liable for any purpose in any amount.

Section 5. Powers. The Authority shall have any and all powers which are common powers of the Members, and the powers separately conferred by law upon the Authority. All such powers, whether common to the Members or separately conferred by law upon the Authority, are specified as powers of the Authority, except any such powers which are specifically prohibited to the Authority by applicable law. The Authority's exercise of its powers is subject to the restrictions upon the manner of exercising the powers of YVWD.

The Authority is hereby authorized, in its own name, to do all acts necessary or convenient for the exercise of its powers, including, but not limited to, any or all of the following: to sue and be sued; to make and enter into contracts; to employ agents, consultants, attorneys, accountants, and employees; to acquire, hold or dispose of property, whether real or personal, tangible or intangible, wherever located; to issue Bonds or otherwise incur debts, liabilities or obligations to the extent authorized by the Act or any other applicable provision of law and to pledge any property or revenues or the rights thereto as security for such Bonds and other indebtedness.

Notwithstanding the foregoing, the Authority shall have any additional powers conferred under the Act or under applicable law, insofar as such additional powers may be necessary to accomplish the purposes set forth in Section 2 hereof.

This section shall be subject to the limitations on the powers of the Authority set forth in Section 4(a).

Section 6. Termination of Powers. The Authority shall continue to exercise the powers herein conferred upon it until the termination of this Agreement in accordance with Section 3 hereof.

Section 7. Fiscal Year. The first fiscal year of the Authority shall be the period from the date of this Agreement to last day of June 2022. Each subsequent fiscal year of the Authority shall be the period from July 1 of each year through the last day of June of the succeeding year, unless changed by resolution of the Board.

Section 8. Disposition of Assets. Upon termination of this Agreement pursuant to Section 3 hereof, any surplus money in possession of the Authority or on deposit in any fund or account of the Authority shall be returned in proportion to any contributions made as required by Section 6512 of the Act. The Board is vested with all powers of the Authority for the purpose of concluding and dissolving the business affairs of the Authority. After rescission or termination of this Agreement pursuant to Section 3 hereof, all property of the Authority, both real and personal, shall be distributed to YVWD.

Section 9. Contributions and Advances. Contributions or advances of public funds and of personnel, equipment or property may be made to the Authority by YVWD for any of the purposes of this Agreement. Payment of public funds may be made to defray the cost of any such contribution. Any such advance made in respect of a revenue-producing facility shall be made subject to repayment, and shall be repaid, in the manner agreed upon by YVWD, and the Authority at the time of making such advance as provided by Section 6512.1 of the Act. It is mutually understood and agreed that the Members have no obligation to make advances or contributions to the Authority to provide for the costs and expenses of administration of the Authority.

Section 10. Bonds.

(a) *Authority to Issue Bonds*. When authorized by the Act or other applicable provisions of law and by resolution of the Board, the Authority may issue Bonds for the purpose of raising funds for the exercise of any of its powers or to otherwise carry out its purposes under this Agreement. Said Bonds shall have such terms and conditions as are authorized by the Board.

(b) *Bonds Limited Obligations*. The Bonds, including the principal and any purchase price thereof, and the interest and premium, if any, thereon, shall be special obligations of the Authority payable solely from, and secured solely by, the revenues, funds and other assets that are pledged therefor under the applicable Indenture(s) and shall not constitute a charge against the general credit of the Authority or the Members. The Bonds shall not be secured by a legal or equitable pledge of, or lien or charge upon or security interest in, any property of the Authority or any Members (other than property of the Member executing a Security Agreement to secure such Bonds and only to the extent set forth in such Security Agreement) or any Authority income or receipts or any Members income or receipts (other than income or receipts of the Member executing a Security Agreement to secure such Bonds and only to the extent set forth in such Security Agreement) except the property, income and receipts pledged therefor under the applicable Indenture(s). The Bonds shall not constitute a debt, liability or obligation of the State or any public agency thereof, including any Member, other than the special obligation of the Authority as described above. Neither the faith and credit nor the taxing power of the State or any public agency thereof, including any Member, shall be pledged to the payment of the principal or purchase price of, or the premium, if any, or interest on the Bonds, nor shall the State or any public agency or

instrumentality thereof, including any Member, in any manner be obligated to make any appropriation for such payment. The Authority shall have no taxing power.

No covenant or agreement contained in any Bond or Indenture shall be deemed to be a covenant or agreement of any director, officer, agent or employee of the Authority, a Member or a Local Agency, in his or her individual capacity, and no director or officer of the Authority executing a Bond shall be liable personally on such Bond or be subject to any personal liability or accountability by reason of the issuance of such Bond.

Section 11. Agreement not Exclusive. This Agreement shall not be exclusive and shall not be deemed to amend or alter the terms of other agreements between the Members, except as the terms of this Agreement shall conflict therewith, in which case the terms of this Agreement shall prevail.

Section 12. Accounts and Reports. All funds of the Authority shall be strictly accounted for in books of account and financial records maintained by the Authority, including a report of all receipts and disbursements. The Authority shall establish and maintain such funds and accounts as may be required by generally accepted accounting principles and by each Indenture for outstanding Bonds (to the extent that such duties are not assigned to a trustee for owners of Bonds). The books and records of the Authority shall be open to inspection at all reasonable times by the Members and their representatives.

The Authority shall require that each Indenture provide that if a trustee is appointed thereunder, such trustee shall establish suitable funds, furnish financial reports and provide suitable accounting procedures to carry out the provisions of such Indenture. Said trustee may be given such duties in said Indenture as may be desirable to carry out the requirements of this Section 12.

(a) *Audits*. The Treasurer of the Authority shall cause an independent audit to be made of the books of accounts and financial records of the Authority in compliance with the requirements of the Act; provided, however, that if the Authority is deemed a component unit of the District, no independent audit of the Authority shall be required. Any costs of the audit, including contracts with, or employment of, certified public accountants or public accountants in making an audit pursuant to this Section 12, shall be borne by the Authority and shall be a charge against any unencumbered funds of the Authority available for that purpose.

(b) *Audit Reports*. The Treasurer of the Authority, as soon as practicable after the close of each fiscal year but in any event within the time necessary to comply with the requirements of the Act shall file a report of the audit performed pursuant to this Section 12(b) as required by the Act and shall send a copy of such report to public entities and persons in accordance with the requirements of the Act.

Section 13. Funds. Subject to the provisions of each Indenture for outstanding Bonds providing for a trustee to receive, have custody of and disburse funds which constitute Authority funds, the Treasurer of the Authority shall receive, have the custody of and disburse Authority funds pursuant to accounting procedures approved by the Board and shall make the disbursements required by this Agreement or otherwise necessary to carry out the provisions and purposes of this Agreement.

Section 14. Adoption of Certain Codes and Policies. The Authority shall, by resolution, adopt a Conflict of Interest Code, an investment policy and a debt management policy to the extent required by law. Such Conflict of Interest Code, investment policy and debt management policy may be the respective code or policies of YVWD.

Section 15. Notices. Notices and other communications hereunder to the parties shall be sufficient if delivered to the clerk or secretary of the governing body of each party.

Section 16. Withdrawal. No Member may withdraw from this Agreement prior to the end of the term of this Agreement determined in accordance with Section 3.

Section 17. Effectiveness. This Agreement shall become effective and be in full force and effect and a legal, valid and binding obligation of the Members when each party has executed a counterpart of this Agreement.

Section 18. Severability. Should any part, term, or provision of this Agreement be decided by the courts to be illegal or in conflict with any law of the State, or otherwise be rendered unenforceable or ineffectual, the validity of the remaining parts, terms or provisions hereof shall not be affected thereby.

Section 19. Successors; Assignment. This Agreement shall be binding upon and shall inure to the benefit of the successors of the parties hereto. Except to the extent expressly provided herein, neither party may assign any right or obligation hereunder without the consent of the other.

Section 20. Amendment of Agreement. This Agreement may be amended by supplemental agreement executed by the Members at any time; provided, however, that this Agreement may be terminated only in accordance with Section 3 hereof and, provided further, that such supplemental agreement shall be subject to any restrictions contained in any Bonds or documents related to any Bonds to which the Authority is a party.

Section 21. Waiver of Personal Liability. No Member, member of the Board, officer or employee of the Authority or the Members shall be individually or personally liable for any claims, losses, damages, costs, injury and liability of any kind, nature or description arising from the actions of the Authority or the actions undertaken pursuant to this Agreement, and the Authority shall defend such Members, members of the Board, officers or employees against any such claims, losses, damages, costs, injury and liability. Without limiting the generality of the foregoing, no Member, member of the Board, officer or employee of the Authority or of any Member shall be personally liable on any Bonds or be subject to any personal liability or accountability by reason of the issuance of Bonds pursuant to the Act and this Agreement. To the full extent permitted by law, the Board shall provide for indemnification by the Authority of any person who is or was a member of the Board, or an officer, employee or other agent of the Authority, and who was or is a party or is threatened to be made a party to a proceeding by reason of the fact that such person is or was such a member of the Board, or an officer, employee or other agent of the Authority, against expenses, judgments, fines, settlements and other amounts actually and reasonably incurred in connection with such proceeding, if such person acted in good faith and in the course and scope of his or her office, employment or agency. In the case of a criminal proceeding, the Board may provide for indemnification and defense of a member of the Board, or an officer, employee or other agent of the Authority to the extent permitted by law.

Section 22. Notices. Notices to a Member hereunder shall be sufficient if delivered to the General Manager of such Member.

Section 23. Section Headings. All section headings contained herein are for convenience of reference only and are not intended to define or limit the scope of any provision of this Agreement.

Section 24. Miscellaneous. This Agreement may be executed in several counterparts, each of which shall be an original and all of which shall constitute but one and the same instrument.

Where reference is made to duties to be performed for the Authority by a public official or employee, such duties may be performed by that person's duly authorized deputy or assistant. Where reference is made to actions to be taken by a Member, such action may be exercised through the officers, staff or employees of such Member in the manner provided by law.

The principal office of the Authority shall be the principal office of YVWD.

THIS AGREEMENT IS MADE IN THE STATE, UNDER THE CONSTITUTION AND LAWS OF THE STATE AND IS TO BE CONSTRUED AS A CONTRACT MADE AND TO BE PERFORMED IN THE STATE.

This Agreement is the complete and exclusive statement of the agreement among the parties with respect to the subject matter hereof, which supersedes and merges all prior proposals, understandings, and other agreements, whether oral, written, or implied in conduct, between the parties relating to the subject matter of this Agreement.

IN WITNESS WHEREOF, the parties hereto have caused this Agreement to be executed by their proper officers or officials thereunto duly authorized, as of the day and year first above written.

YUCAIPA VALLEY WATER DISTRICT

By _____
President

ATTEST:

Secretary

SAN BERNARDINO VALLEY MUNICIPAL
WATER DISTRICT

By: _____
President

ATTEST:

Secretary



Date: November 16, 2021

Task: N/A

Prepared By: Allison M. Edmisten, Chief Financial Officer

Subject: Presentation of the Unaudited Financial Report for the Period Ending on October 31, 2021

Recommendation: That the Board receive and file the unaudited financial report.

The following unaudited financial report has been prepared by the Administrative Department for your review. Please remember that the following financial information has not been audited.

Cash Fund Balance and Cash Flow Reports

The Cash Fund Balance Report provides a summary of how the total amount of funds maintained by financial institutions is distributed throughout the enterprise and non-enterprise funds of the District. A summary of the report is as follows:

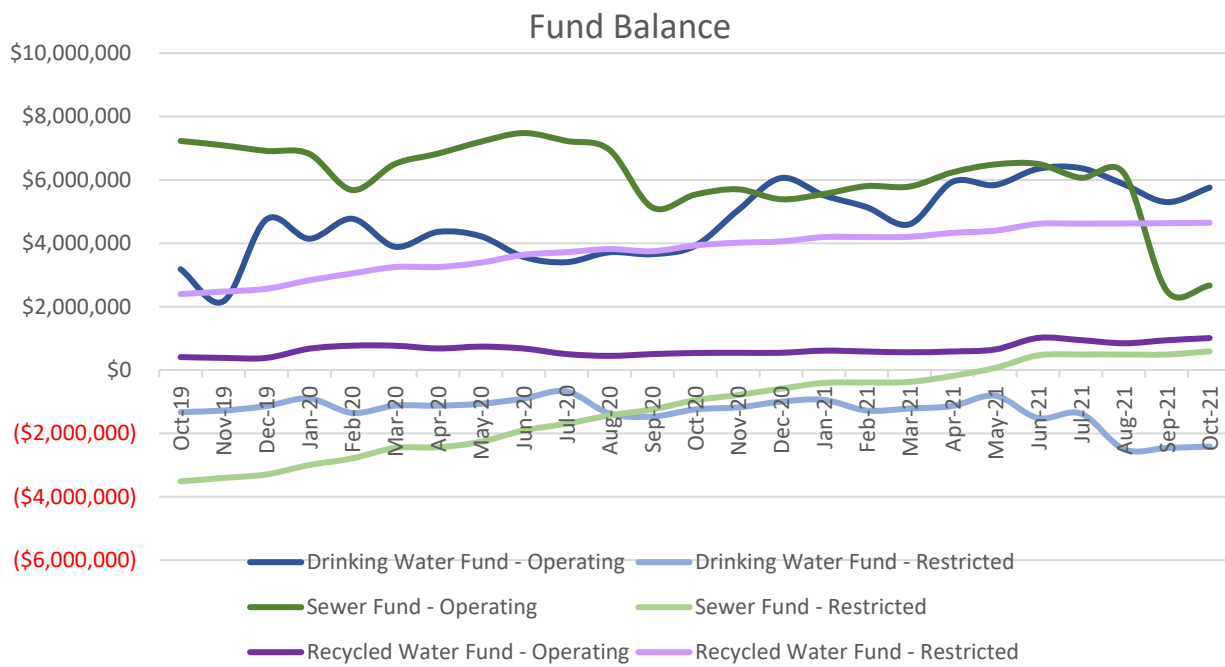

Most of the funds reflected in the Cash Fund Balance Report are designated for specific purposes and are therefore restricted, either by law or by District policy.

Cash Fund Balance Report - October 2021

Water Division		GL#	Balance
Restricted	ID 1 Construction Funds	02-000-10216	\$ 293,145.85
	ID 2 Construction Funds	02-000-10217	\$ -
	FCC - Debt Service YVRWFF Phase I	02-000-10401	\$ (7,761,977.82)
	FCC - Future YVRWFF Phase II & III	02-000-10403	\$ 720,612.50
	FCC - Recycled System	02-000-10410	\$ (400,074.62)
	FCC - Booster Pumping Plants	02-000-10411	\$ 1,099,955.64
	FCC - Pipeline Facilities	02-000-10412	\$ 1,454,692.17
	FCC - Water Storage Reservoirs	02-000-10413	\$ 1,733,504.01
	FCC - Excess Drinking Water	02-000-10414	\$ 443,063.69
Subtotal Restricted Funds			\$ (2,417,078.58)
Operating	Infrastructure Reserves	02-000-10311	\$ 3,300,742.80
	Sustainability Fund	02-000-10313	\$ 132,978.16
	Rate Stabilization Fund	02-000-10314	\$ 500,209.14
	Supplemental Water Fund - San Bernardino	02-000-10315	\$ 1,491,188.80
	Supplemental Water Fund - Riverside	02-000-10316	\$ 957,902.07
	Operating Funds:		\$ (626,652.07)
Subtotal Operating Funds			\$ 5,756,368.90
Total Water Division			\$ 3,339,290.32
Sewer Division		GL#	Balance
Restricted	SRF Reserve Fund - Brineline	03-000-10218	\$ 637,449.00
	SRF Reserve Fund - WISE	03-000-10219	\$ 184,928.00
	SRF Reserve Fund - R 10.3	03-000-10220	\$ 51,531.00
	SRF Reserve Fund - Crow St	03-000-10221	\$ 19,255.00
	FCC - Debt Service WWTP Expansion & Upgrade	03-000-10405	\$ 4,356,942.00
	FCC - Future WWTP Expansion	03-000-10407	\$ 3,174,421.91
	FCC - Sewer Interceptors	03-000-10415	\$ (442,788.39)
	FCC - Lift Stations	03-000-10416	\$ 519,320.23
	FCC - Effluent Disposal Facilities	03-000-10417	\$ (1,048,460.54)
	FCC - Salt Mitigation Facilities	03-000-10418	\$ (6,865,692.51)
Subtotal Restricted Funds			\$ 586,905.70
Operating	Project Fund - Encumbered	03-000-10215	\$ 1,400,805.00
	Infrastructure Reserves	03-000-10311	\$ 3,983,021.16
	Rate Stabilization Fund	03-000-10314	\$ 1,464,394.90
	Operating Funds:		\$ (4,182,490.43)
Subtotal Operating Funds			\$ 2,665,730.63
Total Wastewater Division			\$ 3,252,636.33
Recycled Water Division		GL#	Balance
Restricted	*FCC - Recycled System	04-000-10400	\$ 469.11
	FCC - Recycled System	04-000-10410	\$ 427,573.57
	FCC - Booster Pumping Plants	04-000-10411	\$ 294,247.95
	FCC - Pipeline Facilities	04-000-10412	\$ 2,095,779.80
	FCC - Water Storage Reservoirs	04-000-10413	\$ 1,760,209.11
	FCC - Excess Recycled Water	04-000-10414	\$ 69,585.27
	Subtotal Restricted Funds		
Oper	Infrastructure Reserves	04-000-10311	\$ 467,083.47
	Operating Funds:		\$ 538,949.38
Subtotal Operating Funds			\$ 1,006,032.85
Total Recycled Water Division			\$ 5,653,897.66
DISTRICT TOTAL			\$ 12,245,824.31

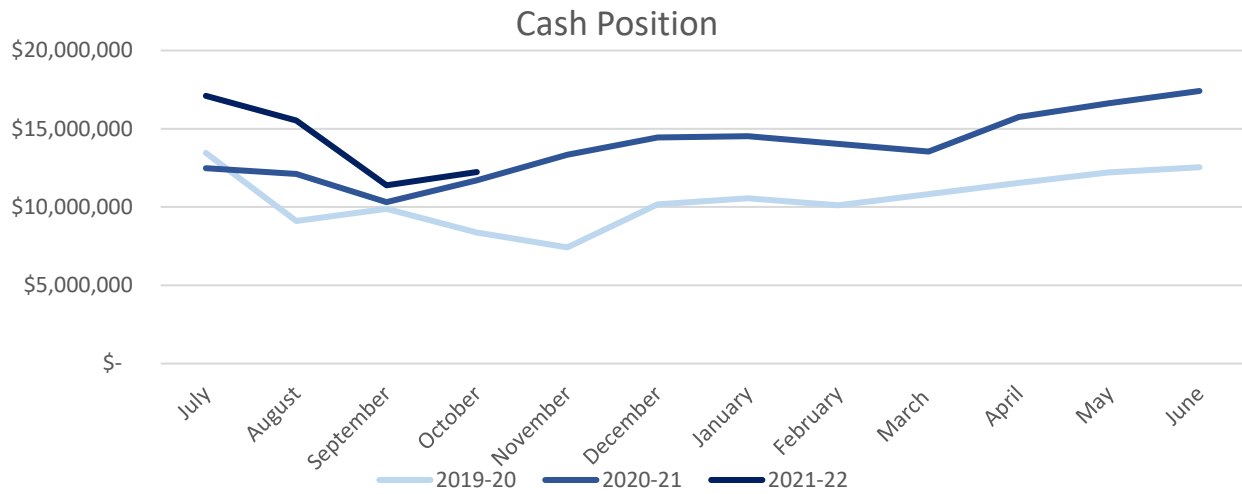

The Cash Flow Report provides a list of the debt service payment due dates and amounts as well as the cash flow requirements for debt service for each month of the fiscal year.

Cash Flow Report for Fiscal Year 2021-22

Financial Obligations for Fiscal Year 2021-22

Due Date	Fund	Description	Term of Obligation	Amount
9/1/2021	Water	2015A Bond Payment - YVRWFF	2015-2034	\$ 1,793,032.00
9/10/2021	Sewer	SRF Payment - WRWRF	2009-2028	\$ 2,923,668.75
12/31/2021	Sewer	SRF Payment - Yucaipa Regional Brineline	2013-2032	\$ 649,273.50
3/1/2022	Water	2015A Bond Payment - YVRWFF	2015-2034	\$ 503,032.00
3/31/2022	Sewer	SRF Payment - Recycled Reservoir R-10.3	2014-2033	\$ 54,277.31
3/31/2022	Sewer	SRF Payment - Desalinization at WRWRF	2014-2033	\$ 185,251.30
3/31/2022	Sewer	SRF Payment - Crow Street/Recycled Booster B-12.1	2016-2035	\$ 21,223.27
		Total		\$ 6,129,758.13

Payment Schedule and Cash Flow Requirements for Fiscal Year 2021-22

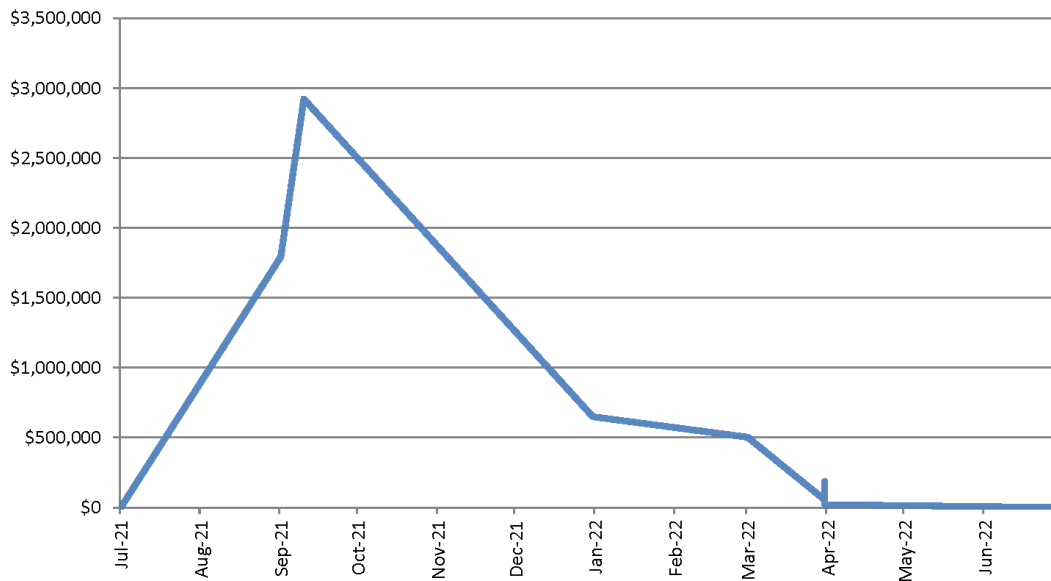

Cash Disbursement Report

The cash disbursement report lists each check and electronic payment processed during the month. All payments are reviewed by District staff for accuracy and completeness, checks are usually signed by the General Manager and one Director but may be signed by two Directors. The Chief Financial Officer will make any check, payment, invoice or supporting documentation available for review to any board member upon request.

Check Register - October 2021

Date	Check #	Payee or Description	Amount
10/4/2021	39966	ADS, LLC	\$ 6,210.00
10/4/2021	39967	Alpine Springs	\$ 92.45
10/4/2021	39968	Aramark Uniform and Career Apparel, LLC	\$ 843.45
10/4/2021	39969	AutoZone Stores LLC	\$ 32.61
10/4/2021	39970	Best Home Center	\$ 75.85
10/4/2021	39971	BofA Credit Card	\$ 2,738.29
10/4/2021	39972	Burgeson's Heating & Air Cond. Inc	\$ 980.00
10/4/2021	39973	California Water Environment Association	\$ 192.00
10/4/2021	39974	Center Electric Services, Inc.	\$ 1,935.00
10/4/2021	39975	Charles Wayne Hippenstiel	\$ 3,320.00
10/4/2021	39976	Coverall North America, Inc.	\$ 805.00
10/4/2021	39977	Crown Ace Hardware - Yucaipa	\$ 409.02
10/4/2021	39978	FMB Truck Outfitters, Inc.	\$ 142.87
10/4/2021	39979	G&G Environmental Compliance, Inc	\$ 3,069.70
10/4/2021	39980	Hemet Valley Tool Inc.	\$ 952.80
10/4/2021	39981	Houston & Harris PCS, Inc.	\$ 1,973.25
10/4/2021	39982	JW D'Angelo Co.	\$ 711.76
10/4/2021	39983	King Lee Chemical, Co.	\$ 16,930.87
10/4/2021	39984	Krieger & Stewart, Incorporated	\$ 112,668.70
10/4/2021	39985	LUZ Investment Corp.	\$ 750.00
10/4/2021	39986	Merit Oil Company	\$ 7,784.45
10/4/2021	39987	NetComp Technologies, Inc.	\$ 300.00
10/4/2021	39988	Ryan Herco Products Corp	\$ 268.82
10/4/2021	39989	San Bdn. Valley Muni. Water Dist.	\$ 37,918.60
10/4/2021	39990	SB CNTY-Treasurer-Tax	\$ 55.55
10/4/2021	39991	Superior Automotive Warehouse, Inc	\$ 14.18
10/4/2021	39992	The Dickson Company	\$ 1,896.53
10/4/2021	39993	The Gas Company	\$ 95.15
10/4/2021	39994	TPX Communications	\$ 2,238.72
10/4/2021	39995	Underground Service Alert Of So. CA	\$ 531.40
10/4/2021	39996	UPS Store#1504/ Mail Boxes Etc.	\$ 51.22
10/4/2021	39997	US Bank	\$ 18,977.24
10/4/2021	39998	Water Systems Optimization Inc.	\$ 2,500.00
10/4/2021	39999	Xpress Bill Pay	\$ 698.25
10/4/2021	40000	Yucaipa Disposal, Inc.	\$ 2,502.83

Check Register - October 2021

Date	Check #	Payee or Description	Amount
10/4/2021	40001	Yucaipa Valley Water District	\$ 69,401.54
10/4/2021	40002	Assoc. SB Cty Special Districts	\$ 30.00
10/8/2021	40003	California State Disbursement Unit	\$ 628.14
10/8/2021	40004	IBEW Local #1436	\$ 660.00
10/8/2021	40005	WageWorks Inc	\$ 1,686.89
10/11/2021	40006	California FAIR Plan	\$ 4,953.00
10/11/2021	40007	Aramark Uniform and Career Apparel, LLC	\$ 834.64
10/11/2021	40008	Bay Alarm Company	\$ 259.52
10/11/2021	40009	Brenntag Pacific, Inc	\$ 17,697.51
10/11/2021	40010	Burgeson's Heating & Air Cond. Inc	\$ 225.00
10/11/2021	40011	Caselle, Inc.	\$ 2,870.00
10/11/2021	40012	Center Electric Services, Inc.	\$ 1,311.00
10/11/2021	40013	City of Redlands	\$ 625.00
10/11/2021	40014	Clinical Laboratory of San Bernardino	\$ 40,492.50
10/11/2021	40015	Corelogic, Inc.	\$ 330.00
10/11/2021	40016	Coverall North America, Inc.	\$ 526.00
10/11/2021	40017	Crown Ace Hardware - Yucaipa	\$ 9.24
10/11/2021	40018	Dudek & Associates, Inc	\$ 750.00
10/11/2021	40019	Epic Pest Management	\$ 85.00
10/11/2021	40020	Freedom Mailing Services	\$ 8,510.57
10/11/2021	40021	Frontier Communications	\$ 170.65
10/11/2021	40022	Joe Zambetti	\$ 315.28
10/11/2021	40023	JW D'Angelo Co.	\$ 40,216.97
10/11/2021	40024	Konica Minolta Business Solutions	\$ 267.39
10/11/2021	40025	Les Schwab Tire Center	\$ 152.50
10/11/2021	40026	Q Versa, LLC	\$ 6,358.28
10/11/2021	40027	RAIN FOR RENT	\$ 4,871.56
10/11/2021	40028	REVIZE SOFTWARE SYSTEMS	\$ 1,800.00
10/11/2021	40029	San Bdno. Valley Muni. Water Dist.	\$ 37,146.29
10/11/2021	40030	SCHWING BIOSET, INC	\$ 750.24
10/11/2021	40031	Separation Processes, Inc.	\$ 13,084.22
10/11/2021	40032	South Coast A.Q.M.D.	\$ 14,011.36
10/11/2021	40033	Time Warner Cable	\$ 1,719.58
10/11/2021	40034	UPS Store#1504/ Mail Boxes Etc.	\$ 25.80
10/11/2021	40035	Watereuse Association	\$ 2,205.00
10/11/2021	40036	Clark Pest Control	\$ 118.00
10/11/2021	40037	Crown Ace Hardware - Yucaipa	\$ 267.90
10/11/2021	40038	DWS Advantage	\$ 2,278.14
10/11/2021	40039	Houston & Harris PCS, Inc.	\$ 1,973.25
10/11/2021	40040	Merit Oil Company	\$ 1,499.62
10/11/2021	40041	Nexa	\$ 675.00
10/11/2021	40042	Office Solutions Bsns Products, L	\$ 1,061.61
10/11/2021	40043	Pollardwater	\$ 287.66
10/11/2021	40044	Track Technologies	\$ 12,000.00
10/18/2021	40045	Delta Ventures Inc.	\$ 7,500.00

Check Register - October 2021

Date	Check #	Payee or Description	Amount
10/18/2021	40046	Dudek & Associates, Inc	\$ 3,076.25
10/18/2021	40047	Geoscience Support Services, Inc.	\$ 1,299.75
10/18/2021	40048	One Stop Landscape Supply Inc	\$ 20,802.50
10/18/2021	40049	Separation Processes, Inc.	\$ 8,738.37
10/18/2021	40050	Spiess Construction Company Inc	\$ 68,290.10
10/22/2021	40051	California State Disbursement Unit	\$ 628.14
10/22/2021	40052	WageWorks Inc	\$ 1,686.89
10/22/2021	40053	Alpine Springs	\$ 77.45
10/22/2021	40054	American Water Works Assoc.	\$ 302.00
10/22/2021	40055	Aqua-Metric Sales Company	\$ 59,582.67
10/22/2021	40056	Aramark Uniform and Career Apparel, LLC	\$ 840.79
10/22/2021	40057	AT&T Mobility	\$ 2,096.92
10/22/2021	40058	AutoZone Stores LLC	\$ 246.66
10/22/2021	40059	B.L. Wallace Distributor Inc.	\$ 1,110.17
10/22/2021	40060	Beaumont Basin Watermaster	\$ 1,340.00
10/22/2021	40061	BofA Credit Card	\$ 1,999.91
10/22/2021	40062	Brenntag Pacific, Inc	\$ 34,614.55
10/22/2021	40063	Contron Scada Systems	\$ 2,962.41
10/22/2021	40064	Crown Ace Hardware - Yucaipa	\$ 208.94
10/22/2021	40065	Davis Farr LLP	\$ 15,000.00
10/22/2021	40066	Doan and Hartwig Water Systems, Inc.	\$ 5,884.32
10/22/2021	40067	ECORP Consulting, Inc.	\$ 2,395.00
10/22/2021	40068	Evoqua Water Technologies LLC	\$ 2,449.53
10/22/2021	40069	Fastenal Company	\$ 1,685.61
10/22/2021	40070	G&G Environmental Compliance, Inc	\$ 3,834.44
10/22/2021	40071	Goldak Inc	\$ 164.09
10/22/2021	40072	Griswold Industries	\$ 5,061.77
10/22/2021	40073	Hasa, Inc.	\$ 8,234.26
10/22/2021	40074	Houston & Harris PCS, Inc.	\$ 1,973.25
10/22/2021	40075	Inland Kubota, Inc.	\$ 320.29
10/22/2021	40076	JW D'Angelo Co.	\$ 15,427.89
10/22/2021	40077	Les Schwab Tire Center	\$ 82.80
10/22/2021	40078	Lowe's Companies, Inc.	\$ 1,135.89
10/22/2021	40079	Merit Oil Company	\$ 7,228.83
10/22/2021	40080	NetComp Technologies, Inc.	\$ 600.00
10/22/2021	40081	Odyssey Power Corporation	\$ 2,775.00
10/22/2021	40082	Office Solutions Bsns Products, L	\$ 240.78
10/22/2021	40083	Patton Sales Corporation	\$ 3,002.02
10/22/2021	40084	POWERFLO PRODUCTS INC.	\$ 18,868.63
10/22/2021	40085	Pro-Pipe & Supply, Inc.	\$ 592.40
10/22/2021	40086	Quinn Company	\$ 56,287.64
10/22/2021	40087	SCE Rosemead	\$ 236,189.64
10/22/2021	40088	Spectrum Business	\$ 3,668.00
10/22/2021	40089	Summit Environmental Srvcs, Inc.	\$ 2,000.26

Check Register - October 2021

Date	Check #	Payee or Description	Amount
10/22/2021	40090	Superior Automotive Warehouse, Inc	\$ 191.09
10/22/2021	40091	The Counseling Team International	\$ 375.00
10/22/2021	40092	The Dickson Company	\$ 1,597.53
10/22/2021	40093	UGSI Chemical Feed, Inc.	\$ 3,788.53
10/22/2021	40094	US Bank	\$ 9,439.33
10/25/2021	40095	Atkinson, Andelson, Loya, Ruud & Romo	\$ 8,314.12
10/25/2021	40096	Cobb's Printing, LLC	\$ 161.63
10/25/2021	40097	Doug Earnest	\$ 685.14
10/25/2021	40098	Jesse McCartney	\$ 685.14
10/25/2021	40099	Joe DeSalliers	\$ 603.35
10/25/2021	40100	Peggy Little	\$ 685.14
10/25/2021	40101	Robert Wall	\$ 799.13
10/25/2021	40102	Taylor Corporation	\$ 96.26
10/25/2021	40103	WageWorks, Inc.	\$ 191.75
10/25/2021	40104	Aflac	\$ 2,576.53
10/25/2021	40105	Blue Shield of California	\$ 4,267.50
10/25/2021	40106	Nippon Life Insurance Co	\$ 2,711.77
10/25/2021	40107	Standard Dental Insurance Co	\$ 1,309.12
10/25/2021	40108	Standard Insurance Vision Plan	\$ 329.56
10/25/2021	40109	Western Dental Services Inc	\$ 154.98
10/25/2021	40110	All American Sewer Tools	\$ 1,759.15
10/25/2021	40111	Bay Alarm Company	\$ 374.52
10/25/2021	40112	Brenntag Pacific, Inc	\$ 6,715.05
10/25/2021	40113	BSK Associates	\$ 1,060.00
10/25/2021	40114	Burgeson's Heating & Air Cond. Inc	\$ 1,256.00
10/25/2021	40115	California Special Districts Association	\$ 8,195.00
10/25/2021	40116	California Water Environment Association	\$ 192.00
10/25/2021	40117	Crown Ace Hardware - Yucaipa	\$ 97.18
10/25/2021	40118	Doug's Filter Service, Inc.	\$ 400.00
10/25/2021	40119	Frontier Communications	\$ 46.25
10/25/2021	40120	Geoscience Support Services, Inc.	\$ 2,400.00
10/25/2021	40121	Grainger	\$ 552.66
10/25/2021	40122	Griswold Industries	\$ 14,031.58
10/25/2021	40123	Hasa, Inc.	\$ 3,628.79
10/25/2021	40124	Home Depot U.S.A. Inc	\$ 717.96
10/25/2021	40125	Houston & Harris PCS, Inc.	\$ 1,973.25
10/25/2021	40126	Jimmy Faucett	\$ 14.07
10/25/2021	40127	JW D'Angelo Co.	\$ 9,565.79
10/25/2021	40128	Kaseya US LLC	\$ 2,316.00
10/25/2021	40129	KnowBe4 Inc	\$ 5,795.28
10/25/2021	40130	Konica Minolta Business Solutions	\$ 279.66
10/25/2021	40131	Les Schwab Tire Center	\$ 82.80
10/25/2021	40132	McCall's Meter Sales & Service	\$ 1,303.43
10/25/2021	40133	Meritage Homes	\$ 67.34
10/25/2021	40134	Mission Communications, LLC	\$ 1,126.80

Check Register - October 2021

Date	Check #	Payee or Description	Amount
10/25/2021	40135	Mountain Gate LLC	\$ 21.13
10/25/2021	40136	Nearmap US Inc.	\$ 25,000.00
10/25/2021	40137	Pacwest Engineering Co., Inc.	\$ 42,522.00
10/25/2021	40138	Page Locksmith	\$ 66.09
10/25/2021	40139	Pro-Pipe & Supply, Inc.	\$ 1,280.50
10/25/2021	40140	Redline	\$ 21,381.18
10/25/2021	40141	Richmond American Homes	\$ 147.39
10/25/2021	40142	Riverside County Treasurer	\$ 197.62
10/25/2021	40143	SCE Rosemead	\$ 30.89
10/25/2021	40144	Southern CA Emergency Medicine, Inc.	\$ 75.00
10/25/2021	40145	Spectrum Business	\$ 2,649.00
10/25/2021	40146	State Water Resources Control Board	\$ 370.00
10/25/2021	40147	Stephanie Stachowski	\$ 15.08
10/25/2021	40148	TPX Communications	\$ 2,228.68
10/25/2021	40149	Track Technologies	\$ 8,000.00
			<u>\$ 1,345,212.94</u>
10/8/2021	electronic pmt	DIRECT DEPOSIT TOTAL	\$ 171,240.57
10/8/2021	electronic pmt	CalPERS 457 & Loan	\$ 27,903.92
10/8/2021	electronic pmt	CalPERS Retirement	\$ 33,793.83
10/8/2021	electronic pmt	EDD - State of California	\$ 14,296.32
10/8/2021	electronic pmt	IRS	\$ 73,290.40
10/8/2021	electronic pmt	VOYA 457 Retirement Plan	\$ 3,759.74
10/22/2021	electronic pmt	DIRECT DEPOSIT TOTAL	\$ 151,251.43
10/22/2021	electronic pmt	CalPERS 457 & Loan	\$ 24,905.23
10/22/2021	electronic pmt	CalPERS Retirement	\$ 32,853.75
10/22/2021	electronic pmt	EDD - State of California	\$ 12,252.26
10/22/2021	electronic pmt	IRS	\$ 63,078.16
10/22/2021	electronic pmt	VOYA 457 Retirement Plan	\$ 3,759.74
10/25/2021	electronic pmt	CalPERS Health Insurance	\$ 93,687.78
			<u>\$ 706,073.13</u>

Fiscal Year 2021-22 Reserve Transfers									
					Reserve Account - 10311				
Transfer Date	DM #	DM Date	Project	Description	Water	Sewer	Recycled	Transfer #	Resolution
7/29/2021	18-232	10/9/2018	1	AMI Project	\$ 24,453				
		8/3/2021	2	STIP		\$ 759,686		1	2021-44
9/30/2021	21-999	9/21/2021	3	Deionized Water System		\$ 9,707		2	2021-47
Total Transfers from Reserves					\$ (24,453)	\$ (769,393)	\$ -		
Beginning Balance @ 7/1/21					\$ 2,667,395	\$ 3,992,727	\$ 431,054		
Contribution to Reserves 2021-22					\$ 1,607,457	\$ -	\$ 74,755		
Ending Balance @ 6/30/22					\$ 4,250,399	\$ 3,223,334	\$ 505,809		

Summary of Projects		
Project	Description	Total Reserves Transfer
1	AMI Project	\$ 1,439,143
2	STIP	\$ 1,528,206
3	Deionized Water System	\$ 9,707

Began in 2019-21 (Project #3 in 2019-20 and #4 in 2020-21)
 Began in 2020-21 (Project #22 in prior year)

Financial Account Information

The District currently deposits all revenue received via mail or in person into the Deposit Checking account. All revenue received through Invoice Cloud is also deposited into the Deposit Checking account. The General Checking account is used as a sole processing account for all District checks and electronic payroll. The Investment Checking account is used for the purchase and redemption of US treasury notes and bills and for the transfer of LAIF funds. The US treasury notes and bills are booked at cost.

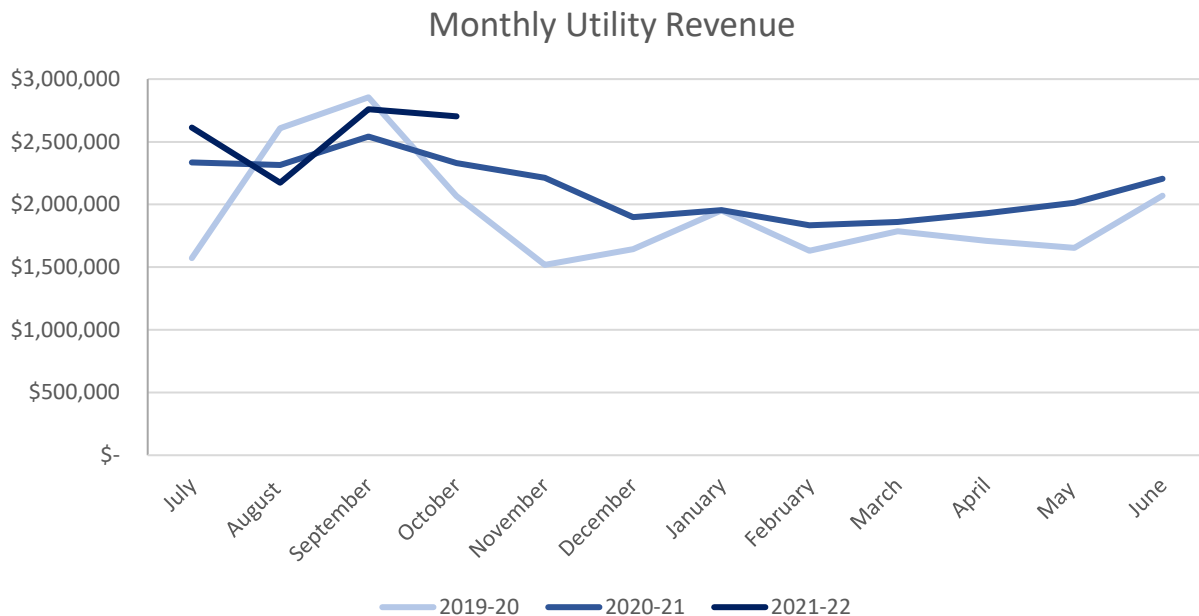

Invoice Cloud: Invoice Cloud is a third-party vendor the District utilizes to process credit card payments, echecks, online payments from customers, as well as phone payments processed without a live customer service representative.

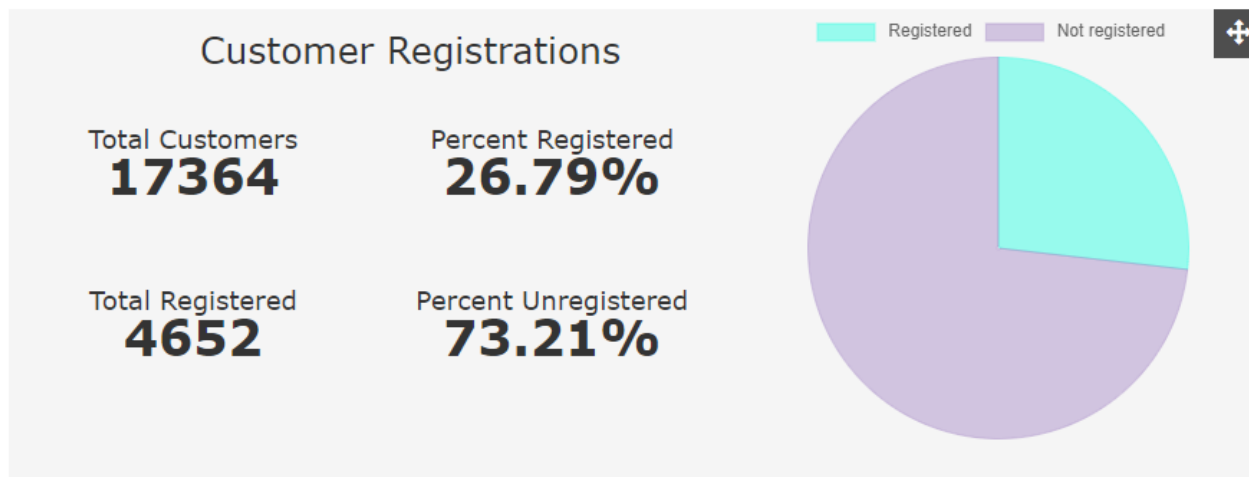

Compared to 3,994 last month (16% increase) and 7,278 customers enrolled on Xpress Bill Pay

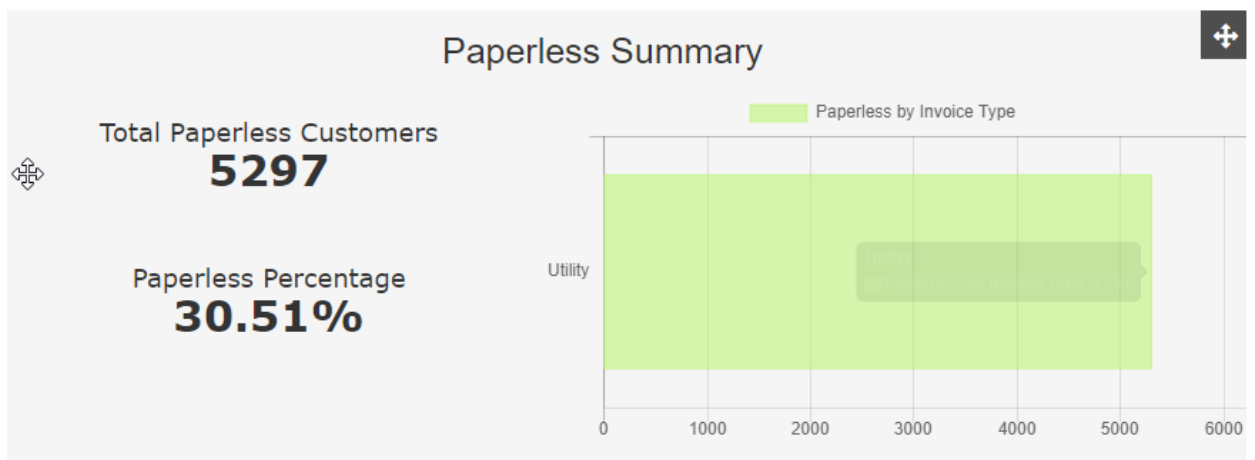
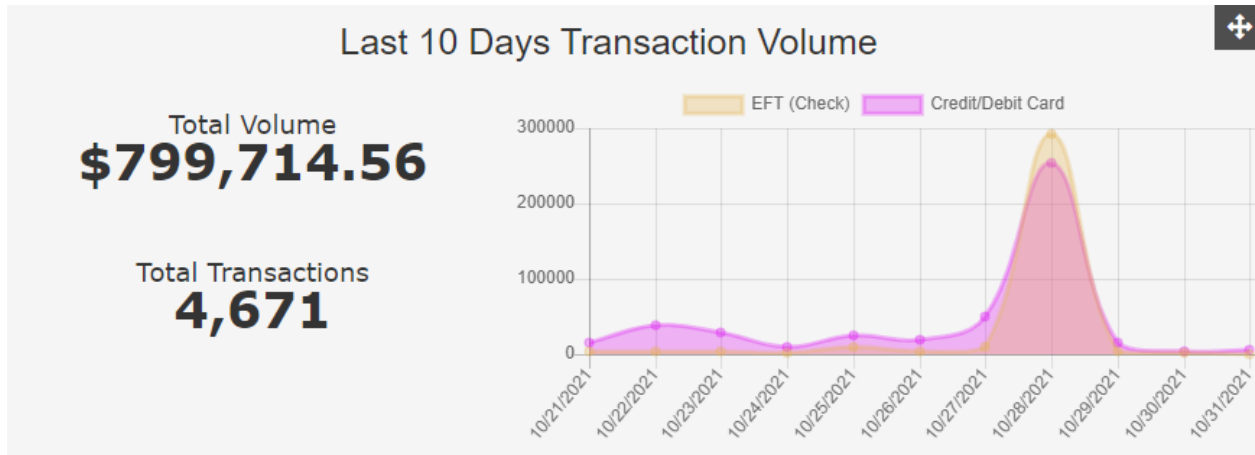

Compared to 4,607 last month (15% increase) and 2,455 on Xpress Bill Pay

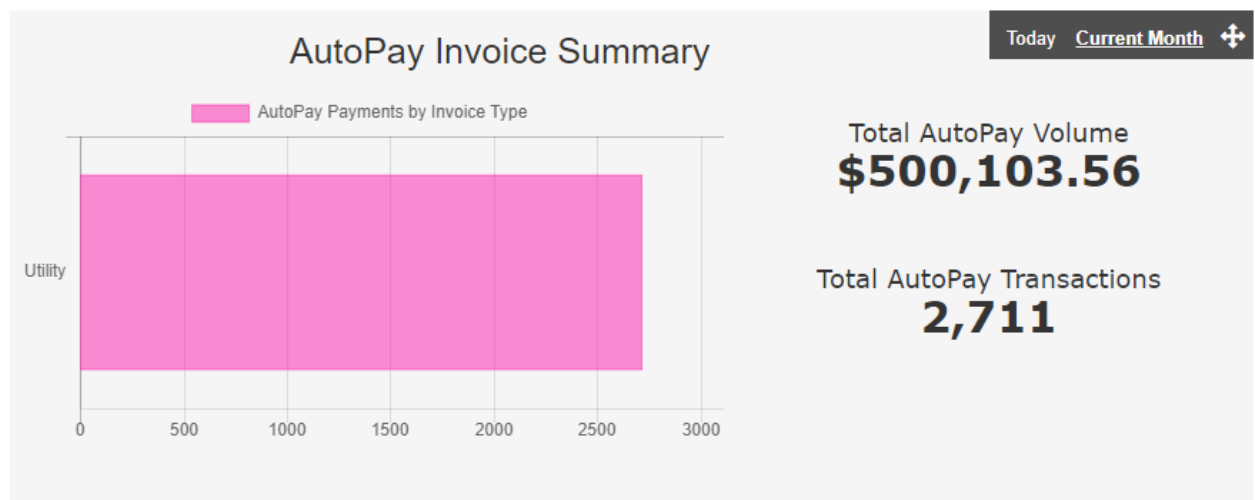

Compared to 1,962 last month (38% increase)

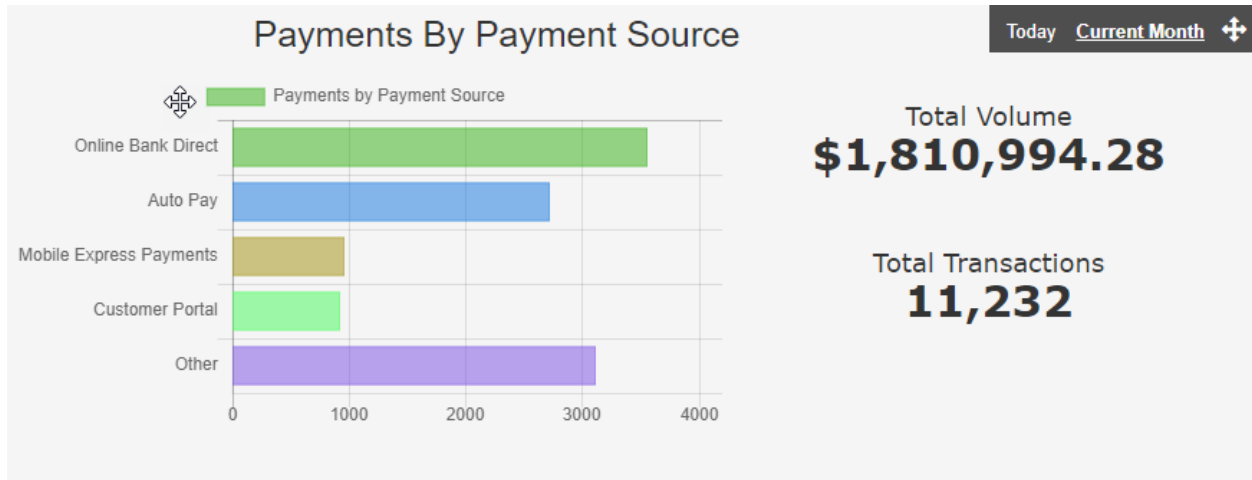

Compared to 11,056 transactions last month (1.6% increase)

We are continuing to work on building reports through Invoice Cloud for Auto Pay Customers as well as payments by payment source for the most recent month end.

Investment Summary

The investment summary report illustrates the District's investments in US treasury notes and bills in addition to the investments held by the Local Agency Investment Fund or LAIF. The yields for the treasury notes and bills are provided for each individual transaction. The historical annual yield for funds invested with LAIF is also provided.

Separate pooled money investment reports prepared by the State of California are maintained by the District and available for review. The LAIF investment account is a pooled money account administered by the State of California. Additional information on the LAIF account is provided below in the investment summary report.

Investment Policy Disclosure - The District is currently compliant with the portfolio of its Investment Policy and State law. The District is using Sandy Gage with Merrill Lynch Wealth Management (Bank of America Corporation) for Treasury investments. The District expects to meet its expenditure requirements for the next six months.

Summary of Property Tax Revenue:

Current Month	Year-to-Date	Budget Amount	Percentage
Property Taxes	\$ 0	\$ 3,718,826	0%

Property Taxes - Actual vs. Budget

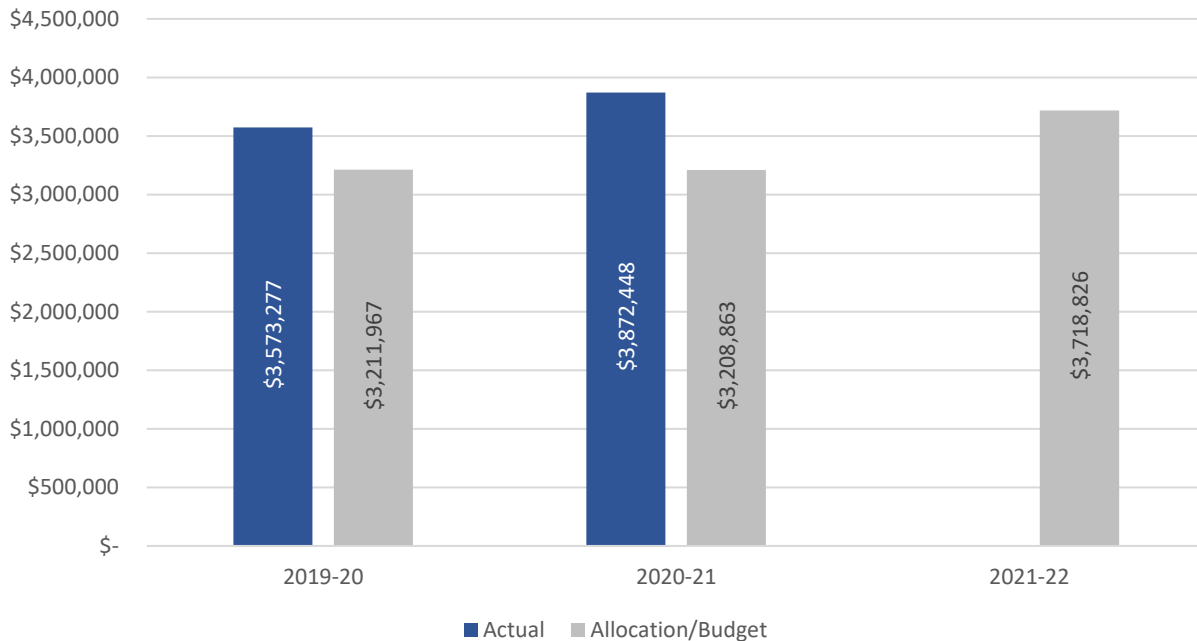

Management Discussion

This section is included in the monthly unaudited report to discuss items of importance that may have a financial impact on the District.

- The District continues to track the aging trends for Utility Receivables as a result of COVID-19 (see below).
- Late fees for past due balances will be reinstated after the first of the year.
- The annual financial audit is complete.
- The District is currently in the process of ordering the large meters that will be replaced as part of the \$75,000 grant that was received.
- The District received a \$75,000 grant for Basin Groundwater Monitoring Project
- District staff are currently working with Fieldman Rolapp on potential refinancing of debt.
- The Finance group has filled the two vacancies and the new employees start in November.

Average Pre-Covid	30 Days	60 Days	90 Days	120 Days
	\$281,219	\$41,173	\$20,379	\$27,505
7/31/2020	\$195,647	\$46,783	\$22,104	\$67,157
8/31/2020	\$272,158	\$62,221	\$28,082	\$74,515
9/30/2020	\$282,140	\$64,710	\$32,923	\$92,047
10/31/2020	\$254,095	\$79,254	\$40,271	\$112,550
11/30/2020	\$281,588	\$84,120	\$46,659	\$133,952
12/31/2020	\$251,518	\$77,823	\$53,354	\$157,520
1/31/2021	\$328,326	\$76,941	\$47,697	\$177,885
2/28/2021	\$273,713	\$76,804	\$42,494	\$198,653
3/31/2021	\$264,232	\$72,780	\$45,237	\$211,265
4/30/2021	\$236,321	\$111,345	\$45,143	\$226,894
5/31/2021	\$261,588	\$69,879	\$44,439	\$244,473
6/30/2021	\$231,995	\$80,694	\$43,964	\$262,736
7/31/2021	\$272,143	\$68,549	\$43,212	\$277,842
8/31/2021	\$255,242	\$82,352	\$45,061	\$275,665
9/30/2021	\$229,578	\$77,198	\$50,060	\$286,358
10/31/2021	\$192,632	\$75,430	\$42,047	\$313,402
Average Post Covid	\$264,156	\$74,271	\$36,975	\$143,544
% increase	-6.07%	80.39%	81.44%	421.88%

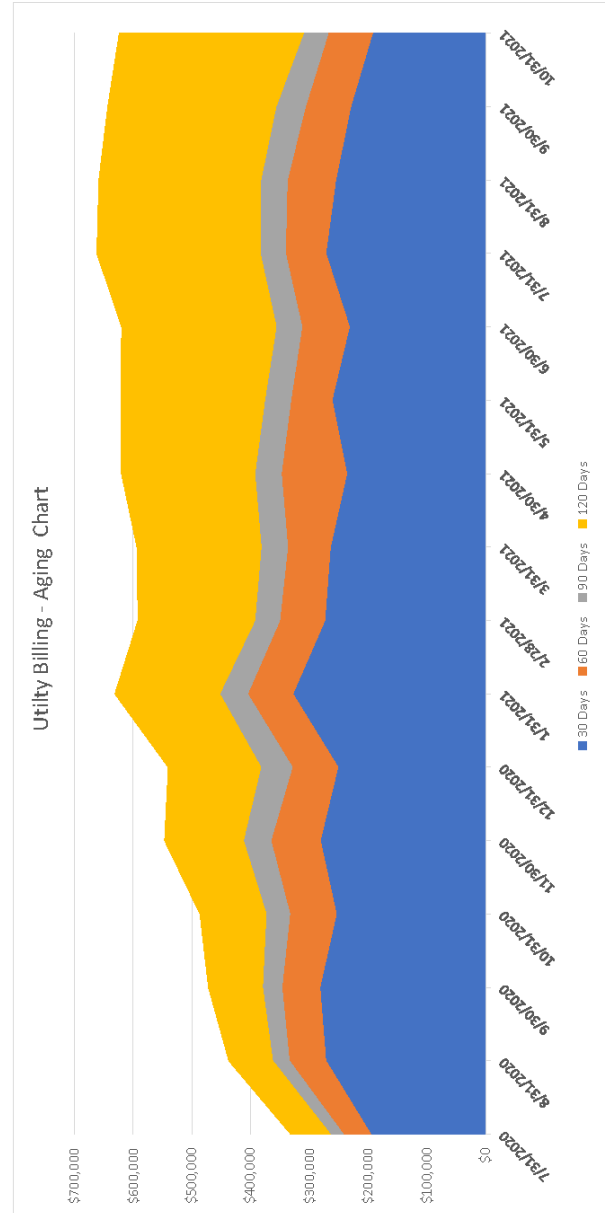
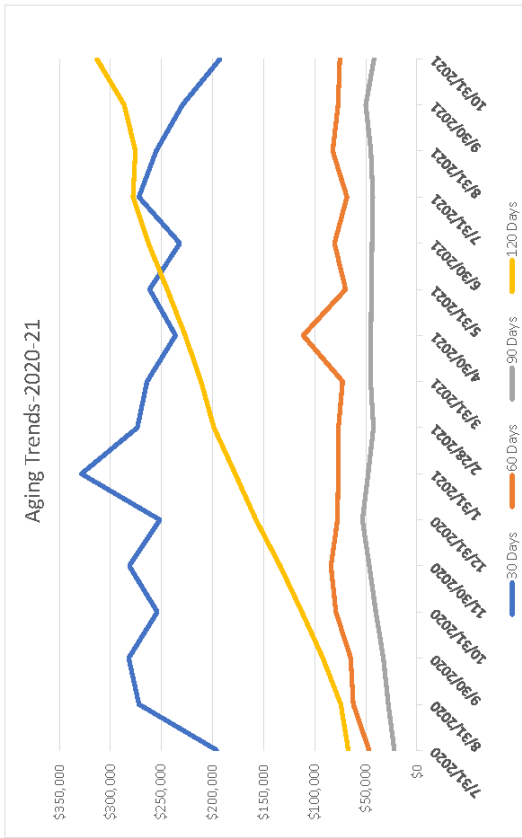

Investment Summary - October 2021

LOCAL AGENCY INVESTMENT FUND

PERIOD	TOTAL WITHDRAWAL AMOUNT	TOTAL DEPOSIT AMOUNT	ACCRUED INTEREST (QUARTERLY)	ENDING BALANCE
July 31, 2021	\$ -	\$ -	\$ 10,522.50	\$ 13,541,108.95
August 31, 2021	\$ (2,300,000.00)	\$ -	\$ -	\$ 11,241,108.95
September 30, 2021	\$ (1,000,000.00)	\$ -	\$ -	\$ 10,241,108.95
October 31, 2021	\$ -	\$ -	\$ 7,400.27	\$ 10,248,509.22
November 30, 2021	\$ -	\$ -	\$ -	\$ 10,248,509.22
December 31, 2021	\$ -	\$ -	\$ -	\$ 10,248,509.22
January 31, 2022	\$ -	\$ -	\$ -	\$ 10,248,509.22
February 28, 2022	\$ -	\$ -	\$ -	\$ 10,248,509.22
March 31, 2022	\$ -	\$ -	\$ -	\$ 10,248,509.22
April 30, 2022	\$ -	\$ -	\$ -	\$ 10,248,509.22
May 31, 2022	\$ -	\$ -	\$ -	\$ 10,248,509.22
June 30, 2022	\$ -	\$ -	\$ -	\$ 10,248,509.22

L.A.I.F. INCOME SUMMARY

CURRENT QUARTER FY YEAR-TO-DATE

INCOME RECEIVED

\$ 7,400.27 \$ 17,922.77

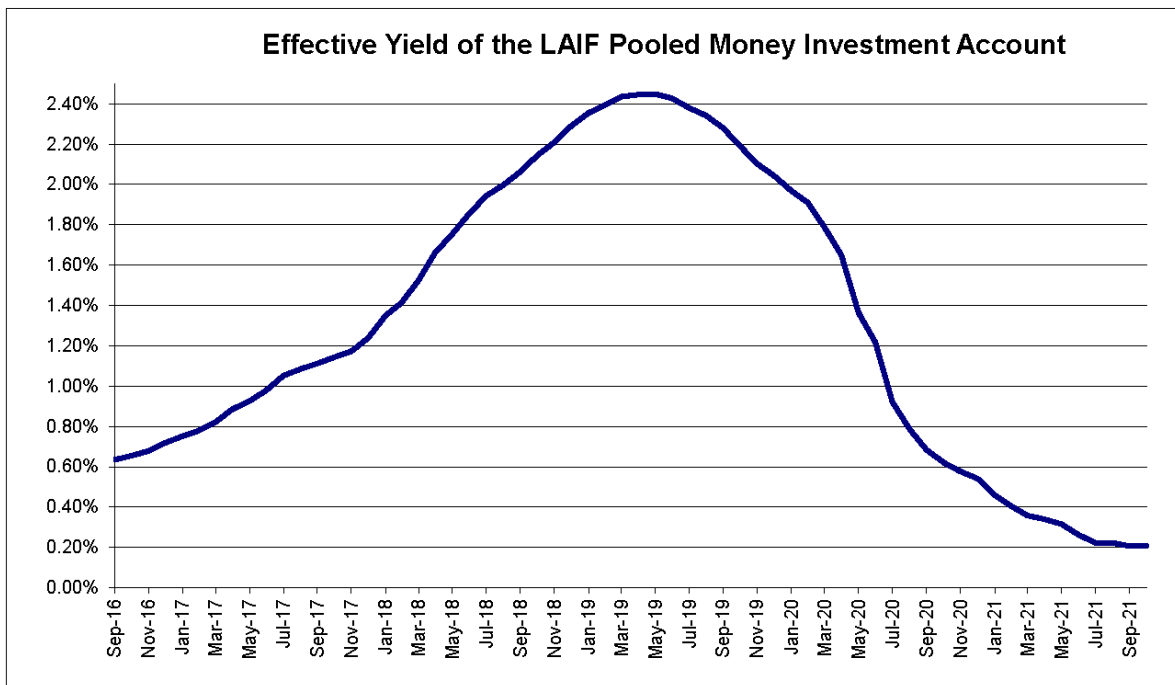

Fiscal Year 2021-22 Detail Budget Status

The revenue and expense budget status for the 2021-22 Fiscal Year is provided for your review.

Questions or Comments

If you have any questions about a particular budget account, please do not hesitate to contact the Chief Financial Officer directly. If you need additional information, the members of the Administrative Department would be happy to provide you with any detailed information you may desire.

Summary of Revenue Budget				
As of October 31, 2021 (33% of Budget Cycle)				
Division	Current Month	Year-to-Date	Budget Amount	Percentage
Water	\$ 993,397	\$ 5,237,251	\$ 17,274,066	30.32%
Sewer	\$ 1,048,283	\$ 4,216,891	\$ 13,136,249	32.10%
Recycled Water	\$ 139,632	\$ 666,669	\$ 1,357,175	49.12%
District Revenue	\$ 2,181,312	\$ 10,120,811	\$ 31,767,490	31.86%

Summary of Water Budget vs. Expenses				
As of October 31, 2021 (33% of Budget Cycle)				
Department	Current Month	Year-to-Date	Budget Amount	Percentage
Water Resources	\$ 370,485	\$ 1,638,566	\$ 5,500,564	29.79%
Public Works	\$ 142,847	\$ 895,813	\$ 3,334,949	26.86%
Administration	\$ 159,380	\$ 986,451	\$ 2,736,004	36.05%
Long Term Debt	\$ -	\$ 1,805,931	\$ 2,296,063	78.65%
Asset Acquisition	\$ -	\$ -	\$ 3,406,486	0.00%
TOTAL	\$ 672,712	\$ 5,326,761	\$ 17,274,066	30.84%

Summary of Sewer Budget vs. Expenses				
As of October 31, 2021 (33% of Budget Cycle)				
Department	Current Month	Year-to-Date	Budget Amount	Percentage
Treatment	\$ 236,314	\$ 1,265,916	\$ 4,643,308	27.26%
Administration	\$ 142,948	\$ 1,219,291	\$ 2,579,815	47.26%
Environmental Control	\$ 96,062	\$ 432,109	\$ 1,394,057	31.00%
Long Term Debt	\$ 2,923,669	\$ 2,923,669	\$ 3,998,869	73.11%
Asset Acquisition	\$ -	\$ -	\$ 520,200	0.00%
TOTAL	\$ 3,398,992	\$ 5,840,984	\$ 13,136,249	44.46%

Summary of Recycled Water Budget vs. Expenses				
As of October 31, 2021 (33% of Budget Cycle)				
Department	Current Month	Year-to-Date	Budget Amount	Percentage
Administration	\$ 100,095	\$ 400,156	\$ 1,357,175	29.48%
TOTAL	\$ 100,095	\$ 400,156	\$ 1,357,175	29.48%
District Expenses	\$ 4,171,798	\$ 11,567,902	\$ 31,767,490	36.41%

FY 2021-22 Water Revenue					
G/L ACCOUNT#	DESCRIPTION	BUDGET	Oct '21	Year to Date	%
02-400-40010	Sales-Water & Non Potable	\$ 5,940,677	\$ 513,482	\$ 3,030,388	51.01%
02-400-40011	Sales-Construction Water	\$ 104,040	\$ 1,554	\$ 16,106	15.48%
02-400-40012	Sales-Imported Water-SGPWA	\$ 265,225	\$ 21,625	\$ 127,376	48.03%
02-400-40013	Sales-Imported Water-MUNI	\$ 901,765	\$ 62,674	\$ 354,364	39.30%
02-400-40014	Sales-Disc (Multi Unit) Commdy	\$ (110,000)	\$ (8,799)	\$ (44,720)	40.65%
02-400-40015	Sales-Wholesale Water	\$ 212,180	\$ 17,550	\$ 75,783	35.72%
02-400-40016	Sales-Establish Service Fee	\$ 6,242	\$ 350	\$ 450	7.21%
02-400-40017	Sales-Excess Drinking Water	\$ 587,062	\$ 15,119	\$ 131,741	22.44%
02-400-40018	Sales-Infrastructure	\$ 1,399,377	\$ 127,158	\$ 715,599	51.14%
02-400-41000	Sales-Service Demand Charges	\$ 4,017,585	\$ 336,413	\$ 1,344,006	33.45%
02-400-41001	Sales-Fire Srv Standby Fees	\$ 41,616	\$ 5,411	\$ 21,653	52.03%
02-400-41003	Sales-Const Water Minimum Chg	\$ 5,202	\$ 267	\$ 1,090	20.95%
02-400-41005	Sales-Disc (Multi Units)-SC	\$ (121,838)	\$ (12,556)	\$ (49,916)	40.97%
02-400-41010	Unauthorized Use of Water Chrg	\$ 2,081	\$ -	\$ 500	24.03%
02-400-41110	Meter/Lateral Installation	\$ 104,040	\$ 3,667	\$ 6,460	6.21%
02-400-41112	Fire Flow Test Fees	\$ 4,682	\$ 300	\$ 2,100	44.85%
02-400-41113	Disconnect & Reconnect Fees	\$ 106,090	\$ -	\$ -	0.00%
02-400-41121	Delinquent Payment Charges	\$ 143,222	\$ -	\$ -	0.00%
02-400-41124	Bad Debt Write-Off & Recovery	\$ (20,808)	\$ -	\$ -	0.00%
02-421-42122	Revenue - Other, Operating	\$ -	\$ 73	\$ 218	N/A
02-421-42123	Admin, Management & Acctg Fees	\$ 210,681	\$ 17,557	\$ 70,227	33.33%
02-430-43010	Interest Earned	\$ 25,000	\$ 3,330	\$ 3,330	13.32%
02-431-43110	Property Tax - Unsecured	\$ -	\$ -	\$ -	N/A
02-431-43120	Property Tax - Secured	\$ 3,346,943	\$ -	\$ -	0.00%
02-431-43130	Tax Collection - Prior	\$ -	\$ 3,390	\$ 3,390	N/A
02-431-43140	Taxes - Other	\$ -	\$ (8)	\$ (8)	N/A
02-491-49110	Rental Income	\$ 3,001	\$ -	\$ -	0.00%
02-491-49150	Revenue - Misc Non-Operating	\$ 25,001	\$ (115,160)	\$ (572,884)	-2291.44%
	WATER OPERATING REVENUE	\$ 17,199,066	\$ 993,397	\$ 5,237,251	30.45%
	Transfer - Reserve Fund	\$ -	\$ -	\$ -	
02-480-48002	Grants	\$ 75,000	\$ -	\$ -	0.00%
02-480-48901	Contrib Cap-Capacity Fees	\$ -	\$ 46,230	\$ 165,519	N/A
02-480-48902	Contrib Cap-Sustainability	\$ -	\$ 3,522	\$ 4,403	N/A
	TOTAL WATER REVENUE	\$ 17,274,066	\$ 1,043,149	\$ 5,407,172	31.30%

NOTE: Plan check & inspection fees to 02-42122

FY 2021-22 Sewer Revenue					
G/L ACCOUNT#	DESCRIPTION	BUDGET	Oct '21	Year to Date	%
03-400-40016	Sales-Establish Service Fee	\$ 520	\$ -	\$ -	0.00%
03-400-41000	Sales-Sewer Charges	\$ 12,750,661	\$ 1,060,612	\$ 4,267,400	33.47%
03-400-41005	Sales-Disc (Multi Units)-SC	\$ (200,000)	\$ (17,639)	\$ (70,250)	35.12%
03-400-41110	Meter/Lateral Installation	\$ 15,075	\$ -	\$ 2,500	16.58%
03-400-41121	Penalty - Late Charges	\$ 127,513	\$ -	\$ -	0.00%
03-400-41124	Bad Debt Write-Off & Recovery	\$ (15,150)	\$ -	\$ -	0.00%
03-400-41131	Front Footage Fees	\$ 56,106	\$ -	\$ 11,750	20.94%
03-421-42122	Revenue - Other, Operating	\$ 2,040	\$ 1,980	\$ 2,160	105.88%
03-430-43010	Interest Eamed	\$ 25,000	\$ 3,330	\$ 3,330	13.32%
03-431-43110	Property Tax - Unsecured	\$ -	\$ -	\$ -	N/A
03-431-43120	Property Tax - Secured	\$ 371,883	\$ -	\$ -	0.00%
03-431-43130	Tax Collection - Prior	\$ -	\$ -	\$ -	N/A
03-431-43140	Taxes - Other	\$ -	\$ -	\$ -	N/A
03-491-49150	Revenue - Misc Non-Operating	\$ 2,601	\$ -	\$ -	0.00%
	SEWER OPERATING REVENUE	\$ 13,136,249	\$ 1,048,283	\$ 4,216,891	32.10%
03-480-48002	Grants	\$ -	\$ -	\$ -	N/A
03-480-48901	Contrib Cap-Capacity Fees	\$ -	\$ 98,652	\$ 126,603	N/A
03-480-48905	Contrib Cap-Infrastructure	\$ -	\$ -	\$ 3,600	N/A
	TOTAL SEWER REVENUE	\$ 13,136,249	\$ 1,146,935	\$ 4,347,094	33.09%

FY 2021-22 Recycled Revenue					
G/L ACCOUNT#	DESCRIPTION	BUDGET	Oct '21	Year to Date	%
04-400-40010	Sales-Water & Non Potable	\$ 1,000,000	\$ 107,617	\$ 521,398	52.14%
04-400-40011	Sales-Construction Water	\$ 10,180	\$ -	\$ -	0.00%
04-400-40017	Sales-Excess Drinking Water	\$ 25,000	\$ 3,765	\$ 25,554	102.22%
04-400-40018	Sales-Infrastructure	\$ 74,755	\$ 7,802	\$ 43,832	58.63%
04-400-41000	Sales-Service Demand Charges	\$ 188,897	\$ 18,313	\$ 72,940	38.61%
04-400-41003	Sales-Const Water Minimum Chg	\$ 823	\$ 201	\$ 720	87.48%
04-400-41110	Meter/Lateral Installation	\$ 50,000	\$ 1,122	\$ 1,122	2.24%
04-400-41121	Penalty - Late Charges	\$ 2,010	\$ -	\$ -	0.00%
04-400-41122	Revenue - Other, Operating	\$ 510	\$ 73	\$ 364	71.29%
04-430-43010	Interest Earned	\$ 5,000	\$ 740	\$ 740	14.80%
04-431-43110	Property Tax - Unsecured	\$ -	\$ -	\$ -	N/A
04-431-43120	Property Tax - Secured	\$ -	\$ -	\$ -	N/A
04-431-43130	Tax Collection - Prior	\$ -	\$ -	\$ -	N/A
04-431-43140	Taxes - Other	\$ -	\$ -	\$ -	N/A
04-491-49150	Revenue-Misc Non-Operating	\$ -	\$ -	\$ -	N/A
	RECYCLED OPERATING REVENUE	\$ 1,357,175	\$ 139,632	\$ 666,669	49.12%
04-480-48002	Grants	\$ -	\$ -	\$ -	N/A
04-480-48901	Contrib Cap-Capacity Fees	\$ -	\$ 15,177	\$ 15,177	N/A
	TOTAL RECYCLED REVENUE	\$ 1,357,175	\$ 154,810	\$ 681,847	50.24%

FY 2021-22 Water Expenses					
G/L ACCOUNT #	DESCRIPTION	BUDGET	Oct '21	Year to Date	%
02-501-50009	Labor - Overtime	\$ 49,944	\$ 4,238	\$ 17,077	34.19%
02-501-50010	Labor	\$ 1,046,041	\$ 93,648	\$ 347,626	33.23%
02-501-50011	Labor - Credit	\$ -	\$ -	\$ -	N/A
02-501-50013	Benefits-FICA	\$ 100,270	\$ 7,970	\$ 29,852	29.77%
02-501-50014	Benefits-Life Insurance	\$ 3,863	\$ 123	\$ 529	13.69%
02-501-50016	Benefits-Health & Def Comp	\$ 212,989	\$ 18,386	\$ 79,193	37.18%
02-501-50017	Benefits-Disability Insurance	\$ 23,332	\$ 1,240	\$ 5,282	22.64%
02-501-50019	Benefits-Workers Compensation	\$ 69,237	\$ -	\$ 3,815	5.51%
02-501-50021	Benefits-PERS Employee	\$ -	\$ -	\$ -	N/A
02-501-50022	Benefits-PERS Employer	\$ 77,054	\$ 5,246	\$ 22,407	29.08%
02-501-50023	Benefits-Uniforms	\$ 5,346	\$ 72	\$ 489	9.15%
02-501-50024	Benefits-Vacation & Sick Pay	\$ -	\$ -	\$ -	N/A
02-501-50025	Benefits-Boots & Incentives	\$ 8,700	\$ -	\$ -	0.00%
02-501-51003	R&M - Structures	\$ 312,120	\$ 105	\$ 27,660	8.86%
02-501-51011	R&M - Valves	\$ 20,808	\$ 5,695	\$ 18,600	89.39%
02-501-51115	Laboratory Supplies	\$ 2,601	\$ -	\$ -	0.00%
02-501-51140	General Supplies & Expenses	\$ 16,000	\$ 3,982	\$ 7,824	48.90%
02-501-51210	Power Purchases	\$ 1,750,000	\$ 204,755	\$ 688,101	39.32%
02-501-51211	Electricity & Fuel	\$ 5,202	\$ 331	\$ 1,120	21.52%
02-501-51316	Supplemental Source of Supply	\$ 1,096,608	\$ -	\$ 226,239	20.63%
02-501-54012	Education & Training	\$ 7,303	\$ -	\$ -	0.00%
02-501-54019	Licenses & Permits	\$ 67,626	\$ 1,227	\$ 1,227	1.81%
02-501-54025	Telephone & Internet	\$ 3,300	\$ 284	\$ 872	26.42%
02-501-54110	Laboratory Services	\$ 50,000	\$ 200	\$ 12,602	25.20%
02-501-57040	YVRWFF-Crystal Creek Exp	\$ 572,220	\$ 22,983	\$ 148,051	25.87%
	WATER RESOURCE TOTALS	\$ 5,500,564	\$ 370,485	\$ 1,638,566	29.79%
02-503-50009	Labor - Overtime	\$ 64,914	\$ 3,276	\$ 19,598	30.19%
02-503-50010	Labor	\$ 1,651,642	\$ 108,283	\$ 462,536	28.00%
02-503-50011	Labor - Credit	\$ -	\$ (433)	\$ (2,214)	N/A
02-503-50013	Benefits-FICA	\$ 166,099	\$ 9,013	\$ 38,841	23.38%
02-503-50014	Benefits-Life Insurance	\$ 7,773	\$ 258	\$ 1,052	13.53%
02-503-50016	Benefits-Health & Def Comp	\$ 451,925	\$ 38,344	\$ 155,147	34.33%
02-503-50017	Benefits-Disability Insurance	\$ 38,646	\$ 1,780	\$ 7,382	19.10%
02-503-50019	Benefits-Workers Compensation	\$ 12,551	\$ -	\$ 3,815	30.40%
02-503-50021	Benefits-PERS Employee	\$ -	\$ -	\$ -	N/A
02-503-50022	Benefits-PERS Employer	\$ 123,505	\$ 7,890	\$ 32,538	26.35%
02-503-50023	Benefits-Uniforms	\$ 12,012	\$ 122	\$ 1,747	14.54%
02-503-50024	Benefits-Vacation & Sick Pay	\$ -	\$ -	\$ -	N/A
02-503-50025	Benefits-Boots & Incentives	\$ 18,503	\$ -	\$ -	0.00%
02-503-51001	R&M - Vehicles & Equipment	\$ 275,000	\$ 2,863	\$ 76,151	27.69%
02-503-51011	R&M - Valves	\$ 5,202	\$ 15,724	\$ 15,724	302.27%
02-503-51020	R&M - Pipelines	\$ 208,080	\$ 10,562	\$ 27,600	13.26%

FY 2021-22 Water Expenses						
G/L ACCOUNT #	DESCRIPTION	BUDGET	Oct '21	Year to Date	%	
02-503-51021	R&M - Service Lines	\$ 99,878	\$ 13,200	\$ 29,906	29.94%	
02-503-51022	R&M - Fire Hydrants	\$ 52,020	\$ 887	\$ 7,042	13.54%	
02-503-51029	Repair & Maintenance-Backflow	\$ 67,626	\$ 679	\$ 13,474	19.92%	
02-503-51030	R&M - Meters	\$ 31,212	\$ (69,729)	\$ 3,747	12.00%	
02-503-51031	R&M - Fire Flow Testing	\$ 26,010	\$ -	\$ 1,179	4.53%	
02-503-51092	Equipment Credits	\$ -	\$ (266)	\$ (2,559)	N/A	
02-503-51140	General Supplies & Expenses	\$ 3,121	\$ -	\$ 283	9.07%	
02-503-54012	Education & Training	\$ 15,230	\$ -	\$ 1,650	10.83%	
02-503-54025	Telephone & Internet	\$ 4,000	\$ 392	\$ 1,176	29.40%	
	PUBLIC WORKS TOTALS	\$ 3,334,949	\$ 142,847	\$ 895,813	26.86%	
02-506-50009	Labor - Overtime	\$ 5,736	\$ 1,779	\$ 4,432	77.27%	
02-506-50010	Labor	\$ 601,289	\$ 47,180	\$ 189,303	31.48%	
02-506-50011	Labor - Credit	\$ -	\$ -	\$ 3,290	N/A	
02-506-50012	Director Fees	\$ 20,000	\$ 2,522	\$ 7,646	38.23%	
02-506-50013	Benefits-FICA	\$ 60,066	\$ 3,904	\$ 15,355	25.56%	
02-506-50014	Benefits-Life Insurance	\$ 2,839	\$ 67	\$ 311	10.95%	
02-506-50016	Benefits-Health & Def Comp	\$ 156,292	\$ 15,155	\$ 61,651	39.45%	
02-506-50017	Benefits-Disability Insurance	\$ 13,978	\$ 627	\$ 2,601	18.61%	
02-506-50019	Benefits-Workers Compensation	\$ 3,653	\$ -	\$ 1,800	49.27%	
02-506-50021	Benefits-PERS Employee	\$ -	\$ -	\$ -	N/A	
02-506-50022	Benefits-PERS Employer	\$ 49,910	\$ 3,676	\$ 15,481	31.02%	
02-506-50023	Benefits-Uniforms	\$ -	\$ 178	\$ 696	N/A	
02-506-50024	Benefits-Vacation & Sick Pay	\$ -	\$ -	\$ -	N/A	
02-506-50025	Benefits-Boots & Incentives	\$ 2,619	\$ -	\$ 300	11.45%	
02-506-51003	R&M - Structures	\$ 36,414	\$ 1,986	\$ 5,602	15.38%	
02-506-51091	Expense Credits (overhead)	\$ -	\$ -	\$ -	N/A	
02-506-51120	Safety Equipment & Supplies	\$ 26,010	\$ 1,069	\$ 6,170	23.72%	
02-506-51125	Petroleum Products	\$ 156,060	\$ 5,148	\$ 61,150	39.18%	
02-506-51130	Office Supplies & Expenses	\$ 36,414	\$ 1,374	\$ 6,034	16.57%	
02-506-51140	General Supplies & Expenses	\$ 41,616	\$ 3,069	\$ 9,896	23.78%	
02-506-51199	Disaster Repairs & Incidences	\$ -	\$ -	\$ 780	N/A	
02-506-51211	Utilities - Electricity	\$ 33,293	\$ 4,841	\$ 15,384	46.21%	
02-506-51213	Utilities - Natural Gas	\$ 2,081	\$ -	\$ 139	6.68%	
02-506-54002	Dues & Subscriptions	\$ 31,212	\$ 4,182	\$ 5,761	18.46%	
02-506-54005	Computer Expenses	\$ 150,858	\$ 4,717	\$ 24,768	16.42%	
02-506-54010	Postage	\$ 10,404	\$ -	\$ 2,640	25.37%	
02-506-54011	Printing & Publications	\$ -	\$ -	\$ -	N/A	
02-506-54012	Education & Training	\$ 20,808	\$ 163	\$ 3,167	15.22%	
02-506-54013	Utility Billing Expenses	\$ 232,000	\$ 18,547	\$ 75,005	32.33%	
02-506-54014	Public Relations	\$ 13,500	\$ -	\$ 204	1.51%	
02-506-54016	Travel Related Expenses	\$ 7,803	\$ 1,405	\$ 1,405	18.01%	
02-506-54017	Certifications & Renewals	\$ 12,485	\$ 235	\$ 1,651	13.22%	
02-506-54020	Meeting Related Expenses	\$ 5,000	\$ 51	\$ 1,537	30.73%	
02-506-54022	Utilities - YVWD Services	\$ 100,000	\$ -	\$ 29,500	29.50%	

FY 2021-22 Water Expenses					
G/L ACCOUNT #	DESCRIPTION	BUDGET	Oct '21	Year to Date	%
02-506-54024	Waste Disposal	\$ 9,000	\$ -	\$ 1,365	15.17%
02-506-54025	Telephone & Internet	\$ 46,818	\$ 3,012	\$ 16,490	35.22%
02-506-54099	Conservation & Rebates	\$ 10,000	\$ -	\$ 1,131	11.31%
02-506-54104	Contractual Services	\$ 198,000	\$ 20,437	\$ 54,832	27.69%
02-506-54107	Legal	\$ 31,212	\$ -	\$ 139,109	445.69%
02-506-54108	Audit & Accounting	\$ 15,606	\$ -	\$ 5,000	32.04%
02-506-54109	Professional Fees	\$ 171,666	\$ -	\$ 36,342	21.17%
02-506-55500	Depreciation	\$ 208,080	\$ -	\$ 121,681	58.48%
02-506-56001	Insurance	\$ 104,040	\$ 10,718	\$ 43,256	41.58%
02-506-57030	Regulatory Compliance	\$ 36,414	\$ 2,000	\$ 9,246	25.39%
02-506-57090	Election Related Expenses	\$ -	\$ -	\$ -	N/A
02-506-57095	Yucaipa SGMA	\$ 10,404	\$ -	\$ -	0.00%
02-506-57096	Beaumont Basin Watermaster	\$ 41,616	\$ 1,340	\$ 4,340	10.43%
02-506-57097	San Timoteo SGMA	\$ 5,202	\$ -	\$ -	0.00%
02-506-57098	Bunker Hill GSC	\$ 15,606	\$ -	\$ -	0.00%
02-506-57199	Suspense	\$ -	\$ -	\$ -	
	ADMINISTRATION TOTALS	\$ 2,736,004	\$ 159,380	\$ 986,451	36.05%
02-540-57201	Series 2015A Principal	\$ 1,290,000	\$ -	\$ 1,290,000	100.00%
02-540-57402	Interest - Bond Repayment	\$ 1,006,063	\$ -	\$ 515,931	51.28%
	40 - Debt	\$ 2,296,063	\$ -	\$ 1,805,931	78.65%
02-540-57001	Asset Acq. - Water Dept	\$ -	\$ -	\$ -	--
02-540-57003	Asset Acq. - US Dept	\$ -	\$ -	\$ -	--
02-540-57006	Asset Acq. - Admin Dept	\$ -	\$ -	\$ -	--
02-540-57807	Infrastructure Replacement Fnd	\$ 3,406,486	\$ -	\$ -	0.00%
	40 - Capital Outlay	\$ 3,406,486	\$ -	\$ -	0.00%
	TOTAL WATER EXPENSES	\$ 17,274,066	\$ 672,712	\$ 5,326,761	30.84%

FY 2021-22 Sewer Expenses					
G/L ACCOUNT #	DESCRIPTION	BUDGET	Oct '21	Year to Date	%
03-502-50009	Labor - Overtime	\$ 40,931	\$ 4,238	\$ 17,077	41.72%
03-502-50010	Labor	\$ 1,085,874	\$ 83,129	\$ 332,097	30.58%
03-502-50013	Benefits-FICA	\$ 102,965	\$ 7,183	\$ 28,760	27.93%
03-502-50014	Benefits-Life Insurance	\$ 3,927	\$ 138	\$ 564	14.37%
03-502-50016	Benefits-Health & Def Comp	\$ 217,552	\$ 20,385	\$ 80,907	37.19%
03-502-50017	Benefits-Disability Insurance	\$ 23,959	\$ 1,374	\$ 5,354	22.35%
03-502-50019	Benefits-Workers Compensatn	\$ 70,571	\$ -	\$ 2,571	3.64%
03-502-50021	Benefits-PERS Employee	\$ -	\$ -	\$ (633)	N/A
03-502-50022	Benefits-PERS Employer	\$ 77,743	\$ 5,713	\$ 22,329	28.72%
03-502-50023	Benefits-Uniforms	\$ 5,874	\$ 119	\$ 926	15.77%
03-502-50024	Benefits-Vacation & Sick Pay	\$ -	\$ -	\$ -	N/A
03-502-50025	Benefits-Boots & Incentives	\$ 7,590	\$ -	\$ -	0.00%
03-502-51003	R&M - Structures	\$ 364,140	\$ 73,933	\$ 275,087	75.54%
03-502-51010	R&M - Automation Control	\$ 67,626	\$ -	\$ 20,209	29.88%
03-502-51106	Chemicals	\$ 755,000	\$ 33,948	\$ 211,960	28.07%
03-502-51111	Propane	\$ 520	\$ -	\$ 3,541	680.95%
03-502-51115	Laboratory Supplies	\$ 31,212	\$ -	\$ 392	1.25%
03-502-51140	General Supplies & Expenses	\$ 18,000	\$ 3,982	\$ 7,229	40.16%
03-502-51210	Utilities - Power Purchases	\$ 1,013,372	\$ 669	\$ 201,406	19.87%
03-502-54012	Education & Training	\$ 7,566	\$ -	\$ 200	2.64%
03-502-54025	Telephone & Internet	\$ 5,000	\$ 348	\$ 1,064	21.28%
03-502-54110	Laboratory Services	\$ 88,434	\$ 95	\$ 51,690	58.45%
03-502-57031	Sewage Waste Disposal-Solids	\$ 239,292	\$ -	\$ 67,572	28.24%
03-502-57034	Brineline Operating Expenses	\$ 416,160	\$ 1,060	\$ (64,387)	-15.47%
	TREATMENT TOTALS	\$ 4,643,308	\$ 236,314	\$ 1,265,916	27.26%
03-506-50009	Labor - Overtime	\$ 5,736	\$ 1,779	\$ 4,449	77.55%
03-506-50010	Labor	\$ 601,289	\$ 47,180	\$ 186,261	30.98%
03-506-50011	Labor - Credit	\$ -	\$ -	\$ 2,935	N/A
03-506-50012	Director Fees	\$ 20,000	\$ 2,522	\$ 7,646	38.23%
03-506-50013	Benefits-FICA	\$ 60,028	\$ 3,904	\$ 14,904	24.83%
03-506-50014	Benefits-Life Insurance	\$ 2,839	\$ 67	\$ 318	11.21%
03-506-50016	Benefits-Health & Def Comp	\$ 155,786	\$ 15,130	\$ 63,641	40.85%
03-506-50017	Benefits Disability Insurane	\$ 13,969	\$ 614	\$ 2,367	16.95%
03-506-50019	Benefits-Workers Compensation	\$ 5,861	\$ -	\$ 1,200	20.47%
03-506-50021	Benefits-PERS Employee	\$ -	\$ -	\$ (366)	N/A
03-506-50022	Benefits-PERS Employer	\$ 49,910	\$ 3,675	\$ 311,778	624.68%
03-506-50023	Benefits-Uniforms	\$ -	\$ -	\$ -	N/A
03-506-50024	Benefits-Vacation & Sick Pay	\$ -	\$ -	\$ -	N/A
03-506-50025	Benefits-Boots & Incentives	\$ 2,619	\$ -	\$ -	0.00%
03-506-50055	Pension Expense-GASB 68	\$ -	\$ -	\$ -	N/A
03-506-51120	Safety Equipment & Supplies	\$ 9,884	\$ 616	\$ 2,113	21.38%
03-506-51125	Petroleum Products	\$ 24,970	\$ 2,081	\$ 10,303	41.26%
03-506-51130	Office Supplies & Expenses	\$ 7,283	\$ 678	\$ 3,350	45.99%
03-506-51140	General Supplies & Expenses	\$ 5,000	\$ 50	\$ 1,457	29.13%
03-506-51199	Disaster Repairs & Incidences	\$ -	\$ -	\$ -	N/A

FY 2021-22 Sewer Expenses					
G/L ACCOUNT #	DESCRIPTION	BUDGET	Oct '21	Year to Date	%
03-506-54002	Dues & Subscriptions	\$ 31,212	\$ 3,880	\$ 4,537	14.53%
03-506-54003	Management & Admin Services	\$ 210,681	\$ 17,557	\$ 69,883	33.17%
03-506-54005	Computer Expenses	\$ 124,848	\$ 4,717	\$ 18,715	14.99%
03-506-54011	Printing & Publications	\$ -	\$ -	\$ -	N/A
03-506-54012	Education & Training	\$ 20,400	\$ 322	\$ 2,667	13.08%
03-506-54014	Public Relations	\$ 26,010	\$ -	\$ -	0.00%
03-506-54016	Travel Related Expenses	\$ 10,404	\$ 378	\$ 2,181	20.96%
03-506-54017	Certifications & Renewals	\$ 10,200	\$ 192	\$ 1,122	11.00%
03-506-54019	Licenses & Permits	\$ 72,828	\$ -	\$ 14,636	20.10%
03-506-54020	Meeting Related Expenses	\$ 5,202	\$ 242	\$ 1,482	28.48%
03-506-54022	Utilities - YVWD Services	\$ 500,000	\$ -	\$ 166,727	33.35%
03-506-54024	Waste Disposal	\$ 40,000	\$ -	\$ 6,709	16.77%
03-506-54025	Telephone & Internet	\$ 52,020	\$ 4,918	\$ 21,239	40.83%
03-506-54030	Drinking Water	\$ -	\$ -	\$ -	N/A
03-506-54104	Contractual Services	\$ 47,858	\$ 17,984	\$ 42,841	89.52%
03-506-54107	Legal	\$ 31,212	\$ -	\$ 10,957	35.10%
03-506-54108	Audit & Accounting	\$ 15,606	\$ -	\$ 5,000	32.04%
03-506-54109	Professional Fees	\$ 208,080	\$ -	\$ 157,423	75.65%
03-506-55500	Depreciation	\$ -	\$ -	\$ -	N/A
03-506-56001	Insurance	\$ 135,252	\$ 14,463	\$ 62,213	46.00%
03-506-57030	Regulatory Compliance	\$ 72,828	\$ -	\$ 18,605	25.55%
	ADMINISTRATION TOTALS	\$ 2,579,815	\$ 142,948	\$ 1,219,291	47.26%
03-507-50009	Labor - Overtime	\$ 26,886	\$ 1,576	\$ 7,973	29.65%
03-507-50010	Labor	\$ 638,741	\$ 45,034	\$ 180,658	28.28%
03-507-50011	Labor - Credit	\$ -	\$ -	\$ -	0.00%
03-507-50013	Benefits-FICA	\$ 64,062	\$ 3,731	\$ 15,089	23.55%
03-507-50014	Benefits-Life Insurance	\$ 2,916	\$ 100	\$ 404	13.86%
03-507-50016	Benefits-Health & Def Comp	\$ 170,859	\$ 14,780	\$ 57,560	33.69%
03-507-50017	Benefits-Disability Insurance	\$ 14,907	\$ 735	\$ 2,821	18.93%
03-507-50019	Benefits-Workers Compensatio	\$ 15,250	\$ -	\$ 2,571	16.86%
03-507-50021	Benefits-PERS Employee	\$ -	\$ -	\$ (332)	N/A
03-507-50022	Benefit-PERS Employer	\$ 50,520	\$ 3,483	\$ 13,595	26.91%
03-507-50023	Benefits-Uniforms	\$ 4,092	\$ 81	\$ 596	14.56%
03-507-50024	Benefits-Vacation & Sick Pay	\$ -	\$ -	\$ -	N/A
03-507-50025	Benefits-Boots & Incentives	\$ 7,642	\$ -	\$ -	0.00%
03-507-51003	Sewer Pipeline & Facilities	\$ 250,002	\$ 21,459	\$ 86,490	34.60%
03-507-51140	General Supplies & Expenses	\$ 502	\$ -	\$ 30	5.99%
03-507-51241	Lift Station #1	\$ 52,502	\$ 359	\$ 28,585	54.45%
03-507-51242	Lift Station #2	\$ 18,002	\$ 1,683	\$ 5,098	28.32%
03-507-51243	Lift Station #3	\$ 3,202	\$ 181	\$ 482	15.05%
03-507-51244	Lift Station #4	\$ 9,502	\$ 1,462	\$ 5,128	53.97%
03-507-51246	Lift Station #6	\$ 5,002	\$ 1,110	\$ 2,859	57.16%

FY 2021-22 Sewer Expenses					
G/L ACCOUNT #	DESCRIPTION	BUDGET	Oct '21	Year to Date	%
03-507-51248	Lift Station #8	\$ 2,502	\$ 135	\$ 336	13.45%
03-507-54012	Education & Training	\$ 5,428	\$ -	\$ -	0.00%
03-507-54025	Telephone & Internet	\$ 1,536	\$ 152	\$ 456	29.69%
03-507-54111	Pretreatment	\$ 50,002	\$ -	\$ 21,709	43.42%
	ENVIRONMENTAL CONTROL TOTAL	\$ 1,394,057	\$ 96,062	\$ 432,109	31.00%
03-540-57202	SRF Principal - WWTP	\$ 2,418,402	\$ 2,418,402	\$ 2,418,402	100.00%
03-540-57203	SRF Principal - Brineline	\$ 471,609	\$ -	\$ -	0.00%
03-540-57204	SRF Principal - Wise	\$ 142,676	\$ -	\$ -	0.00%
03-540-57205	SRF Principal - R 10.3	\$ 41,803	\$ -	\$ -	0.00%
03-540-57206	SRF Principal - Crow St	\$ 16,346	\$ -	\$ -	0.00%
03-540-57403	Interest - Long Term Debt	\$ 908,033	\$ 505,267	\$ 505,267	55.64%
	40 - Debt	\$ 3,998,869	\$ 2,923,669	\$ 2,923,669	73.11%
03-540-57002	Asset Acq. - Treatment Dept	\$ -	\$ -	\$ -	N/A
03-540-57006	Asset Acq. - Admin Dept	\$ -	\$ -	\$ -	N/A
03-540-57007	Asset Acq. - EC Dept	\$ -	\$ -	\$ -	N/A
03-540-57807	Infrastructure Replacement Fnd	\$ 520,200	\$ -	\$ -	0.00%
	40 - Capital Outlay	\$ 520,200	\$ -	\$ -	0.00%
	TOTAL SEWER EXPENSES	\$ 13,136,249	\$ 3,398,992	\$ 5,840,984	44.46%

FY 2021-22 Recycled Expenses					
G/L ACCOUNT #	DESCRIPTION	BUDGET	Oct '21	Year to Date	%
04-506-50009	Labor - Overtime	\$ 21,428	\$ 1,180	\$ 4,001	18.67%
04-506-50010	Labor	\$ 701,675	\$ 52,313	\$ 215,336	30.69%
04-506-50011	Labor - Credit	\$ -	\$ -	\$ -	N/A
04-506-50012	Director Fees	\$ -	\$ -	\$ -	N/A
04-506-50013	Benefits-FICA	\$ 67,679	\$ 4,194	\$ 17,282	25.53%
04-506-50014	Benefits-Life Insurance	\$ 2,654	\$ 96	\$ 385	14.52%
04-506-50016	Benefits-Health & Def Comp	\$ 160,108	\$ 15,257	\$ 61,377	38.33%
04-506-50017	Benefits-Disability Insurance	\$ 15,747	\$ 812	\$ 3,281	20.84%
04-506-50019	Benefits-Workers Compensation	\$ 10,862	\$ -	\$ 1,800	16.57%
04-506-50021	Benefits-PERS Employee	\$ -	\$ -	\$ -	N/A
04-506-50022	Benefits-PERS Employer	\$ 57,041	\$ 4,221	\$ 17,095	29.97%
04-506-50023	Benfits-Uniforms	\$ 1,716	\$ 15	\$ 112	6.51%
04-506-50024	Benefits-Vacation & Sick Pay	\$ -	\$ -	\$ -	N/A
04-506-50025	Benefits-Boots & Incentives	\$ 7,654	\$ -	\$ -	0.00%
04-506-51003	R&M - Structures	\$ 15,606	\$ 138	\$ 253	1.62%
04-506-51011	R&M - Valves	\$ 24,000	\$ -	\$ -	0.00%
04-506-51020	R&M - Pipelines	\$ 24,000	\$ -	\$ -	0.00%
04-506-51021	R&M - Service Lines	\$ 2,081	\$ 1,780	\$ 1,780	85.54%
04-506-51022	R&M - Fire Hydrants	\$ 2,081	\$ -	\$ 7	0.33%
04-506-51030	R&M - Meters	\$ 1,561	\$ -	\$ 3,728	238.84%
04-506-51140	General Supplies & Expenses	\$ 3,121	\$ 945	\$ 1,777	56.93%
04-506-51210	Utilities - Power Purchases	\$ 99,735	\$ 12,961	\$ 41,917	42.03%
04-506-54002	Dues & Subscriptions	\$ 3,121	\$ 3,025	\$ 3,034	97.21%
04-506-54005	Computer Expenses	\$ 5,202	\$ -	\$ 1,803	34.66%
04-506-54011	Printing & Publications	\$ -	\$ -	\$ -	N/A
04-506-54012	Education & Training	\$ 3,641	\$ -	\$ 1,097	30.13%
04-506-54014	Public Relations	\$ 4,370	\$ -	\$ -	0.00%
04-506-54016	Travel Related Expenses	\$ 1,040	\$ -	\$ -	0.00%
04-506-54017	Certifications & Renewals	\$ 520	\$ -	\$ -	0.00%
04-506-54019	Licenses & Permits	\$ 14,000	\$ 370	\$ 370	2.64%
04-506-54020	Meeting Related Expenses	\$ 1,457	\$ -	\$ 284	19.51%
04-506-54022	Utilities - YVWD Services	\$ 13,005	\$ -	\$ 2,773	21.32%
04-506-54025	Telephone & Internet	\$ 1,457	\$ 120	\$ 637	43.69%
04-506-54104	Contractural Services	\$ 30,000	\$ 287	\$ 4,018	13.39%
04-506-54107	Legal	\$ 520	\$ -	\$ -	0.00%
04-506-54108	Audit & Accounting	\$ 6,800	\$ -	\$ 5,000	73.53%
04-506-54109	Professional Fees	\$ 20,000	\$ -	\$ 1,434	7.17%
04-506-54110	Laboratory Services	\$ -	\$ -	\$ -	N/A
04-506-55500	Depreciation	\$ -	\$ -	\$ -	N/A
04-5-06-56001	Insurance	\$ 26,010	\$ 2,382	\$ 9,527	36.63%
04-5-06-57030	Regulatory Compliance	\$ 6,763	\$ -	\$ 50	0.74%
04-5-06-57040	Environmental Compliance	\$ 520	\$ -	\$ -	0.00%
	TOTAL RECYCLED EXPENSES	\$ 1,357,175	\$ 100,095	\$ 400,156	29.48%



Date: November 16, 2021

Task: 89496

Prepared By: Mike Rivera, Public Works Manager

Subject: Status Report on the Installation of a Temporary 4-Inch HDPE High-Line Near Knoll Drive, Yucaipa

Recommendation: Staff presentation - no action required.

Project Overview

On May 28, 2021, a drinking water mainline split which impacted the property at 11945 Pendleton Road, Yucaipa. District crews repaired the mainline the same day. The repair to the property where the mainline failed is being repaired by the District's insurance company and was discussed on June 22, 2021 [Director Memorandum 21-118]. District staff is in the process of preparing a design for a new pipeline alignment within Knoll Drive which will provide a permanent installation of 8-inch Ductile Iron Pipe (DIP) which will be discussed at a future Board Meeting.

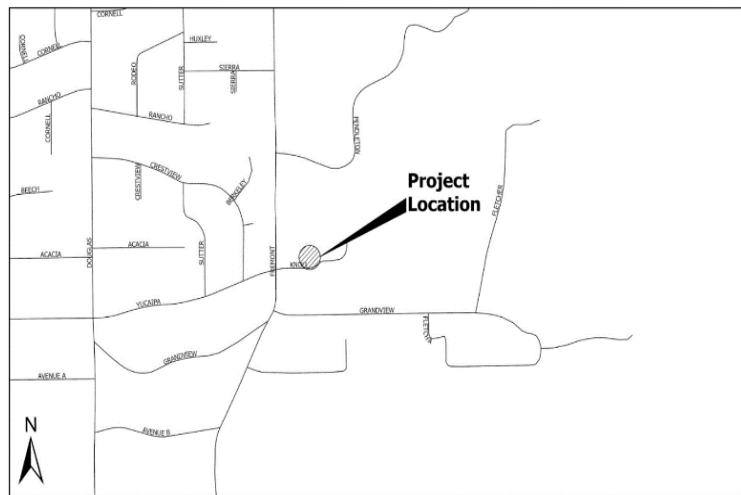

LOCATION MAP

This installation of a 4-inch High Density Polyethylene (HDPE) is temporary. The purpose of the temporary HDPE line is to replace the existing fragile mainline that failed, causing the damage to 11945 Pendleton Road. The highline pipeline consists of approximately 1,000 ± linear feet of 4-inch High-Density Polyethylene (HDPE) including various valves, appurtenances, and water connections.

Status Update

Currently, the temporary highline has been completed by the contractor Rain for Rent. The District's contractor installed approximately 1,000 linear feet of HDPE pipe which includes fusing forty-foot lengths of pipe and six (6) tees for customer water services. The fusing of pipe and fittings makes this highline one continuous segment of pipe. The contractor also performed a hydrostatic pressure test pipeline at 190psi, which held for one hour per manufacturers specifications. District staff secured the position of the alignment with numerous stakes. District staff chlorinated the highline, sampled for water quality, and reinstalled six water services to the near residents. The highline is now providing the water service for six residential customers and will be in place until the permanent water main is installed.









Date: November 16, 2021 **Task:** Not Applicable

Prepared By: Joseph B. Zoba, General Manager

Subject: Consideration of Proposal from Redistricting Insights for Professional Services Related to the Revision of Division Boundaries

Recommendation: That the Board authorize the General Manager to execute a contract with Redistricting Insights for a sum not to exceed \$10,000.

Every ten years, the District is required to review and redraw the division boundaries for the five elected officials. This process, called redistricting, ensures all divisions remain balanced with the same number of constituents.

On October 19, 2021, the District conducted our first public hearing related to the redistricting process for redrawing division boundaries [Director Memorandum No. 21-169].

The District staff has received, reviewed, and recommends authorization to utilize the services from Redistricting Insights to provide technical assistance for the redistricting process.

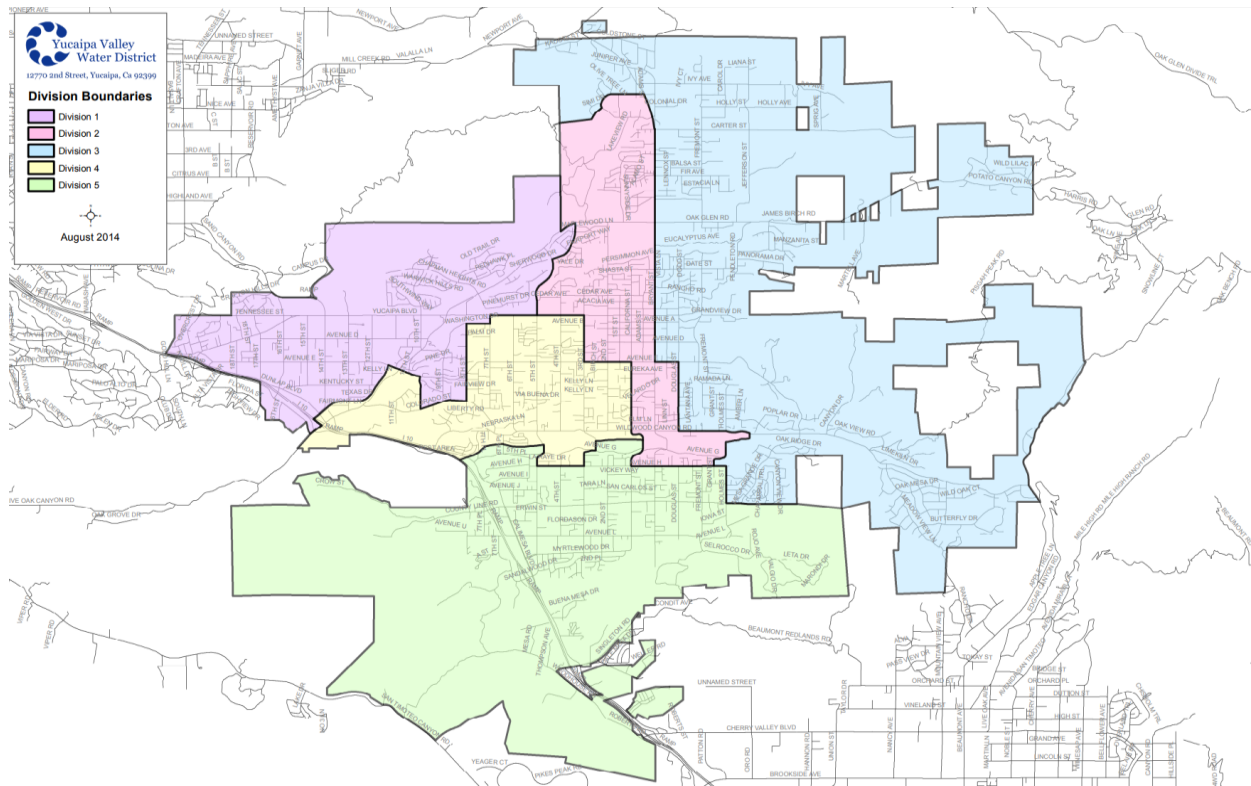

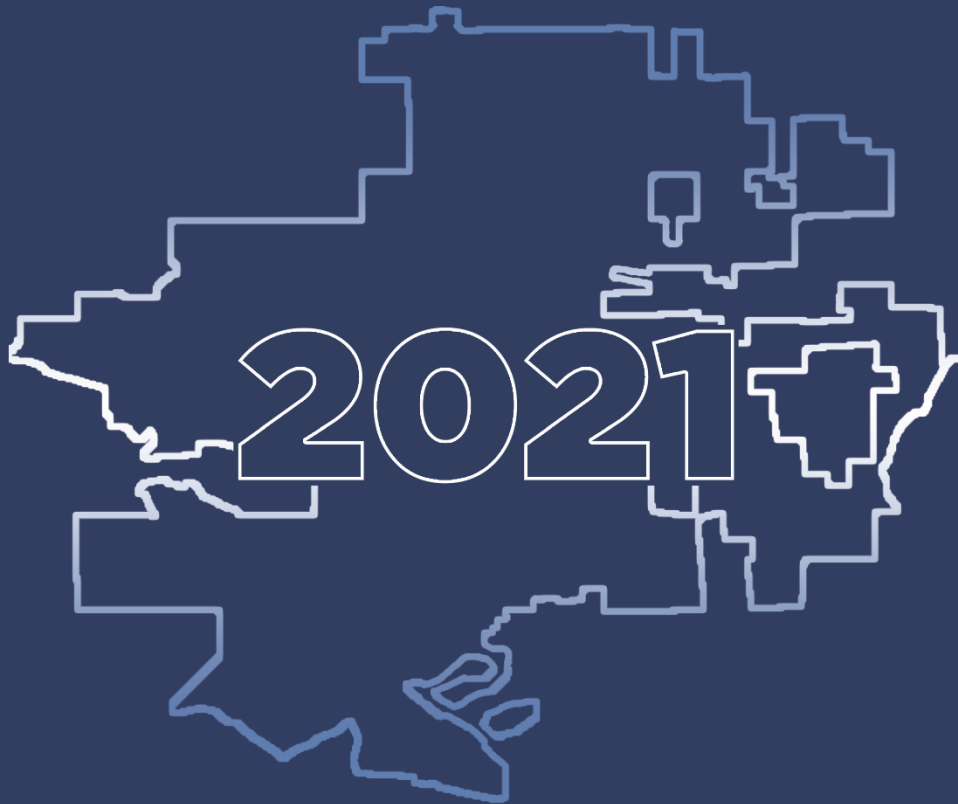

Redistricting Services Proposal

Prepared for Yucaipa Valley Water District

Submitted on October 20th, 2021



Joseph Zoba, General Manager
Yucaipa Valley Water District
12770 Second Street
Yucaipa, CA 92399

Dear Mr. Zoba,

Redistricting Insights welcomes the opportunity to work with the Yucaipa Valley Water District to help you accomplish your goal of enacting balanced and representative district lines for your board of directors elections.

Redistricting Insights is a premier redistricting firm currently working on advocacy and demography projects across the country. Our team combines a data-driven approach that utilizes cutting-edge technology with an extensive knowledge base spanning the past two decades of redistricting cycles. We have worked with municipalities, counties, and special districts across the state to help manage redistricting in an open, transparent, and fair way.

Our team has also worked with public agencies in a variety of communications, community engagement, and consulting roles apart from redistricting—giving us a unique ability to work with your staff to solve problems and deliver the highest quality of service for your constituents.

This redistricting cycle, our team has contracted with a number of stakeholder groups to work on analysis and advocacy efforts on the statewide level in California and several other states. In addition, we have contracted with several public agencies to manage redistricting in their jurisdictions.

In this proposal, you will find our agency client list and references, our project proposal, a proposed timeline for this project and a fee proposal.

If you have any questions about the content of this proposal, please do not hesitate to reach out. We look forward to working with you.

Sincerely,



Matt Rexroad
Chief Legal Counsel
Redistricting Insights, LLC

Description of Experience



Matt Rexroad, Chief Legal Counsel

Matt Rexroad earned his undergraduate degree from the University of Southern California, a Juris Doctor degree from McGeorge School of Law while working full time in the State Legislature, and a Masters of Public Administration from the University of Southern California Sacramento Center. He is an active member of the California State Bar. Matt was a founding partner at Meridian Pacific, Inc., a nationwide strategic political consulting and public affairs firm. He also served as a senior staff person in the California state legislature. Rexroad served four years on the Woodland City Council and twelve years on the Yolo County Board of Supervisors.

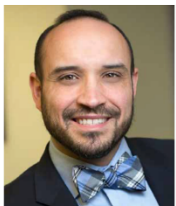

Fabian Valdez Jr., Chief Demographer

Fabian Valdez has a proven track record of integrating data analytics and predictive modeling to form quantitative strategies to drawing districts. Valdez's approach is to let the data tell the story. Fabian has worked on data analytics projects across the State of California, including serving as the Director of Data and Digital Marketing at Meridian Pacific Inc. prior to joining Redistricting Insights. Fabian is responsible for onboarding the 2020 Census data and ensuring that future models and redistricting projects accurately reflect the changing nature of California demographics.



Eddy Harrity, Data Scientist

Eddy Harrity received both his Bachelor's and Master's degrees from Pepperdine University, where he researched incentivizing candidates to represent the median voter and the effects of the top-two primary on the partisanship of California Legislators. He has worked on campaigns from California to New Hampshire, focusing on voter behavior and data analytics.



Ryan Gardiner, Communications Director

Ryan Gardiner is a seasoned communications professional with a track record of engaging communities to achieve deliberate public affairs outcomes. Ryan has previously worked in strategic political consulting for Meridian Pacific, Inc. and as a policy and communications aide in the California State Senate. Ryan graduated from UC Davis with a degree in political science and earned a graduate certificate in applied public policy from the Center for California Studies at Sacramento State.



Client References

The team at Redistricting Insights has a breadth of experience that covers all aspects of the redistricting process. We have been contracted as redistricting consultants for various municipal and county governing bodies as well as for community interests.

The following are a few examples of previous projects similar in scope to this proposal:

City of Elk Grove 2011 Council Districting

- Client Name: City of Elk Grove
- Project Description: Assisting with transitioning from at-large to district elections
- Contact: Gary Davis, 916-705-9538

Chualar Union Elementary 2011 Districting

- Client Name: Chualar Union Elementary School District
- Project Description: Assisting with transitioning from at-large to district elections (2011)
- Contact: Ginny Brown, 831-755-0303

Salinas Memorial Hospital 2011 Districting

- Client Name: Salinas Valley Memorial Hospital District
- Project Description: Assisting with transitioning from at-large to district elections (2011)
- Contact: 831-757-3627

State Redistricting for the California Business Roundtable

- Client Name: California Business Roundtable
- Project Description: Monitoring and advising on the state redistricting process
- Contact: Shaudi Fulp, 415-310-3512

Current Public Redistricting Clients

San Bernardino County
 City of Barstow
 Cherry Valley Beaumont Water District
 South Placer Municipal Utilities District
 Monterey Peninsula Regional Park District
 Cordova Recreation and Park District
 Salinas Valley Memorial Hospital District
 Alan Hancock Community College District
 New York Independent Redistricting Commission



Project Proposal

The objective of this project is to assist the Yucaipa Valley Water District with drawing a legally permissible map for your Board of Directors elections. This includes compliance with the California and federal Voting Rights Acts, the Fair Maps Act, and ensuring an open, accessible, transparent process that engages constituents in your district.

The Redistricting Insights team will assist district staff in developing a timeline, plan, agenda/board materials, community engagement materials, and advise on the drawing of maps.

Analysis

The first step in beginning the redistricting process is working with district staff to conduct an analysis of current district boundaries and prepare a report to the board of directors about the process and options available to them moving forward. That analysis will show if it is legally permissible for the current district boundaries to be re-adopted or if they need to be adjusted to reach population equality.

Draft Maps

Should the board decide to readopt current trustee boundaries, we would assist district staff in preparing a resolution doing so. Should new boundaries need to be adopted, we would work with staff to prepare draft maps for the board and public to deliberate on. While YVWD GIS staff will be responsible for doing the physical mapping of new boundaries, we will provide input and direction to ensure that relevant state and federal law, as well as basic redistricting principles, are adhered to.

Our team will assist in presenting the board with the draft map and be available to answer any questions they may have.

Final Maps

Once the board affirmatively adopts new district boundaries or readopts current boundaries, district staff will need to transmit the new maps to county elections staff.



Proposed Schedule

The State of California gives more flexibility during the redistricting process to water districts than to Cities and Counties. As such, the timeline for this project can largely be determined by staff and board direction. Meetings to discuss redistricting may be incorporated into the regular meetings of the Board of Directors.

Late 2021

- Meet with district staff and develop a custom plan for the District's redistricting.
- Develop and publish information about the YVMD redistricting process.
- Assist district staff in developing a Redistricting Basics presentation for the Board of Directors along with an initial analysis of current district boundaries.
- Board of Directors will give direction on how they would like to proceed.
- Redistricting Insights will advise district GIS staff on best practices in preparing the adjusted boundaries (if applicable).

Early 2022

- Should it be the preference of the board to readopt current boundaries, a resolution doing so will be proposed to the Board of Directors for adoption..
- Should it be the preference of the board to adjust current boundaries, a draft map will be proposed to the board for adoption.
- In order to accommodate adequate public comment, we recommend allowing multiple meetings and ample ability for public comment in the event that a revised map is considered by the board.
- Upon adoption of a final draft, Redistricting Insights will advise district staff in transmitting the final maps to the County Registrar of Voters.



Proposed Fee

The below cost proposal includes all services described in this proposal:

- Mapping support
- Technical support
- Public hearing coordination

Cost: \$10,000



Date: November 16, 2021

Prepared By: Matthew Porras, Implementation Manager

Subject: Consideration to Purchase Four Service Trucks for the Public Works Department

Recommendation: That the Board authorize the purchase of vehicles from Transwest Truck Center for a sum not to exceed \$414,134.95 and adopt Resolution No. 2021-54 Transferring Reserve Funds for the vehicle purchase.

The District staff has identified several vehicles that should be considered for replacement based on cost of ownership, reliability, and safety. Multiple competitive models and manufacturers were considered during the selection process, but the District identified the Ford F-Series as a versatile and economical choice to replace various aging vehicles currently in the District’s fleet. The objective of fleet management is to maintain safe, efficient, and reliable vehicles that strike an appropriate balance of age and cost of ownership.

In compliance with the District’s procurement policy and to ensure the District receives a fair price, several Ford dealers were contacted to provide quotes for the vehicles. The table below summarizes the quotes. Note that Fairview Ford is included in the table yet after working through all of the details of the quotes, they will need to wait until the spring of 2022 to be able to finalize the quotes. Understanding the supply chain issues with new vehicle production, District staff recommends the order and purchase of the vehicles listed below.

Vehicle	Phenix Truck Bodies	Transwest Truck Center	Fairview Ford
Utility/Crane Truck	\$156,805.89	\$131,435.33	Quote Delayed
Dump Truck	\$92,758.99	\$81,988.86	Quote Delayed
Flat Bed	\$72,541.43	\$69,275.43	Quote Delayed

Vehicle		Estimated Costs Based on Recent Quotes		
Make	Model	Cost Each	Quantity	Total
Ford	F-550	\$131,435.33	2	\$262,870.66
Ford	F-600	\$81,988.86	1	\$81,988.86
Ford	F-600	\$69,275.43	1	\$69,275.43
				\$414,134.95

Funding for these vehicles will be from Water and Sewer Infrastructure Reserves [GL Accounts #02-000-10311 and 03-000-10311]. Resolution No. 2021-54 would approve the transfer of funds

from the District Reserve Funds to the Water Fund and Sewer Funds for the purchase of these trucks.

**RESOLUTION OF THE YUCAIPA VALLEY WATER DISTRICT
TRANSFERRING FUNDS WITHIN BOTH THE WATER FUND AS TRANSFER
NUMBER 3 AND SEWER FUNDS AS TRANSFER NUMBER 4 FOR
FISCAL YEAR 2022**

WHEREAS, the Yucaipa Valley Water District recognizes the importance of funding projects and capital purchases within the District with funds set aside for this purpose, and

WHEREAS, the Board of Directors has approved the purchase of four Ford Super Duty Trucks for a sum not to exceed \$414,134.95, and

NOW, THEREFORE, the Board of Directors of the Yucaipa Valley Water District hereby RESOLVE, DETERMINE, and ORDER as follows:

Section 1: Fund Transfer No. 3 in the amount of \$207,067.48 from the Water Fund Infrastructure Reserves (02-000-10311) to fund 50% of the purchase of the trucks, as well as

Section 2: Fund Transfer No. 4 in the amount of \$207,067.47 from the Sewer Fund Infrastructure Reserves (03-000-10311) to fund 50% of the purchase of the trucks.

PASSED, APPROVED and ADOPTED this 16th day of November 2021.

YUCAIPA VALLEY WATER DISTRICT

Chris Mann, President Board of Directors

ATTEST:

Joseph B. Zoba, General Manager



SALES (909) 770-5170
 PARTS (909) 770-5180
 SERVICE (909) 770-5620
 10150 Cherry Ave
 Fontana CA 92335

WWW.TRANS-WEST.COM
TransWest Truck Center is a Division of Velocity Vehicle Group

Buyers Order

Deal#: DE-87560
 Opp#: 2021-135282
 Date: 10/21/2021

Contact: David Pratt - Mobile: 951-515-4352 - Email: dpratt@trans-west.com

Bill To: PROS-140375
 YUCAIPA VALLEY WATER DIST
 12770 2ND ST
 YUCAIPA CA 92399 County: San Bernardino
 Phone: (909) 797-5117
 mporras@yvwd.us

Ship To:

Unit#:	Stock#:	New 2022 FORD F550	Price:	\$121,887.00
VIN:		GVW: 19500	Color: White	
To Be Delivered On or About: 04/21/2022			Unit Price:	\$121,887.00

Sub Total	\$121,887.00
Doc Fee	\$85.00
CA Tire Recycle Fee	\$10.50
Sales Tax (7.750%)	\$9,452.83
Total Vehicle Sale Price	\$131,435.33
Net Total	\$131,435.33

Lienholder: None

Crane Truck.

ONLY THOSE ITEMS AND SERVICES SPECIFICALLY WRITTEN ON THIS ORDER ARE INCLUDED IN THE STATED PRICE.

ANY OTHER AGREEMENTS, UNLESS IN WRITING, ARE NOT BINDING ON SELLER.

The numbered pages of this Order comprise the entire agreement affecting this purchase and no other agreement or understanding of any nature concerning this purchase has been made or entered into, or will be recognized. I hereby certify that no credit has been extended to me for the purchase of this motor vehicle except as appears in writing on the face of this agreement. I have read and understand the final page of this agreement and agree to it as a part of this order the same as if it were printed above my signature. I certify that I am of legal age, or older, that I have legal capacity and authority to execute this agreement on behalf of my company, and hereby acknowledge receipt of a copy of this order.

YUCAIPA VALLEY WATER DIST

 (Purchaser's Name)

David Pratt

 (Salesperson Name)

X

 (Purchaser's Signature)

 (Approved By)

 Date

 Date

1. TRADE-IN(S). Purchaser shall deliver trade-in(s) in the same condition as at the time of inspection and appraisal by Seller reasonable wear and tear excepted, except as disclosed in the Agreement. Purchase represents that each truck shall be free and clear of all liens and encumbrances and warrants that the trade-in(s) are that type and condition described in this Agreement, including any attachments hereto.

2. TERMS OF PAYMENT. Unless otherwise agreed, net payment shall be due on delivery. Late payments shall bear interest at the rate of 18% per annum, or the maximum permitted by law, whichever is less. If acceptance of delivery is delayed by Purchaser, payment shall become due on the date when Seller is prepared to deliver. If the financial condition of Purchaser at any time does not, in the judgment of Seller, justify continuance of the work to be performed by Seller hereunder on the terms of payment as agreed upon, Seller may suspend such work, or postpone delivery, and require such assurances of Purchaser's performance as Seller deems adequate, including payment in advance, or Seller may cancel this order and shall receive reimbursement for its reasonable and proper cancellation charges. In the event of bankruptcy or insolvency of Purchaser, voluntary or involuntary, Seller shall be entitled to cancel any order then outstanding at any time and seek reimbursement for its reasonable and proper cancellation charges.

3. CANCELLATION. Purchaser may cancel this order only if Seller is able to cancel said order with the manufacturer, and only upon written notice. Upon cancellation or failure to accept delivery, Purchaser shall pay Seller reasonable cancellation changes and expenses, not to be less than Seller's out-of-pocket expenses including carrying costs.

4. SALES AND OTHER TAXES. Unless otherwise specified herein, Seller's price does not include federal excise, sales, use, or other taxes. Consequently, in addition to the price specified herein, the amount of any other excise, sales, use or other taxes (Purchase applicable) to the sale or use of the trucks purchased hereunder shall be paid by Purchaser, or in lieu thereof Purchaser shall provide Seller with a tax exemption certificate acceptable to the taxing authorities. Purchaser agrees that all taxes related to this transaction, whether arising at the time of the transaction or in the future, are Purchaser's responsibility and further agrees to promptly pay any such taxes.

5. DELIVERY. All trucks furnished hereunder shall be delivered to Purchaser at the Seller's dealership location or other location as designated in this Agreement. Unless otherwise provided, delivery will be made via carriers and routes designated by manufacturer with freight charges to be included in the purchase price. Delivery dates are approximate and are based upon receipt of all necessary information from Purchaser. Seller shall not be liable for delays in delivery or manufacturing, or other causes beyond Seller's control.

6. TECHNICAL CHANGES. Purchaser acknowledges that the manufacturer and Seller reserve the right to change the specifications of the truck(s) at any time without obligation to make such changes in other trucks previously delivered to Purchaser. In addition, manufacturer and Seller reserve the right to make design changes and substitution of materials subsequent to the receipt of the order which, in manufacturer's or Seller's opinion are necessary to improve the truck. Purchaser agrees to accept any such changes as fulfillment of Seller's obligations under this order.

7. REQUIRED EQUIPMENT. This order shall be deemed to include, whether or not specified herein, all equipment or accessories required by the National Highway Traffic Safety Act or other regulations in effect at the time of order of receipt. It is agreed that any additional or different equipment not specified which is required at the time of delivery to meet the foregoing Act or other regulations will be added and the costs shall be paid by Purchaser. Purchaser understands that certain safety equipment is available that is not legally required and is available at Purchaser's request for an additional fee.

8. TITLE AND REMEDIES. Until full payment by Purchaser of all amounts due hereunder, Seller reserves the title to all equipment furnished hereunder. If Purchaser defaults in payment or performance hereunder or becomes subject to insolvency, receivership, or bankruptcy proceedings, or makes an assignment for the benefit of creditors, or without the consent of Seller voluntarily or involuntarily sells, transfers, leases, or permits any lien or attachment on the equipment delivered hereunder, Seller may treat all amounts then or thereafter owing hereunder by Purchaser as immediately due and payable (subject only to credits required by law) and Seller may repossess said equipment by any means available by law and shall enjoy any and all other remedies of a secured creditor under the Uniform Commercial Code. Purchaser shall execute and deliver to Seller such financing statements and other documents, as Seller may deem appropriate to evidence, perfect, and protect the priority of its security interest in the truck(s) subject to this order.

9. GENERAL. Any assignment by Purchaser of this order or any rights hereunder, without written consent of Seller, shall be void. Clerical errors in this order may be automatically corrected by giving written notice thereof to Purchaser by a duly authorized representative of Seller. No waiver, alteration, or modification of any of the provisions hereof shall be binding unless and until in writing and signed by a duly authorized representative of Seller. To the extent not covered by other terms herein, including terms of warranty and limitation of liability, etc., the provisions of the Uniform Commercial Code shall govern this sale.

10. IMPORT TARIFFS: Purchaser acknowledges that any import tariffs imposed by the government are the sole responsibility of the Purchaser and will result in an increase in the Seller's price equal to the amount of the obligatory tariff.

This Agreement (including by reference the provisions set out in manufacturer's standard warranty or warranties) shall constitute the entire agreement between Purchaser and Seller, and no understandings or obligations not expressly set forth herein or in manufacturer's standard warranty or warranties are binding upon Purchaser or Seller.

ALL WARRANTIES, IF ANY, BY A MANUFACTURER OR SUPPLIER OTHER THAN SELLER ARE THEIRS, NOT SELLER'S, AND ONLY SUCH MANUFACTURER OR OTHER SUPPLIER SHALL BE LIABLE FOR PERFORMANCE UNDER SUCH WARRANTIES. SELLER HEREBY DISCLAIMS ALL WARRANTIES, EXPRESS OR IMPLIED, INCLUDING ANY IMPLIED WARRANTIES OF MERCHANTABILITY OR FITNESS FOR A PARTICULAR PURPOSE.

Accepted and Agreed by: _____
(Company Name)

(Date)

Signor's Name and Title: _____
(Please Print Name and Title. Must be an Officer of the company
Authorized to approve capital purchases.)

X _____
(Signature)

Oct 21 2021 3:20PM

Skaug Truck Body Works

1404 First Street
 San Fernando, CA 91340
 (818) 365-9123

Estimate

Date	Estimate #
10/18/2021	3667

Name / Address
Trans West Truck Center 10150 Cherry Ave. Fontana, CA 92335

Project

Item	Description	Qty	Cost	Total
Resale	11' utility / crane body 42" high x 22 deep compartments Passenger side front compartment 6-drawer set 1-6", 2-4", 3-3" Passenger side rear compartment reinforced for crane ET25KX Venturo crane with wireless/proportional controls Manual outriggers slide out/crank down 20" work bench with tool box under bench each side Driver side front compartment 7- drawer set all 4" Adjustable shelves in balance of compartment Interior slide locks Interior compartment lights with switches in each compartment Headboard/ window protection 2- Work lights mounted to headboard 2- Work lights mounted to rear of body 2- strobe lights on rear 2- strobe lights on front grill 2- flush mounted strobe lights mouted in wheel wells Air compressor with 13HP Honda engine mounted at front of bed 3/8 x 50' air hose reel mounted in passenger side rear compartment with hose access thru rear panel Quick disconnect for at rear Driver side rear compartment with 3500 watt inverter Aux. Battery for inverter vent compartment for battery 50' 12 ga. electric cord reel inside compartment with cord access thru rear panel Cone holders on front bumper			
			Subtotal	
			Sales Tax (10.25%)	
			Total	

Skaug Truck Body Works

1404 First Street
 San Fernando, CA 91340
 (818) 365-9123

Estimate

Date	Estimate #
10/18/2021	3667

Name / Address
Trans West Truck Center 10150 Cherry Ave. Fontana, CA 92335

Project

Item	Description	Qty	Cost	Total
	Mount backup camera Full rear step bumper on work bench 2- fold down steps on rear bumper 2- grab handles on rear of body 3/8 plate 11" x 11" on passenger side rear corner of work bench HD Wilton model C-1 vise mounted on work bench 3" receiver hitch 7-way RV style trailer plug Painted and installed For: Yucaipa Water District			
			Subtotal	
			Sales Tax (10.25%)	
			Total	

Prepared for: Matthew Porras, Yucaipa Valley Water District

12770 Second Street

Yucaipa, CA 92399

Office: 909-790-3300

Email: mporras@yvwd.us

Crane Spec.

2022 F-550 Chassis 4x4 SD Crew Cab 203" WB DRW XL (W5H)

Price Level: 240



Client Proposal

Prepared by:

David Pratt

Office: 909-770-5195

Quote ID: YVWDcrane1

Date: 10/13/2021



Transwest Truck Center | 10150 Cherry Ave., Fontana, California, 923355222

Office: 909-770-5620

Prepared for: Matthew Porras

Yucaipa Valley Water District

Prepared by: David Pratt

10/13/2021

Transwest Truck Center | 10150 Cherry Ave. Fontana California | 923355222

**2022 F-550 Chassis 4x4 SD Crew Cab 203" WB DRW XL (W5H)**

Price Level: 240 | Quote ID: YVWDcrane1

As Configured Vehicle**Description****Base Vehicle**

Base Vehicle Price (W5H)

Packages**Order Code 660A***Includes:*

- Engine: 7.3L 2V DEVCT NA PFI V8 Gas
- Transmission: TorqShift 10-Speed Automatic
- 10R140 with neutral idle and selectable drive modes: normal, tow/haul, eco, deep sand/snow and slippery.
- Tires: 225/70Rx19.5G BSW A/P
- Wheels: 19.5" x 6" Argent Painted Steel
- Hub covers/center ornaments not included.
- HD Vinyl 40/20/40 Split Bench Seat
- Includes center armrest, cupholder, storage and driver's side manual lumbar.
- Radio: AM/FM Stereo w/MP3 Player
- Includes 6 speakers.
- SYNC Communications & Entertainment System
- Includes enhanced voice recognition, 911 Assist, 4.2" LCD center stack screen, AppLink, 1 smart-charging USB port and steering wheel audio controls.

Powertrain

Engine: 7.3L 2V DEVCT NA PFI V8 Gas

Transmission: TorqShift 10-Speed Automatic

10R140 with neutral idle and selectable drive modes: normal, tow/haul, eco, deep sand/snow and slippery.

Limited Slip w/4.88 Axle Ratio

GVWR: 19,500 lb Payload Plus Upgrade Package

*Includes upgraded frame, rear-axle and low deflection/high capacity springs. Increases max RGAWR to 14, 706. Note: See Order Guide Supplemental Reference for further details on GVWR.***Wheels & Tires**

Tires: 225/70Rx19.5G BSW A/P

Wheels: 19.5" x 6" Argent Painted Steel

*Hub covers/center ornaments not included.***Seats & Seat Trim**

HD Vinyl 40/20/40 Split Bench Seat

*Includes center armrest, cupholder, storage and driver's side manual lumbar.***Other Options**

Monotone Paint Application

203" Wheelbase

Prices and content availability as shown are subject to change and should be treated as estimates only. Actual base vehicle, package and option pricing may vary from this estimate because of special local pricing, availability or pricing adjustments not reflected in the dealer's computer system. See salesperson for the most current information.

Prepared for: Matthew Porras

Yucaipa Valley Water District

Prepared by: David Pratt

10/13/2021

Transwest Truck Center | 10150 Cherry Ave. Fontana California | 923355222



2022 F-550 Chassis 4x4 SD Crew Cab 203" WB DRW XL (W5H)

Price Level: 240 | Quote ID: YVWDcrane1

As Configured Vehicle (cont'd)**Description****Radio: AM/FM Stereo w/MP3 Player***Includes 6 speakers.**Includes:**- SYNC Communications & Entertainment System**Includes enhanced voice recognition, 911 Assist, 4.2" LCD center stack screen, AppLink, 1 smart-charging USB port and steering wheel audio controls.***Power Equipment Group***Deletes passenger side lock cylinder. Includes upgraded door-trim panel.**Includes:**- Accessory Delay**- Advanced Security Pack**Includes SecuriLock Passive Anti-Theft System (PATS) and inclination/intrusion sensors.**- Folding Trailer Tow Mirrors w/Power Heated Glass**Includes manual telescoping, heated convex spotter mirror and integrated clearance lamps/turn signals.**- MyKey**Includes owner controls feature.**- Power Front & Rear Side Windows**Includes 1-touch up/down driver/passenger window.**- Power Locks**- Remote Keyless Entry***Transfer Case Skid Plates****6-Ton Hydraulic Jack****Dual 78 AH Battery****397 Amp Alternators****Utility Lighting System***Includes LED side-mirror spotlights.***Trailer Brake Controller***Includes smart trailer tow connector. Verified to be compatible with electronic actuated drum brakes only.***Platform Running Boards****Center High-Mounted Stop Lamp (CHMSL)****Rear View Camera & Prep Kit***Pre-installed content includes cab wiring and frame wiring to the rear most cross member. Upfitters kit includes camera with mounting bracket, 20' jumper wire and camera mounting/aiming instructions.***Exterior Backup Alarm (Pre-Installed)****Emissions****50-State Emissions System****Interior Color****Medium Earth Gray**

Prices and content availability as shown are subject to change and should be treated as estimates only. Actual base vehicle, package and option pricing may vary from this estimate because of special local pricing, availability or pricing adjustments not reflected in the dealer's computer system. See salesperson for the most current information.

Prepared for: Matthew Porras

Yucaipa Valley Water District

Prepared by: David Pratt

10/13/2021

Transwest Truck Center | 10150 Cherry Ave. Fontana California | 923355222



2022 F-550 Chassis 4x4 SD Crew Cab 203" WB DRW XL (W5H)

Price Level: 240 | Quote ID: YVWDcrane1

As Configured Vehicle (cont'd)

Description

Exterior Color

Oxford White

Prices and content availability as shown are subject to change and should be treated as estimates only. Actual base vehicle, package and option pricing may vary from this estimate because of special local pricing, availability or pricing adjustments not reflected in the dealer's computer system. See salesperson for the most current information.

Prepared for: Matthew Porras

Yucaipa Valley Water District

Prepared by: David Pratt

10/13/2021

Transwest Truck Center | 10150 Cherry Ave. Fontana California | 923355222



2022 F-550 Chassis 4x4 SD Crew Cab 203" WB DRW XL (W5H)

Price Level: 240 | Quote ID: YVWDcrane1

Selected Equip & Specs

Dimensions

- Exterior length: 289.2"
- Exterior width: 80.0"
- Wheelbase: 203.0"
- Rear track: 74.0"
- Rear tire outside width: 93.9"
- Front legroom: 43.9"
- Front headroom: 40.8"
- Front hiproom: 62.5"
- Front shoulder room: 66.7"
- Passenger volume: 131.7cu.ft.
- Maximum cargo volume: 52.1cu.ft.
- Cab to axle: 84.0"
- Exterior height: 81.7"
- Front track: 74.8"
- Turning radius: 28.6'
- Min ground clearance: 8.2"
- Rear legroom: 43.6"
- Rear headroom: 40.4"
- Rear hiproom: 64.7"
- Rear shoulder room: 65.9"
- Cargo volume: 52.1cu.ft.

Powertrain

- 350hp 7.3L OHV 16 valve V-8 engine with DEVCT variable valve control, SMPI
- federal
- Part-time
- Fuel Economy Cty: N/A
- Recommended fuel : regular unleaded
- TorqShift 10 speed automatic transmission with overdrive
- * **Limited slip differential**
- Fuel Economy Highway: N/A

Suspension/Handling

- Front Mono-beam non-independent suspension with anti-roll bar, HD shocks
- Firm ride Suspension
- Front and rear 19.5 x 6 argent steel wheels
- Dual rear wheels
- * **Rear DANA 130 rigid axle leaf spring suspension with anti-roll bar, HD shocks**
- Hydraulic power-assist re-circulating ball Steering
- LT225/70SR19.5 GBSW AS front and rear tires

Body Exterior

- 4 doors
- Conventional right rear passenger
- * **Turn signal indicator in mirrors**
- Black bumpers
- Trailer harness
- Front and rear 19.5 x 6 wheels
- Conventional left rear passenger
- * **Driver and passenger power remote heated, manual folding door mirrors with turn signal indicator**
- Black door mirrors
- * **Side steps**
- Clearcoat paint
- 2 front tow hook(s)

Convenience

- Manual air conditioning with air filter
- * **Power windows**

Prices and content availability as shown are subject to change and should be treated as estimates only. Actual base vehicle, package and option pricing may vary from this estimate because of special local pricing, availability or pricing adjustments not reflected in the dealer's computer system. See salesperson for the most current information.

Prepared for: Matthew Porras

Yucaipa Valley Water District

Prepared by: David Pratt

10/13/2021

Transwest Truck Center | 10150 Cherry Ave. Fontana California | 923355222

**2022 F-550 Chassis 4x4 SD Crew Cab 203" WB DRW XL (W5H)**

Price Level: 240 | Quote ID: YVWDcrane1

Selected Equip & Specs (cont'd)

- * **Driver and passenger 1-touch up**
- * **Remote power door locks with 2 stage unlock and illuminated entry**
- Manual telescopic steering wheel
- FordPass Connect 4G internet access
- Wireless phone connectivity
- 2 1st row LCD monitors
- Passenger visor mirror
- * **Driver and passenger door bins**
- Upfitter switches
- * **Driver and passenger 1-touch down**
- Manual tilt steering wheel
- Day-night rearview mirror
- 911 Assist emergency SOS
- AppLink smart device integration
- Front and rear cupholders
- Full overhead console
- * **Rear door bins**

Seats and Trim

- Seating capacity of 6
- 4-way driver seat adjustment
- 4-way passenger seat adjustment
- 60-40 folding rear split-bench seat
- Front 40-20-40 split-bench seat
- Manual driver lumbar support
- Centre front armrest with storage

Entertainment Features

- AM/FM stereo radio
- Steering wheel mounted radio controls
- Streaming audio
- SYNC external memory control
- 4 speakers
- Fixed antenna

Lighting, Visibility and Instrumentation

- Halogen aero-composite headlights
- Auto on/off headlights
- Light tinted windows
- Tachometer
- Compass
- * **Camera(s) - rear**
- Trip odometer
- Delay-off headlights
- Variable intermittent front windshield wipers
- Front and rear reading lights
- Oil pressure gauge
- Outside temperature display
- Trip computer

Safety and Security

- 4-wheel ABS brakes
- 4-wheel disc brakes
- Dual front impact airbag supplemental restraint system
- Safety Canopy System curtain 1st and 2nd row overhead airbag supplemental restraint system
- * **Power remote door locks with 2 stage unlock and panic alarm**
- * **MyKey restricted driving mode**
- Brake assist
- Driveline traction control
- Dual seat mounted side impact airbag supplemental restraint system
- * **Remote activated perimeter/approach lighting**
- * **Security system with SecuriLock immobilizer**
- Manually adjustable front head restraints

Prices and content availability as shown are subject to change and should be treated as estimates only. Actual base vehicle, package and option pricing may vary from this estimate because of special local pricing, availability or pricing adjustments not reflected in the dealer's computer system. See salesperson for the most current information.

Prepared for: Matthew Porras

Yucaipa Valley Water District
 Prepared by: David Pratt
 10/13/2021



Transwest Truck Center | 10150 Cherry Ave. Fontana California | 923355222

2022 F-550 Chassis 4x4 SD Crew Cab 203" WB DRW XL (W5H)

Price Level: 240 | Quote ID: YVWDcrane1

Selected Equip & Specs (cont'd)

- 3 manually adjustable rear head restraints

Dimensions

General Weights

* Curb	7,738 lbs.	* GVWR	19,500 lbs.
* Payload	11,900 lbs.		

Front Weights

Front GAWR	6,000 lbs.	* Front curb weight	4,470 lbs.
Front axle capacity	7,000 lbs.	Front spring rating	6,000 lbs.
Front tire/wheel capacity	7,500 lbs.		

Rear Weights

* Rear GAWR	14,706 lbs.	* Rear curb weight	3,268 lbs.
* Rear axle capacity	14,706 lbs.	* Rear spring rating	15,000 lbs.
Rear tire/wheel capacity	15,000 lbs.		

Trailer Type

Harness	Yes	* Brake controller	Yes
Trailer sway control	Yes		

General Trailering

5th-wheel towing capacity	19300 lbs.	Gooseneck towing capacity	19300 lbs.
Towing capacity	18340 lbs.	GCWR	28000 lbs.

Fuel Tank type

Capacity	40 gal.
----------------	---------

Off Road

Min ground clearance	8 "
----------------------------	-----

Interior cargo

Cargo volume	52.1 cu.ft.	Maximum cargo volume	52.1 cu.ft.
--------------------	-------------	----------------------------	-------------

Rear Frame

Height loaded	29 "	Height unloaded	34 "
---------------------	------	-----------------------	------

Powertrain

Engine Type

Block material	Iron	Cylinders	V-8
Head material	Aluminum	Ignition	Spark
Injection	Sequential MPI	Liters	7.3L
Orientation	Longitudinal	Recommended fuel	Regular unleaded
Valves per cylinder	2	Valvetrain	OHV

Prices and content availability as shown are subject to change and should be treated as estimates only. Actual base vehicle, package and option pricing may vary from this estimate because of special local pricing, availability or pricing adjustments not reflected in the dealer's computer system. See salesperson for the most current information.

Prepared for: Matthew Porras

Yucaipa Valley Water District

Prepared by: David Pratt

10/13/2021

Transwest Truck Center | 10150 Cherry Ave. Fontana California | 923355222



2022 F-550 Chassis 4x4 SD Crew Cab 203" WB DRW XL (W5H)

Price Level: 240 | Quote ID: YVWDcrane1

Selected Equip & Specs (cont'd)

Variable valve control	DEVCT		
<i>Engine Spec</i>			
Bore	4.21"	Compression ratio	10.5:1
Displacement	445 cu.in.	Stroke	3.98"
<i>Engine Power</i>			
SAEJ1349 AUG2004 compliant	Yes	Output	350 HP @ 3,900 RPM
Torque	468 ft.-lb @ 3,900 RPM		
<i>Alternator</i>			
* Type	Dual	* Amps	397
<i>Battery</i>			
Amp hours	78	Cold cranking amps	750
Run down protection	Yes	* Type	Dual
<i>Transmission</i>			
Electronic control	Yes	Lock-up	Yes
Overdrive	Yes	Speed	10
Type	Automatic		
<i>Transmission Gear Ratios</i>			
1st	4.696	2nd	2.985
3rd	2.146	4th	1.769
5th	1.52	6th	1.275
7th	1	8th	0.854
9th	0.689	10th	0.616
Reverse Gear ratios	4.866		
<i>Transmission Extras</i>			
Driver selectable mode	Yes	Sequential shift control	SelectShift
Oil cooler	Regular duty		
<i>Drive Type</i>			
4wd type	Part-time	Type	Four-wheel
<i>Drive Feature</i>			
* Limited slip differential	Mechanical	Traction control	Driveline
Locking hub control	Auto	Transfer case shift	Electronic
<i>Drive Axle</i>			
Ratio	4.88		
<i>Exhaust</i>			
Material	Stainless steel	System type	Single

Prices and content availability as shown are subject to change and should be treated as estimates only. Actual base vehicle, package and option pricing may vary from this estimate because of special local pricing, availability or pricing adjustments not reflected in the dealer's computer system. See salesperson for the most current information.

Prepared for: Matthew Porras

Yucaipa Valley Water District

Prepared by: David Pratt

10/13/2021

Transwest Truck Center | 10150 Cherry Ave. Fontana California | 923355222



2022 F-550 Chassis 4x4 SD Crew Cab 203" WB DRW XL (W5H)

Price Level: 240 | Quote ID: YVWDcrane1

Selected Equip & Specs (cont'd)

Emissions

CARB Federal

Fuel Economy

Fuel type Gasoline

Driveability

Brakes

ABS 4-wheel
 Type 4-wheel disc
 ABS channels 3
 Vented discs Front and rear

Brake Assistance

Brake assist Yes

Suspension Control

Ride Firm

Front Suspension

Independence Mono-beam non-independent
 Anti-roll bar Regular

Front Spring

Type Coil
 Grade Regular

Front Shocks

Type HD

Rear Suspension

* Independence **DANA 130 rigid axle**
 Type Leaf
 Anti-roll bar Regular

Rear Spring

Type Leaf
 Grade HD

Rear Shocks

Type HD

Steering

Activation Hydraulic power-assist
 Type Re-circulating ball

Steering Specs

of wheels 2

Exterior

Front Wheels

Diameter 19.5" Width 6.00"

Prices and content availability as shown are subject to change and should be treated as estimates only. Actual base vehicle, package and option pricing may vary from this estimate because of special local pricing, availability or pricing adjustments not reflected in the dealer's computer system. See salesperson for the most current information.

Prepared for: Matthew Porras

Yucaipa Valley Water District

Prepared by: David Pratt

10/13/2021

Transwest Truck Center | 10150 Cherry Ave. Fontana California | 923355222



2022 F-550 Chassis 4x4 SD Crew Cab 203" WB DRW XL (W5H)

Price Level: 240 | Quote ID: YVWDcrane1

Selected Equip & Specs (cont'd)

Rear Wheels

Diameter	19.5"	Width	6.00"
Dual	Yes		

Front and Rear Wheels

Appearance	Argent	Material	Steel
------------	--------	----------	-------

Front Tires

Aspect	70	Diameter	19.5"
Sidewalls	BSW	Speed	S
Tread	AS	Type	LT
Width	225mm	LT load rating	G
RPM	647		

Rear Tires

Aspect	70	Diameter	19.5"
Sidewalls	BSW	Speed	S
Tread	AS	Type	LT
Width	225mm	LT load rating	G
RPM	647		

Wheels

Front track	74.8"	Rear track	74.0"
Turning radius	28.6'	Wheelbase	203.0"
Rear tire outside width	93.9"		

Body Features

Front splash guards	Yes	* Skid plate(s)	1
Body material	Aluminum	Side impact beams	Yes
* Side steps	Yes	Front tow hook(s)	2

Body Doors

Door count	4	Left rear passenger	Conventional
Right rear passenger	Conventional		

Exterior Dimensions

Length	289.2"	Body width	80.0"
Body height	81.7"	Cab to axle	84.0"
Axle to end of frame	47.2"	Frame section modulus	12.7cu.in.
Frame yield strength (psi)	50000.0	Frame rail width	34.2"
Front bumper to Front axle	38.3"	Cab to end of frame	131.2"
Front bumper to back of cab	158.1"		

Safety

Prices and content availability as shown are subject to change and should be treated as estimates only. Actual base vehicle, package and option pricing may vary from this estimate because of special local pricing, availability or pricing adjustments not reflected in the dealer's computer system. See salesperson for the most current information.

Prepared for: Matthew Porras

Yucaipa Valley Water District

Prepared by: David Pratt

10/13/2021

Transwest Truck Center | 10150 Cherry Ave. Fontana California | 923355222



2022 F-550 Chassis 4x4 SD Crew Cab 203" WB DRW XL (W5H)

Price Level: 240 | Quote ID: YVWDcrane1

Selected Equip & Specs (cont'd)

Airbags

Driver front-impact	Yes	Driver side-impact	Seat mounted
Overhead Safety Canopy System curtain 1st and 2nd row		Passenger front-impact	Yes
Passenger side-impact	Seat mounted		

Seatbelt

Height adjustable

Front

Security

* Immobilizer	SecuriLock	* Panic alarm	Yes
* Restricted driving mode	MyKey		

Seating

Passenger Capacity

Capacity

6

Front Seats

Split	40-20-40	Type	Split-bench
-------------	----------	------------	-------------

Driver Seat

Fore/aft	Manual	Reclining	Manual
Way direction control	4	Lumbar support	Manual

Passenger seat

Fore/aft	Manual	Reclining	Manual
Way direction control	4		

Front Head Restraint

Control	Manual	Type	Adjustable
---------------	--------	------------	------------

Front Armrest

Centre	Yes	Storage	Yes
--------------	-----	---------------	-----

Rear Seats

Descriptor	Split-bench	Facing	Front
Folding	60-40	Folding position	Fold-up cushion
Type	Fixed		

Rear Head Restraints

Control	Manual	Type	Adjustable
Number	3		

Front Seat Trim

Material	Vinyl	Back material	Vinyl
----------------	-------	---------------------	-------

Prices and content availability as shown are subject to change and should be treated as estimates only. Actual base vehicle, package and option pricing may vary from this estimate because of special local pricing, availability or pricing adjustments not reflected in the dealer's computer system. See salesperson for the most current information.

Prepared for: Matthew Porras

Yucaipa Valley Water District

Prepared by: David Pratt

10/13/2021

Transwest Truck Center | 10150 Cherry Ave. Fontana California | 923355222



2022 F-550 Chassis 4x4 SD Crew Cab 203" WB DRW XL (W5H)

Price Level: 240 | Quote ID: YVWDcrane1

Selected Equip & Specs (cont'd)

Rear Seat Trim Group

Material Vinyl Back material Carpet

Convenience

AC And Heat Type

Air conditioning Manual Air filter Yes
 Underseat ducts Yes

Audio System

Radio AM/FM stereo Radio grade Regular
 Seek-scan Yes External memory control SYNC

Audio Speakers

Speaker type Regular Speakers 4

Audio Controls

Steering wheel controls Yes Voice activation Yes
 Streaming audio Bluetooth yes

Audio Antenna

Type Fixed

LCD Monitors

1st row 2 Primary monitor size (inches) 4.2

Convenience Features

* Retained accessory power Yes 12V DC power outlet 3
 Emergency SOS 911 Assist Wireless phone connectivity Bluetooth
 * Back-up alarm Yes Smart device integration App link
 Upfitter switches Yes

Door Lock Activation

* Type Power with 2 stage unlock * Remote Keyfob (all doors)
 * Integrated key/remote Yes

Door Locks Extra FOB Controls

Remote engine start Smart device only

Instrumentation Type

Appearance Analog

Instrumentation Gauges

Tachometer Yes Oil pressure Yes
 Engine temperature Yes Transmission fluid temp Yes
 Engine hour meter Yes

Prices and content availability as shown are subject to change and should be treated as estimates only. Actual base vehicle, package and option pricing may vary from this estimate because of special local pricing, availability or pricing adjustments not reflected in the dealer's computer system. See salesperson for the most current information.

Prepared for: Matthew Porras

Yucaipa Valley Water District

Prepared by: David Pratt

10/13/2021

Transwest Truck Center | 10150 Cherry Ave. Fontana California | 923355222



2022 F-550 Chassis 4x4 SD Crew Cab 203" WB DRW XL (W5H)

Price Level: 240 | Quote ID: YVWDcrane1

Selected Equip & Specs (cont'd)

Instrumentation Warnings

Oil pressure	Yes	Engine temperature	Yes
Battery	Yes	Lights on	Yes
Key	Yes	Low fuel	Yes
Door ajar	Yes	Service interval	Yes
Brake fluid	Yes		

Instrumentation Displays

Clock	In-radio display	Compass	Yes
Exterior temp	Yes	Systems monitor	Yes
* Camera(s) - rear	Yes		

Instrumentation Feature

Trip computer	Yes	Trip odometer	Yes
---------------------	-----	---------------------	-----

Steering Wheel Type

Material	Urethane	Tilting	Manual
Telescoping	Manual		

Front Side Windows

* Window 1st row activation **Power**

Windows Rear Side

* 2nd row activation **Power**

Window Features

* 1-touch down	Driver and passenger	* 1-touch up	Driver and passenger
Tinted	Light		

Front Windshield

Wiper

Variable intermittent

Rear Windshield

Window

Fixed

Interior

Passenger Visor

Mirror

Yes

Rear View Mirror

Day-night

Yes

Headliner

Coverage	Full	Material	Cloth
----------------	------	----------------	-------

Prices and content availability as shown are subject to change and should be treated as estimates only. Actual base vehicle, package and option pricing may vary from this estimate because of special local pricing, availability or pricing adjustments not reflected in the dealer's computer system. See salesperson for the most current information.

Prepared for: Matthew Porras

Yucaipa Valley Water District

Prepared by: David Pratt

10/13/2021

Transwest Truck Center | 10150 Cherry Ave. Fontana California | 923355222



2022 F-550 Chassis 4x4 SD Crew Cab 203" WB DRW XL (W5H)

Price Level: 240 | Quote ID: YVWDcrane1

Selected Equip & Specs (cont'd)

Floor Trim

Coverage Full Covering Vinyl/rubber

Trim Feature

Gear shifter material Urethane Interior accents Chrome

Lighting

Dome light type Fade Front reading Yes
 * **Illuminated entry** **Yes** Rear reading Yes
 Variable IP lighting Yes

Overhead Console Storage

Storage Yes Type Full

Storage

* **Driver door bin** **Yes** Front Beverage holder(s) Yes
 Glove box Locking * **Passenger door bin** **Yes**
 * **Seatback storage pockets** **2** Illuminated Yes
 Rear yes Yes Instrument panel Covered bin
 Dashboard Yes * **Rear door bins** **Yes**

Legroom

Front 43.9" Rear 43.6"

Headroom

Front 40.8" Rear 40.4"

Hip Room

Front 62.5" Rear 64.7"

Shoulder Room

Front 66.7" Rear 65.9"

Interior Volume

Passenger volume 131.7 cu.ft.

Prices and content availability as shown are subject to change and should be treated as estimates only. Actual base vehicle, package and option pricing may vary from this estimate because of special local pricing, availability or pricing adjustments not reflected in the dealer's computer system. See salesperson for the most current information.

Prepared for: Matthew Porras

Yucaipa Valley Water District

Prepared by: David Pratt

10/13/2021

Transwest Truck Center | 10150 Cherry Ave. Fontana California | 923355222



2022 F-550 Chassis 4x4 SD Crew Cab 203" WB DRW XL (W5H)

Price Level: 240 | Quote ID: YVWDcrane1

Warranty

Standard Warranty

Basic

Distance 36,000 miles Months 36 months

Powertrain

Distance 60,000 miles Months 60 months

Corrosion Perforation

Distance Unlimited miles Months 60 months

Roadside Assistance

Distance 60,000 miles Months 60 months

Prices and content availability as shown are subject to change and should be treated as estimates only. Actual base vehicle, package and option pricing may vary from this estimate because of special local pricing, availability or pricing adjustments not reflected in the dealer's computer system. See salesperson for the most current information.

Prepared for: Matthew Porras

Yucaipa Valley Water District

Prepared by: David Pratt

10/13/2021

Transwest Truck Center | 10150 Cherry Ave. Fontana California | 923355222



2022 F-550 Chassis 4x4 SD Crew Cab 203" WB DRW XL (W5H)

Price Level: 240 | Quote ID: YVWDcrane1

Vehicle Dimension and Performance Summary

Performance predictions in this report represent an estimate of vehicle performance based on standard operating conditions. Variations in customer equipment, load configuration, ambient conditions, and/or operator driving techniques can cause significant variations in vehicle performance. These values are not representative of results that may be shown in actual dynamometer tests. This report should therefore be used as a guide for comparative vehicle performance.

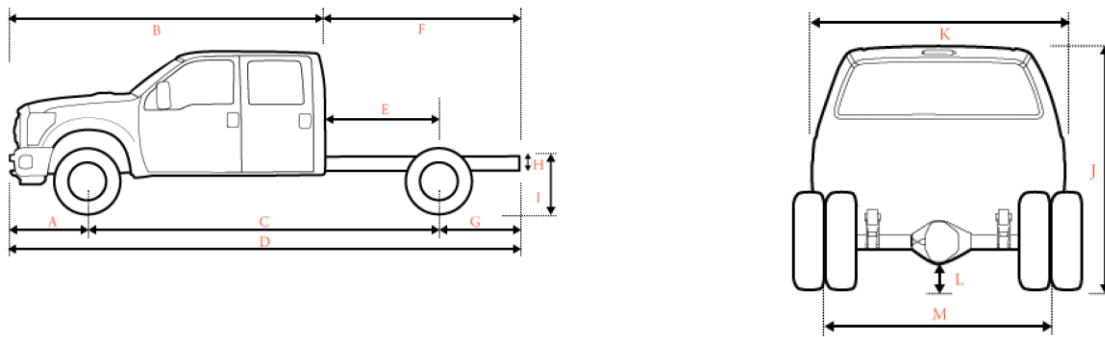

Dimensions

A	Front of Bumper to Front Axle	38.30 in.
B	Front Bumper to Back of Cab (BBC)	158.10 in.
C	Wheelbase (WB)	203.00 in.
D	Overall Length (OAL)	289.20 in.
E	Back of Cab to Rear Axle (CA)	84.00 in.
F	Back of Cab to End of Frame	131.20 in.
G	Rear Axle to End of Frame (AF)	47.20 in.
H	Frame Section Height	N/A
I	Rear Frame Height Unloaded	34.30 in.
I	Rear Frame Height Loaded	28.60 in.
J	Cab Height	81.70 in.
K	Body Width	80.00 in.
L	Maximum Ground Clearance	N/A
L	Minimum Ground Clearance	8.20 in.
M	Front Tread	74.80 in.
M	Rear Tread	74.00 in.

Prices and content availability as shown are subject to change and should be treated as estimates only. Actual base vehicle, package and option pricing may vary from this estimate because of special local pricing, availability or pricing adjustments not reflected in the dealer's computer system. See salesperson for the most current information.

Prepared for: Matthew Porras

Yucaipa Valley Water District

Prepared by: David Pratt

10/13/2021

Transwest Truck Center | 10150 Cherry Ave. Fontana California | 923355222



2022 F-550 Chassis 4x4 SD Crew Cab 203" WB DRW XL (W5H)

Price Level: 240 | Quote ID: YVWDcrane1

Vehicle Dimension and Performance Summary (cont'd)

Body Specs

Truck body style:	Utility
Cab to body gap:	3.00 in.
Body length:	10.68 ft
Body tare weight:	3,600 lbs
Body width:	96 in.
Body height from ground:	99 in.
Body Centre gravity (from front):	64.10 in.

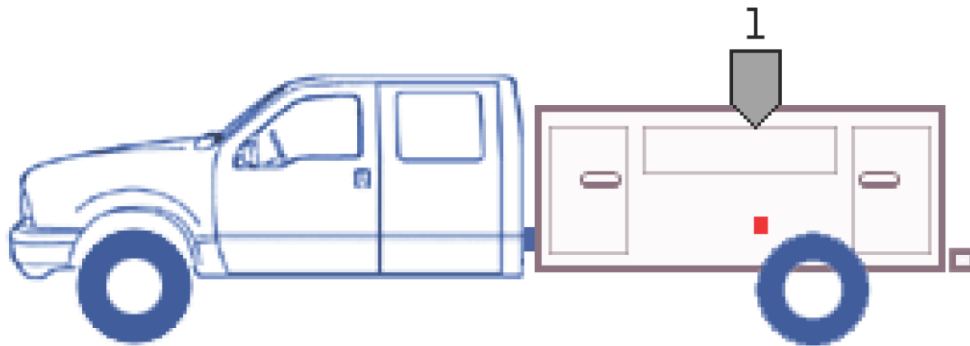

Prices and content availability as shown are subject to change and should be treated as estimates only. Actual base vehicle, package and option pricing may vary from this estimate because of special local pricing, availability or pricing adjustments not reflected in the dealer's computer system. See salesperson for the most current information.

Prepared for: Matthew Porras

Yucaipa Valley Water District

Prepared by: David Pratt

10/13/2021

Transwest Truck Center | 10150 Cherry Ave. Fontana California | 923355222



2022 F-550 Chassis 4x4 SD Crew Cab 203" WB DRW XL (W5H)

Price Level: 240 | Quote ID: YVWDcrane1

Vehicle Dimension and Performance Summary (cont'd)

Weight

Licensing

GVWR does not exceed 26,000 lbs and may not require a Commercial Driver's License (CDL). Contact your local state commercial driver licensing office for specifics on what your state requires.

GVW	Front Axle	Rear Axle	Totals
Chassis	4,470 lbs	3,268 lbs	7,738 lbs
Body	301 lbs	3,299 lbs	3,600 lbs
Occupants Weight	600 lbs	300 lbs	900 lbs
1 Max Payload - (Max Payload)	629 lbs	6,633 lbs	7,262 lbs
TOTAL	6,000 lbs	13,500 lbs	19,500 lbs

Ratings	Front Axle	Rear Axle	GVWR
GAWR	6,000 lbs	14,706 lbs	19,500 lbs
Wheels/Tires	7,500 lbs	15,000 lbs	
Suspension	6,000 lbs	15,000 lbs	
Axle	7,000 lbs	14,706 lbs	
Legal Axle Limit	0 lbs	0 lbs	

Start, Grade and Speed

Start	Ratio	Desired	Calculated
Start grade capability in 1st gear	4.70	15.00 %	33.26 %
Start grade capability in reverse	4.87	15.00 %	34.46 %

Grade	Ratio	Desired	Calculated
Maximum grade in 8th gear	0.85	3.00 %	6.05 %
Maximum grade in 9th gear	0.69	3.00 %	4.88 %
Maximum grade in 10th gear	0.62	3.00 %	4.36 %

Speed	Desired	Calculated
Top Speed (level grade)	75 mph	120 mph
<i>To meet your requirement you need a maximum axle ratio of 9.39</i>		
Top Speed on 3.0% grade	55 mph	
<i>To meet your requirement you need a maximum of 122 hp</i>		
Cruise Speed	60 mph	80 mph
Engine RPM at desired cruise speed		1,945 rpm

Prices and content availability as shown are subject to change and should be treated as estimates only. Actual base vehicle, package and option pricing may vary from this estimate because of special local pricing, availability or pricing adjustments not reflected in the dealer's computer system. See salesperson for the most current information.

Prepared for: Matthew Porras

Yucaipa Valley Water District

Prepared by: David Pratt

10/13/2021

Transwest Truck Center | 10150 Cherry Ave. Fontana California | 923355222



2022 F-550 Chassis 4x4 SD Crew Cab 203" WB DRW XL (W5H)

Price Level: 240 | Quote ID: YVWDcrane1

Vehicle Dimension and Performance Summary (cont'd)

Variables in Use

Rear axle ratio:	4.88/4.88	Peak Torque RPM:	3,900 rpm
Tire size:	225/70R19.5 (647 rev/mile)	Frontal Area:	40.39 Sq.Ft.
Gross Vehicle Weight (GVW):	19,500 lbs	Cruising RPM	2,600 rpm
Clutch engagement torque:	234 ft.lbs.	Worst road surface	Typical Highway
Torque conversion ratio:	2.00	Final Drive Ratio:	0.62
Peak engine torque:	468 ft.lbs.	Drag Coefficient	0.80
Engine Power:	350 hp @ 3,900 rpm		

Shift Chart

Shift Chart displays mathematical geared speed.
 Diesel engines use Governed RPM for shift points.
 Gas engines use Peak Torque RPM for shift points.

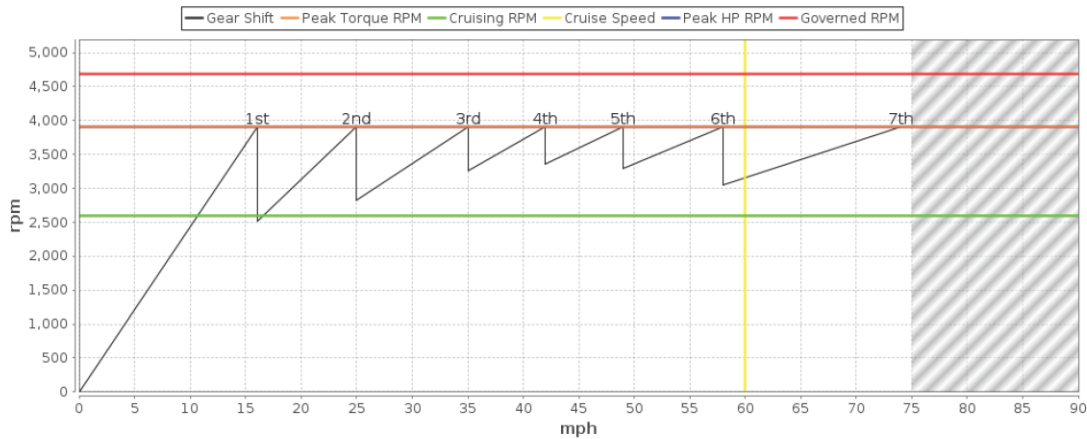

Prices and content availability as shown are subject to change and should be treated as estimates only. Actual base vehicle, package and option pricing may vary from this estimate because of special local pricing, availability or pricing adjustments not reflected in the dealer's computer system. See salesperson for the most current information.

Prepared for: Matthew Porras

Yucaipa Valley Water District

Prepared by: David Pratt

10/13/2021

Transwest Truck Center | 10150 Cherry Ave. Fontana California | 923355222



2022 F-550 Chassis 4x4 SD Crew Cab 203" WB DRW XL (W5H)

Price Level: 240 | Quote ID: YVWDcrane1

Vehicle Dimension and Performance Summary (cont'd)

Turning Radius

Turning Radius 28.60 ft

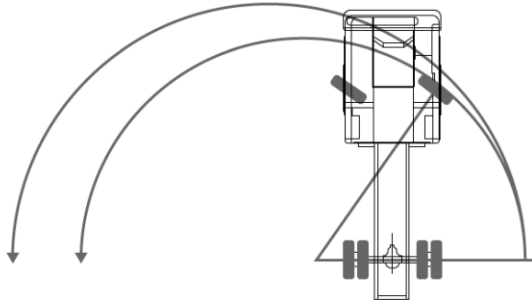

Prices and content availability as shown are subject to change and should be treated as estimates only. Actual base vehicle, package and option pricing may vary from this estimate because of special local pricing, availability or pricing adjustments not reflected in the dealer's computer system. See salesperson for the most current information.



SALES (909) 770-5170
 PARTS (909) 770-5180
 SERVICE (909) 770-5620
 10150 Cherry Ave
 Fontana CA 92335

Buyers Order

Deal#: DE-87560-1
 Opp#: 2021-135282
 Date: 10/21/2021

WWW.TRANS-WEST.COM
TransWest Truck Center is a division of velocity vehicle group

Contact: David Pratt - Mobile: 951-515-4352 - Email: dpratt@trans-west.com

Bill To: PROS-140375
 YUCAIPA VALLEY WATER DIST
 12770 2ND ST
 YUCAIPA CA 92399 County: San Bernardino
 Phone: (909) 797-5117
 mporras@yvw.d.us

Ship To:

Unit#:	Stock#:	New 2022 FORD F600	Price:	\$75,997.00
VIN:		GVW: 22000	Color: White	
To Be Delivered On or About: 04/21/2022			Unit Price:	\$75,997.00

Sub Total	\$75,997.00
Doc Fee	\$85.00
CA Tire Recycle Fee	\$10.50
Sales Tax (7.750%)	\$5,896.36
Total Vehicle Sale Price	\$81,988.86
Net Total	\$81,988.86

Lienholder: None

Dump Truck.

ONLY THOSE ITEMS AND SERVICES SPECIFICALLY WRITTEN ON THIS ORDER ARE INCLUDED IN THE STATED PRICE.
 ANY OTHER AGREEMENTS, UNLESS IN WRITING, ARE NOT BINDING ON SELLER.

The numbered pages of this Order comprise the entire agreement affecting this purchase and no other agreement or understanding of any nature concerning this purchase has been made or entered into, or will be recognized. I hereby certify that no credit has been extended to me for the purchase of this motor vehicle except as appears in writing on the face of this agreement. I have read and understand the final page of this agreement and agree to it as a part of this order the same as if it were printed above my signature. I certify that I am of legal age, or older, that I have legal capacity and authority to execute this agreement on behalf of my company, and hereby acknowledge receipt of a copy of this order.

YUCAIPA VALLEY WATER DIST
(Purchaser's Name)

David Pratt
(Salesperson Name)

X
(Purchaser's Signature)

(Approved By)

Date

Date

1. TRADE-IN(S). Purchaser shall deliver trade-in(s) in the same condition as at the time of inspection and appraisal by Seller reasonable wear and tear excepted, except as disclosed in the Agreement. Purchase represents that each truck shall be free and clear of all liens and encumbrances and warrants that the trade-in(s) are that type and condition described in this Agreement, including any attachments hereto.

2. TERMS OF PAYMENT. Unless otherwise agreed, net payment shall be due on delivery. Late payments shall bear interest at the rate of 18% per annum, or the maximum permitted by law, whichever is less. If acceptance of delivery is delayed by Purchaser, payment shall become due on the date when Seller is prepared to deliver. If the financial condition of Purchaser at any time does not, in the judgment of Seller, justify continuance of the work to be performed by Seller hereunder on the terms of payment as agreed upon, Seller may suspend such work, or postpone delivery, and require such assurances of Purchaser's performance as Seller deems adequate, including payment in advance, or Seller may cancel this order and shall receive reimbursement for its reasonable and proper cancellation charges. In the event of bankruptcy or insolvency of Purchaser, voluntary or involuntary, Seller shall be entitled to cancel any order then outstanding at any time and seek reimbursement for its reasonable and proper cancellation charges.

3. CANCELLATION. Purchaser may cancel this order only if Seller is able to cancel said order with the manufacturer, and only upon written notice. Upon cancellation or failure to accept delivery, Purchaser shall pay Seller reasonable cancellation changes and expenses, not to be less than Seller's out-of-pocket expenses including carrying costs.

4. SALES AND OTHER TAXES. Unless otherwise specified herein, Seller's price does not include federal excise, sales, use, or other taxes. Consequently, in addition to the price specified herein, the amount of any other excise, sales, use or other taxes applicable to the sale or use of the trucks purchased hereunder shall be paid by Purchaser, or in lieu thereof Purchaser shall provide Seller with a tax exemption certificate acceptable to the taxing authorities. Purchaser agrees that all taxes related to this transaction, whether arising at the time of the transaction or in the future, are Purchaser's responsibility and further agrees to promptly pay any such taxes.

5. DELIVERY. All trucks furnished hereunder shall be delivered to Purchaser at the Seller's dealership location or other location as designated in this Agreement. Unless otherwise provided, delivery will be made via carriers and routes designated by manufacturer with freight charges to be included in the purchase price. Delivery dates are approximate and are based upon receipt of all necessary information from Purchaser. Seller shall not be liable for delays in delivery or manufacturing, or other causes beyond Seller's control.

6. TECHNICAL CHANGES. Purchaser acknowledges that the manufacturer and Seller reserve the right to change the specifications of the truck(s) at any time without obligation to make such changes in other trucks previously delivered to Purchaser. In addition, manufacturer and Seller reserve the right to make design changes and substitution of materials subsequent to the receipt of the order which, in manufacturers or Seller's opinion are necessary to improve the truck. Purchaser agrees to accept any such changes as fulfillment of Seller's obligations under this order.

7. REQUIRED EQUIPMENT. This order shall be deemed to include, whether or not specified herein, all equipment or accessories required by the National Highway Traffic Safety Act or other regulations in effect at the time of order of receipt. It is agreed that any additional or different equipment not specified which is required at the time of delivery to meet the foregoing Act or other regulations will be added and the costs shall be paid by Purchaser. Purchaser understands that certain safety equipment is available that is not legally required and is available at Purchasers request for an additional fee.

8. TITLE AND REMEDIES. Until full payment by Purchaser of all amounts due hereunder, Seller reserves the title to all equipment furnished hereunder. If Purchaser defaults in payment or performance hereunder or becomes subject to insolvency, receivership, or bankruptcy proceedings, or makes an assignment for the benefit of creditors, or without the consent of Seller voluntarily or involuntarily sells, transfers, leases, or permits any lien or attachment on the equipment delivered hereunder, Seller may treat all amounts then or thereafter owing hereunder by Purchaser as immediately due and payable (subject only to credits required by law) and Seller may repossess said equipment by any means available by law and shall enjoy any and all other remedies of a secured creditor under the Uniform Commercial Code. Purchaser shall execute and deliver to Seller such financing statements and other documents, as Seller may deem appropriate to evidence, perfect, and protect the priority of its security interest in the truck(s) subject to this order.

9. GENERAL. Any assignment by Purchaser of this order or any rights hereunder, without written consent of Seller, shall be void. Clerical errors in this order may be automatically corrected by giving written notice thereof to Purchaser by a duly authorized representative of Seller. No waiver, alteration, or modification of any of the provisions hereof shall be binding unless and until in writing and signed by a duly authorized representative of Seller. To the extent not covered by other terms herein, including terms of warranty and limitation of liability, etc., the provisions of the Uniform Commercial Code shall govern this sale.

10. IMPORT TARIFFS: Purchaser acknowledges that any import tariffs imposed by the government are the sole responsibility of the Purchaser and will result in an increase in the Seller's price equal to the amount of the obligatory tariff.

This Agreement (including by reference the provisions set out in manufacturer's standard warranty or warranties) shall constitute the entire agreement between Purchaser and Seller, and no understandings or obligations not expressly set forth herein or in manufacturer's standard warranty or warranties are binding upon Purchaser or Seller.

ALL WARRANTIES, IF ANY, BY A MANUFACTURER OR SUPPLIER OTHER THAN SELLER ARE THEIRS, NOT SELLER'S, AND ONLY SUCH MANUFACTURER OR OTHER SUPPLIER SHALL BE LIABLE FOR PERFORMANCE UNDER SUCH WARRANTIES. SELLER HEREBY DISCLAIMS ALL WARRANTIES, EXPRESS OR IMPLIED, INCLUDING ANY IMPLIED WARRANTIES OF MERCHANTABILITY OR FITNESS FOR A PARTICULAR PURPOSE.

Accepted and Agreed by: _____ (Company Name) _____ (Date)

Signature's Name and Title: _____ (Please Print Name and Title. Must be an Officer of the company Authorized to approve capital purchases.) X _____ (Signature)

Oct 21 2021 3:22PM

Skaug Truck Body Works

1404 First Street
 San Fernando, CA 91340
 (818) 365-9123

Estimate

Date	Estimate #
10/18/2021	3666

Name / Address
Trans West Truck Center 10150 Cherry Ave. Fontana, CA 92335

				Project
Item	Description	Qty	Cost	Total
Resale	9' 2-3 cubic yard dump body 12" high sides, 18" high tail gate SR4016 Rugby dump hoist with PTO driven pump 3- coal shutes in tailgate 1/4 cab shield Spreader apron 2- Work lights on cab shield 2- strobe lights on rear 2- strobe lights on front grill 2- strobe lights on sides 1- 18 x 18 x 36 jockey box frame mounted on passenger side 1- cone holder under bed behind cab driver side 3" receiver hitch 7-way trailer plug Mount backup camera Painted black and installed For: Yucaipa Water District			
			Subtotal	
			Sales Tax (10.25%)	
			Total	

Prepared for: Matthew Porras, Yucaipa Valley Water District

12770 Second Street

Yucaipa, CA 92399

Office: 909-790-3300

Email: mporras@yvwd.us

Dump Truck Spec.

2022 F-600 Chassis 4x4 SD Regular Cab 145" WB DRW XL (F6L)

Price Level: 240



Client Proposal

Prepared by:

David Pratt

Office: 909-770-5195

Quote ID: YVWDDump

Date: 10/20/2021



Transwest Truck Center | 10150 Cherry Ave., Fontana, California, 923355222

Office: 909-770-5620

Prepared for: Matthew Porras

Yucaipa Valley Water District

Prepared by: David Pratt

10/20/2021

Transwest Truck Center | 10150 Cherry Ave. Fontana California | 923355222



2022 F-600 Chassis 4x4 SD Regular Cab 145" WB DRW XL (F6L)

Price Level: 240 | Quote ID: YVWDDump

As Configured Vehicle

Description

Base Vehicle

Base Vehicle Price (F6L)

Packages

Order Code 680A

Includes:

- Engine: 7.3L 2V DEVCT NA PFI V8 Gas
- Transmission: TorqShift 10-Speed Automatic
- 10R140 with neutral idle and selectable drive modes: normal, tow/haul, eco, deep sand/snow and slippery.
- Transmission Power Take-Off Provision
- Includes mobile and stationary PTO modes.
- Limited Slip w/4.88 Axle Ratio
- GVWR: 22,000 lbs Payload Package
- Tires: 245/70Rx19.5G BSW A/P
- Spare may not be the same as road tire.
- Wheels: 19.5" x 6.75" Argent Painted Steel
- HD Vinyl 40/20/40 Split Bench Seat
- Includes center armrest, cupholder, storage and driver's side manual lumbar.
- Radio: AM/FM Stereo w/MP3 Player
- Includes 4 speakers.
- SYNC Communications & Entertainment System
- Includes enhanced voice recognition, 911 Assist, 4.2" LCD center stack screen, AppLink, 1 smart-charging USB port and steering wheel audio controls.

Powertrain

Engine: 7.3L 2V DEVCT NA PFI V8 Gas

Transmission: TorqShift 10-Speed Automatic

10R140 with neutral idle and selectable drive modes: normal, tow/haul, eco, deep sand/snow and slippery.

Includes:

- Transmission Power Take-Off Provision
- Includes mobile and stationary PTO modes.

Limited Slip w/4.88 Axle Ratio

GVWR: 22,000 lbs Payload Package

Wheels & Tires

Tires: 245/70Rx19.5G BSW A/P

Spare may not be the same as road tire.

Wheels: 19.5" x 6.75" Argent Painted Steel

Seats & Seat Trim

HD Vinyl 40/20/40 Split Bench Seat

Includes center armrest, cupholder, storage and driver's side manual lumbar.

Other Options

Prices and content availability as shown are subject to change and should be treated as estimates only. Actual base vehicle, package and option pricing may vary from this estimate because of special local pricing, availability or pricing adjustments not reflected in the dealer's computer system. See salesperson for the most current information.

Prepared for: Matthew Porras

Yucaipa Valley Water District

Prepared by: David Pratt

10/20/2021

Transwest Truck Center | 10150 Cherry Ave. Fontana California | 923355222

**2022 F-600 Chassis 4x4 SD Regular Cab 145" WB DRW XL (F6L)**

Price Level: 240 | Quote ID: YVWDDump

As Configured Vehicle (cont'd)**Description**

Monotone Paint Application

145" Wheelbase

Radio: AM/FM Stereo w/MP3 Player

*Includes 4 speakers.**Includes:**- SYNC Communications & Entertainment System**Includes enhanced voice recognition, 911 Assist, 4.2" LCD center stack screen, AppLink, 1 smart-charging USB port and steering wheel audio controls.***Power Equipment Group***Deletes passenger side lock cylinder. Includes upgraded door-trim panel.**Includes:**- Accessory Delay**- Advanced Security Pack**Includes SecurLock Passive Anti-Theft System (PATS) and inclination/intrusion sensors.**- Folding Trailer Tow Mirrors w/Power Heated Glass**Includes manual telescoping, heated convex spotter mirror and integrated clearance lamps/turn signals.**- MyKey**Includes owner controls feature.**- Power Front Side Windows**Includes 1-touch up/down driver/passenger window.**- Power Locks**- Remote Keyless Entry*

Transfer Case Skid Plates

Dual 78 AH Battery

397 Amp Alternators

Utility Lighting System

Includes LED side-mirror spotlights.

Trailer Brake Controller

Includes smart trailer tow connector. Verified to be compatible with electronic actuated drum brakes only.

Platform Running Boards

Rear View Camera & Prep Kit

Pre-installed content includes cab wiring and frame wiring to the rear most cross member. Upfitters kit includes camera with mounting bracket, 20' jumper wire and camera mounting/aiming instructions.

Exterior Backup Alarm (Pre-Installed)

Emissions

50-State Emissions System

Interior Color

Medium Earth Gray

Prices and content availability as shown are subject to change and should be treated as estimates only. Actual base vehicle, package and option pricing may vary from this estimate because of special local pricing, availability or pricing adjustments not reflected in the dealer's computer system. See salesperson for the most current information.

Prepared for: Matthew Porras

Yucaipa Valley Water District

Prepared by: David Pratt

10/20/2021

Transwest Truck Center | 10150 Cherry Ave. Fontana California | 923355222



2022 F-600 Chassis 4x4 SD Regular Cab 145" WB DRW XL (F6L)

Price Level: 240 | Quote ID: YVWDDump

As Configured Vehicle (cont'd)

Description

Exterior Color

Oxford White

Prices and content availability as shown are subject to change and should be treated as estimates only. Actual base vehicle, package and option pricing may vary from this estimate because of special local pricing, availability or pricing adjustments not reflected in the dealer's computer system. See salesperson for the most current information.

Prepared for: Matthew Porras

Yucaipa Valley Water District

Prepared by: David Pratt

10/20/2021

Transwest Truck Center | 10150 Cherry Ave. Fontana California | 923355222

**2022 F-600 Chassis 4x4 SD Regular Cab 145" WB DRW XL (F6L)**

Price Level: 240 | Quote ID: YVWDDump

Selected Equip & Specs

Dimensions

- Exterior length: 230.7"
- Exterior width: 80.0"
- Front track: 74.8"
- Turning radius: 21.2'
- Front legroom: 43.9"
- Front hiproom: 62.5"
- Passenger volume: 64.6cu.ft.
- Maximum cargo volume: 11.6cu.ft.
- Cab to axle: 60.0"
- Wheelbase: 145.0"
- Rear track: 74.0"
- Rear tire outside width: 93.9"
- Front headroom: 40.8"
- Front shoulder room: 66.7"
- Cargo volume: 11.6cu.ft.

Powertrain

- 350hp 7.3L OHV 16 valve V-8 engine with DEVCT variable valve control, SMPI
- federal
- Part-time
- Fuel Economy Cty: N/A
- Transmission PTO provision
- Recommended fuel : regular unleaded
- TorqShift 10 speed automatic transmission with overdrive
- Limited slip differential
- Fuel Economy Highway: N/A

Suspension/Handling

- Front Mono-beam non-independent suspension with anti-roll bar, HD shocks
- Firm ride Suspension
- Front and rear 19.5 x 6.75 argent steel wheels
- Dual rear wheels
- Rear DANA M300 rigid axle leaf spring suspension with anti-roll bar, HD shocks
- Hydraulic power-assist re-circulating ball Steering
- LT245/70SR19.5 GBSW AS front and rear tires

Body Exterior

- 2 doors
- * **Turn signal indicator in mirrors**
- Black bumpers
- Trailer harness
- Front and rear 19.5 x 6.75 wheels
- * **Driver and passenger power remote heated, manual folding door mirrors with turn signal indicator**
- Black door mirrors
- * **Side steps**
- Clearcoat paint
- 2 front tow hook(s)

Convenience

- Manual air conditioning with air filter
- * **Driver and passenger 1-touch up**
- * **Remote power door locks with 2 stage unlock and illuminated entry**
- Manual telescopic steering wheel
- * **Power front windows**
- * **Driver and passenger 1-touch down**
- Manual tilt steering wheel
- Day-night rearview mirror

Prices and content availability as shown are subject to change and should be treated as estimates only. Actual base vehicle, package and option pricing may vary from this estimate because of special local pricing, availability or pricing adjustments not reflected in the dealer's computer system. See salesperson for the most current information.

Prepared for: Matthew Porras

Yucaipa Valley Water District

Prepared by: David Pratt

10/20/2021

Transwest Truck Center | 10150 Cherry Ave. Fontana California | 923355222



2022 F-600 Chassis 4x4 SD Regular Cab 145" WB DRW XL (F6L)

Price Level: 240 | Quote ID: YVWDDump

Selected Equip & Specs (cont'd)

- FordPass Connect 4G internet access
- Wireless phone connectivity
- 2 1st row LCD monitors
- Passenger visor mirror
- Upfitter switches
- 911 Assist emergency SOS
- AppLink smart device integration
- Front cupholders
- * **Driver and passenger door bins**

Seats and Trim

- Seating capacity of 3
- 4-way driver seat adjustment
- 4-way passenger seat adjustment
- Front 40-20-40 split-bench seat
- Manual driver lumbar support
- Centre front armrest with storage

Entertainment Features

- AM/FM stereo radio
- Steering wheel mounted radio controls
- Streaming audio
- SYNC external memory control
- 4 speakers
- Fixed antenna

Lighting, Visibility and Instrumentation

- Halogen aero-composite headlights
- Auto on/off headlights
- Light tinted windows
- Tachometer
- Compass
- * **Camera(s) - rear**
- Trip odometer
- Delay-off headlights
- Variable intermittent front windshield wipers
- Front reading lights
- Oil pressure gauge
- Outside temperature display
- Trip computer

Safety and Security

- 4-wheel ABS brakes
- 4-wheel disc brakes
- Dual front impact airbag supplemental restraint system with passenger cancel
- Safety Canopy System curtain 1st row overhead airbag supplemental restraint system
- * **Power remote door locks with 2 stage unlock and panic alarm**
- * **MyKey restricted driving mode**
- Brake assist
- Driveline traction control
- Dual seat mounted side impact airbag supplemental restraint system
- * **Remote activated perimeter/approach lighting**
- * **Security system with SecuriLock immobilizer**
- Manually adjustable front head restraints

Dimensions

General Weights

* Curb	7,333 lbs.	GVWR	22,000 lbs.
Payload	14,780 lbs.		

Prices and content availability as shown are subject to change and should be treated as estimates only. Actual base vehicle, package and option pricing may vary from this estimate because of special local pricing, availability or pricing adjustments not reflected in the dealer's computer system. See salesperson for the most current information.

Prepared for: Matthew Porras

Yucaipa Valley Water District

Prepared by: David Pratt

10/20/2021

Transwest Truck Center | 10150 Cherry Ave. Fontana California | 923355222



2022 F-600 Chassis 4x4 SD Regular Cab 145" WB DRW XL (F6L)

Price Level: 240 | Quote ID: YVWDDump

Selected Equip & Specs (cont'd)

Front Weights

Front GAWR	7,500 lbs.	* Front curb weight	4,178 lbs.
Front axle capacity	7,500 lbs.	Front spring rating	7,500 lbs.

Rear Weights

Rear GAWR	15,500 lbs.	* Rear curb weight	3,155 lbs.
Rear axle capacity	15,500 lbs.	Rear spring rating	15,500 lbs.

Trailer Type

Harness	Yes	* Brake controller	Yes
Trailer sway control	Yes		

General Trailering

5th-wheel towing capacity	21900 lbs.	Gooseneck towing capacity	21900 lbs.
Towing capacity	18500 lbs.	GCWR	30000 lbs.

Fuel Tank type

Capacity	40 gal.
----------------	---------

Interior cargo

Cargo volume	11.6 cu.ft.	Maximum cargo volume	11.6 cu.ft.
--------------------	-------------	----------------------------	-------------

Rear Frame

Height loaded	29 "	Height unloaded	35 "
---------------------	------	-----------------------	------

Powertrain

Engine Type

Block material	Iron	Cylinders	V-8
Head material	Aluminum	Ignition	Spark
Injection	Sequential MPI	Liters	7.3L
Orientation	Longitudinal	Recommended fuel	Regular unleaded
Valves per cylinder	2	Valvetrain	OHV
Variable valve control	DEVCT		

Engine Spec

Bore	4.21"	Compression ratio	10.5:1
Displacement	445 cu.in.	Stroke	3.98"

Engine Power

SAEJ1349 AUG2004 compliant	Yes	Output	350 HP @ 3,900 RPM
Torque	468 ft.-lb @ 3,900 RPM		

Alternator

* Type	Dual	* Amps	397
---------------------	-------------	---------------------	------------

Prices and content availability as shown are subject to change and should be treated as estimates only. Actual base vehicle, package and option pricing may vary from this estimate because of special local pricing, availability or pricing adjustments not reflected in the dealer's computer system. See salesperson for the most current information.

Prepared for: Matthew Porras

Yucaipa Valley Water District

Prepared by: David Pratt

10/20/2021

Transwest Truck Center | 10150 Cherry Ave. Fontana California | 923355222



2022 F-600 Chassis 4x4 SD Regular Cab 145" WB DRW XL (F6L)

Price Level: 240 | Quote ID: YVWDDump

Selected Equip & Specs (cont'd)

Battery

Amp hours	78	Cold cranking amps	750
Run down protection	Yes	*Type	Dual

Transmission

Electronic control	Yes	Lock-up	Yes
Overdrive	Yes	Speed	10
Type	Automatic		

Transmission Gear Ratios

1st	4.696	2nd	2.985
3rd	2.146	4th	1.769
5th	1.52	6th	1.275
7th	1	8th	0.854
9th	0.689	10th	0.616
Reverse Gear ratios	4.866		

Transmission Extras

Driver selectable mode	Yes	Sequential shift control	SelectShift
Oil cooler	Regular duty	PTO provision	Yes

Drive Type

4wd type	Part-time	Type	Four-wheel
----------	-----------	------	------------

Drive Feature

Limited slip differential	Mechanical	Traction control	Driveline
Power take-off provision	Yes	Locking hub control	Auto
Transfer case shift	Electronic		

Drive Axle

Ratio	4.88
-------	------

Exhaust

Material	Stainless steel	System type	Single
----------	-----------------	-------------	--------

Emissions

CARB	Federal
------	---------

Fuel Economy

Fuel type	Gasoline
-----------	----------

Driveability

Brakes

ABS	4-wheel	ABS channels	3
Type	4-wheel disc	Vented discs	Front and rear

Prices and content availability as shown are subject to change and should be treated as estimates only. Actual base vehicle, package and option pricing may vary from this estimate because of special local pricing, availability or pricing adjustments not reflected in the dealer's computer system. See salesperson for the most current information.

Prepared for: Matthew Porras

Yucaipa Valley Water District

Prepared by: David Pratt

10/20/2021

Transwest Truck Center | 10150 Cherry Ave. Fontana California | 923355222



2022 F-600 Chassis 4x4 SD Regular Cab 145" WB DRW XL (F6L)

Price Level: 240 | Quote ID: YVWDDump

Selected Equip & Specs (cont'd)

Brake Assistance

Brake assist Yes

Suspension Control

Ride Firm

Front Suspension

Independence ... Mono-beam non-independent Anti-roll bar Regular

Front Spring

Type Coil Grade HD

Front Shocks

Type HD

Rear Suspension

Independence DANA M300 rigid axle Type Leaf
Anti-roll bar Regular

Rear Spring

Type Leaf Grade HD

Rear Shocks

Type HD

Steering

Activation Hydraulic power-assist Type Re-circulating ball

Steering Specs

of wheels 2

Exterior

Front Wheels

Diameter 19.5" Width 6.75"

Rear Wheels

Diameter 19.5" Width 6.75"
Dual Yes

Front and Rear Wheels

Appearance Argent Material Steel

Front Tires

Aspect 70 Diameter 19.5"
Sidewalls BSW Speed S
Tread AS Type LT
Width 245mm LT load rating G

Prices and content availability as shown are subject to change and should be treated as estimates only. Actual base vehicle, package and option pricing may vary from this estimate because of special local pricing, availability or pricing adjustments not reflected in the dealer's computer system. See salesperson for the most current information.

Prepared for: Matthew Porras

Yucaipa Valley Water District

Prepared by: David Pratt

10/20/2021

Transwest Truck Center | 10150 Cherry Ave. Fontana California | 923355222



2022 F-600 Chassis 4x4 SD Regular Cab 145" WB DRW XL (F6L)

Price Level: 240 | Quote ID: YVWDDump

Selected Equip & Specs (cont'd)

Rear Tires

Aspect	70	Diameter	19.5"
Sidewalls	BSW	Speed	S
Tread	AS	Type	LT
Width	245mm	LT load rating	G

Wheels

Front track	74.8"	Rear track	74.0"
Turning radius	21.2'	Wheelbase	145.0"
Rear tire outside width	93.9"		

Body Features

Front splash guards	Yes	* Skid plate(s)	1
Body material	Aluminum	Side impact beams	Yes
* Side steps	Yes	Front tow hook(s)	2

Body Doors

Door count	2
------------------	---

Exterior Dimensions

Length	230.7"	Body width	80.0"
Cab to axle	60.0"	Axle to end of frame	47.2"
Frame section modulus	12.7cu.in.	Frame yield strength (psi)	50000.0
Frame rail width	34.2"	Front bumper to Front axle	38.3"
Cab to end of frame	107.2"	Front bumper to back of cab	123.7"

Safety

Airbags

Driver front-impact	Yes	Driver side-impact	Seat mounted
Overhead	Safety Canopy System curtain 1st row	Passenger front-impact	Cancellable
Passenger side-impact	Seat mounted		

Seatbelt

Height adjustable	Front
-------------------------	-------

Security

* Immobilizer	SecuriLock	* Panic alarm	Yes
* Restricted driving mode	MyKey		

Seating

Passenger Capacity

Capacity	3
----------------	---

Prices and content availability as shown are subject to change and should be treated as estimates only. Actual base vehicle, package and option pricing may vary from this estimate because of special local pricing, availability or pricing adjustments not reflected in the dealer's computer system. See salesperson for the most current information.

Prepared for: Matthew Porras

Yucaipa Valley Water District

Prepared by: David Pratt

10/20/2021

Transwest Truck Center | 10150 Cherry Ave. Fontana California | 923355222



2022 F-600 Chassis 4x4 SD Regular Cab 145" WB DRW XL (F6L)

Price Level: 240 | Quote ID: YVWDDump

Selected Equip & Specs (cont'd)

Front Seats

Split 40-20-40 Type Split-bench

Driver Seat

Fore/aft Manual Reclining Manual
Way direction control 4 Lumbar support Manual

Passenger seat

Fore/aft Manual Reclining Manual
Way direction control 4

Front Head Restraint

Control Manual Type Adjustable

Front Armrest

Centre Yes Storage Yes

Front Seat Trim

Material Vinyl Back material Vinyl

Convenience

AC And Heat Type

Air conditioning Manual Air filter Yes

Audio System

Radio AM/FM stereo Radio grade Regular
Seek-scan Yes External memory control SYNC

Audio Speakers

Speaker type Regular Speakers 4

Audio Controls

Steering wheel controls Yes Voice activation Yes
Streaming audio Bluetooth yes

Audio Antenna

Type Fixed

LCD Monitors

1st row 2 Primary monitor size (inches) 4.2

Convenience Features

* **Retained accessory power** **Yes** 12V DC power outlet 3
Emergency SOS 911 Assist Wireless phone connectivity Bluetooth
* **Back-up alarm** **Yes** Smart device integration App link
Upfitter switches Yes

Prices and content availability as shown are subject to change and should be treated as estimates only. Actual base vehicle, package and option pricing may vary from this estimate because of special local pricing, availability or pricing adjustments not reflected in the dealer's computer system. See salesperson for the most current information.

Prepared for: Matthew Porras

Yucaipa Valley Water District

Prepared by: David Pratt

10/20/2021

Transwest Truck Center | 10150 Cherry Ave. Fontana California | 923355222



2022 F-600 Chassis 4x4 SD Regular Cab 145" WB DRW XL (F6L)

Price Level: 240 | Quote ID: YVWDDump

Selected Equip & Specs (cont'd)

Door Lock Activation

* Type **Power with 2 stage unlock** * Remote **Keyfob (all doors)**
 * Integrated key/remote **Yes**

Door Locks Extra FOB Controls

Remote engine start **Smart device only**

Instrumentation Type

Appearance **Analog**

Instrumentation Gauges

Tachometer **Yes** Oil pressure **Yes**
 Engine temperature **Yes** Transmission fluid temp **Yes**
 Engine hour meter **Yes**

Instrumentation Warnings

Oil pressure **Yes** Engine temperature **Yes**
 Battery **Yes** Lights on **Yes**
 Key **Yes** Low fuel **Yes**
 Door ajar **Yes** Service interval **Yes**
 Brake fluid **Yes**

Instrumentation Displays

Clock **In-radio display** Compass **Yes**
 Exterior temp **Yes** Systems monitor **Yes**
 * Camera(s) - rear **Yes**

Instrumentation Feature

Trip computer **Yes** Trip odometer **Yes**

Steering Wheel Type

Material **Urethane** Tilting **Manual**
 Telescoping **Manual**

Front Side Windows

* Window 1st row activation **Power**

Window Features

* 1-touch down **Driver and passenger** * 1-touch up **Driver and passenger**
 Tinted **Light**

Front Windshield

Wiper **Variable intermittent**

Rear Windshield

Window **Fixed**

Prices and content availability as shown are subject to change and should be treated as estimates only. Actual base vehicle, package and option pricing may vary from this estimate because of special local pricing, availability or pricing adjustments not reflected in the dealer's computer system. See salesperson for the most current information.

Prepared for: Matthew Porras

Yucaipa Valley Water District

Prepared by: David Pratt

10/20/2021

Transwest Truck Center | 10150 Cherry Ave. Fontana California | 923355222



2022 F-600 Chassis 4x4 SD Regular Cab 145" WB DRW XL (F6L)

Price Level: 240 | Quote ID: YVWDDump

Selected Equip & Specs (cont'd)

Interior

Passenger Visor

Mirror Yes

Rear View Mirror

Day-night Yes

Headliner

Coverage Full Material Cloth

Floor Trim

Coverage Full Covering Vinyl/rubber

Trim Feature

Gear shifter material Urethane Interior accents Chrome

Lighting

Dome light type Fade Front reading Yes

* **Illuminated entry** **Yes** Variable IP lighting Yes

Storage

* **Driver door bin** **Yes** Front Beverage holder(s) Yes

Glove box Locking * **Passenger door bin** **Yes**

Illuminated Yes Instrument panel Covered bin

Dashboard Yes

Legroom

Front 43.9"

Headroom

Front 40.8"

Hip Room

Front 62.5"

Shoulder Room

Front 66.7"

Interior Volume

Passenger volume 64.6 cu.ft.

Prices and content availability as shown are subject to change and should be treated as estimates only. Actual base vehicle, package and option pricing may vary from this estimate because of special local pricing, availability or pricing adjustments not reflected in the dealer's computer system. See salesperson for the most current information.

Prepared for: Matthew Porras

Yucaipa Valley Water District

Prepared by: David Pratt

10/20/2021

Transwest Truck Center | 10150 Cherry Ave. Fontana California | 923355222



2022 F-600 Chassis 4x4 SD Regular Cab 145" WB DRW XL (F6L)

Price Level: 240 | Quote ID: YVWDDump

Warranty

Standard Warranty

Basic

Distance 36,000 miles Months 36 months

Powertrain

Distance 60,000 miles Months 60 months

Corrosion Perforation

Distance Unlimited miles Months 60 months

Roadside Assistance

Distance 60,000 miles Months 60 months

Prices and content availability as shown are subject to change and should be treated as estimates only. Actual base vehicle, package and option pricing may vary from this estimate because of special local pricing, availability or pricing adjustments not reflected in the dealer's computer system. See salesperson for the most current information.



SALES (909) 770-5170
 PARTS (909) 770-5180
 SERVICE (909) 770-5620
 10150 Cherry Ave
 Fontana CA 92335

Buyers Order

Deal#: DE-87560-2
 Opp#: 2021-135282
 Date: 10/21/2021

WWW.TRANS-WEST.COM
TransWest Truck Center is a division of velocity vehicle group

Contact: David Pratt - Mobile: 951-515-4352 - Email: dpratt@trans-west.com

Bill To: PROS-140375
 YUCAIPA VALLEY WATER DIST
 12770 2ND ST
 YUCAIPA CA 92399 County: San Bernardino
 Phone: (909) 797-5117
 mporras@yvwd.us

Ship To:

Unit#:	Stock#:	New 2022 FORD F600	Price:	\$64,198.00
VIN:		GVW: 22000	Color: White	
To Be Delivered On or About: 04/21/2022			Unit Price:	\$64,198.00

Sub Total	\$64,198.00
Doc Fee	\$85.00
CA Tire Recycle Fee	\$10.50
Sales Tax (7.750%)	<u>\$4,981.93</u>
Total Vehicle Sale Price	<u>\$69,275.43</u>
Net Total	\$69,275.43

Lienholder: None
 Valve truck.

ONLY THOSE ITEMS AND SERVICES SPECIFICALLY WRITTEN ON THIS ORDER ARE INCLUDED IN THE STATED PRICE.
 ANY OTHER AGREEMENTS, UNLESS IN WRITING, ARE NOT BINDING ON SELLER.

The numbered pages of this Order comprise the entire agreement affecting this purchase and no other agreement or understanding of any nature concerning this purchase has been made or entered into, or will be recognized. I hereby certify that no credit has been extended to me for the purchase of this motor vehicle except as appears in writing on the face of this agreement. I have read and understand the final page of this agreement and agree to it as a part of this order the same as if it were printed above my signature. I certify that I am of legal age, or older, that I have legal capacity and authority to execute this agreement on behalf of my company, and hereby acknowledge receipt of a copy of this order.

YUCAIPA VALLEY WATER DIST
(Purchaser's Name)

David Pratt
(Salesperson Name)

X
(Purchaser's Signature)

(Approved By)

Date

Date

1. **TRADE-IN(S).** Purchaser shall deliver trade-in(s) in the same condition as at the time of inspection and appraisal by Seller reasonable wear and tear excepted, except as disclosed in the Agreement. Purchase represents that each truck shall be free and clear of all liens and encumbrances and warrants that the trade-in(s) are that type and condition described in this Agreement, including any attachments hereto.
2. **TERMS OF PAYMENT.** Unless otherwise agreed, net payment shall be due on delivery. Late payments shall bear interest at the rate of 18% per annum, or the maximum permitted by law, whichever is less. If acceptance of delivery is delayed by Purchaser, payment shall become due on the date when Seller is prepared to deliver. If the financial condition of Purchaser at any time does not, in the judgment of Seller, justify continuance of the work to be performed by Seller hereunder on the terms of payment as agreed upon, Seller may suspend such work, or postpone delivery, and require such assurances of Purchaser's performance as Seller deems adequate, including payment in advance, or Seller may cancel this order and shall receive reimbursement for its reasonable and proper cancellation charges. In the event of bankruptcy or insolvency of Purchaser, voluntary or involuntary, Seller shall be entitled to cancel any order then outstanding at any time and seek reimbursement for its reasonable and proper cancellation charges.
3. **CANCELLATION.** Purchaser may cancel this order only if Seller is able to cancel said order with the manufacturer, and only upon written notice. Upon cancellation or failure to accept delivery, Purchaser shall pay Seller reasonable cancellation charges and expenses, not to be less than Seller's out-of-pocket expenses including carrying costs.
4. **SALES AND OTHER TAXES.** Unless otherwise specified herein, Seller's price does not include federal excise, sales, use, or other taxes. Consequently, in addition to the price specified herein, the amount of any other excise, sales, use or other taxes applicable to the sale or use of the trucks purchased hereunder shall be paid by Purchaser, or in lieu thereof Purchaser shall provide Seller with a tax exemption certificate acceptable to the taxing authorities. Purchaser agrees that all taxes related to this transaction, whether arising at the time of the transaction or in the future, are Purchaser's responsibility and further agrees to promptly pay any such taxes.
5. **DELIVERY.** All trucks furnished hereunder shall be delivered to Purchaser at the Seller's dealership location or other location as designated in this Agreement. Unless otherwise provided, delivery will be made via carriers and routes designated by manufacturer with freight charges to be included in the purchase price. Delivery dates are approximate and are based upon receipt of all necessary information from Purchaser. Seller shall not be liable for delays in delivery or manufacturing, or other causes beyond Seller's control.
6. **TECHNICAL CHANGES.** Purchaser acknowledges that the manufacturer and Seller reserve the right to change the specifications of the truck(s) at any time without obligation to make such changes in other trucks previously delivered to Purchaser. In addition, manufacturer and Seller reserve the right to make design changes and substitution of materials subsequent to the receipt of the order which, in manufacturers or Seller's opinion are necessary to improve the truck. Purchaser agrees to accept any such changes as fulfillment of Seller's obligations under this order.
7. **REQUIRED EQUIPMENT.** This order shall be deemed to include, whether or not specified herein, all equipment or accessories required by the National Highway Traffic Safety Act or other regulations in effect at the time of order of receipt. It is agreed that any additional or different equipment not specified which is required at the time of delivery to meet the foregoing Act or other regulations will be added and the costs shall be paid by Purchaser. Purchaser understands that certain safety equipment is available that is not legally required and is available at Purchasers request for an additional fee.
8. **TITLE AND REMEDIES.** Until full payment by Purchaser of all amounts due hereunder, Seller reserves the title to all equipment furnished hereunder. If Purchaser defaults in payment or performance hereunder or becomes subject to insolvency, receivership, or bankruptcy proceedings, or makes an assignment for the benefit of creditors, or without the consent of Seller voluntarily or involuntarily sells, transfers, leases, or permits any lien or attachment on the equipment delivered hereunder, Seller may treat all amounts then or thereafter owing hereunder by Purchaser as immediately due and payable (subject only to credits required by law) and Seller may repossess said equipment by any means available by law and shall enjoy any and all other remedies of a secured creditor under the Uniform Commercial Code. Purchaser shall execute and deliver to Seller such financing statements and other documents, as Seller may deem appropriate to evidence, perfect, and protect the priority of its security interest in the truck(s) subject to this order.
9. **GENERAL.** Any assignment by Purchaser of this order or any rights hereunder, without written consent of Seller, shall be void. Clerical errors in this order may be automatically corrected by giving written notice thereof to Purchaser by a duly authorized representative of Seller. No waiver, alteration, or modification of any of the provisions hereof shall be binding unless and until in writing and signed by a duly authorized representative of Seller. To the extent not covered by other terms herein, including terms of warranty and limitation of liability, etc., the provisions of the Uniform Commercial Code shall govern this sale.
10. **IMPORT TARIFFS:** Purchaser acknowledges that any import tariffs imposed by the government are the sole responsibility of the Purchaser and will result in an increase in the Seller's price equal to the amount of the obligatory tariff.

This Agreement (including by reference the provisions set out in manufacturer's standard warranty or warranties) shall constitute the entire agreement between Purchaser and Seller, and no understandings or obligations not expressly set forth herein or in manufacturer's standard warranty or warranties are binding upon Purchaser or Seller.

ALL WARRANTIES, IF ANY, BY A MANUFACTURER OR SUPPLIER OTHER THAN SELLER ARE THEIRS, NOT SELLER'S, AND ONLY SUCH MANUFACTURER OR OTHER SUPPLIER SHALL BE LIABLE FOR PERFORMANCE UNDER SUCH WARRANTIES. SELLER HEREBY DISCLAIMS ALL WARRANTIES, EXPRESS OR IMPLIED, INCLUDING ANY IMPLIED WARRANTIES OF MERCHANTABILITY OR FITNESS FOR A PARTICULAR PURPOSE.

Accepted and Agreed by: _____ (Company Name) _____ (Date)

Signor's Name and Title: _____ X _____ (Signature)
 (Please Print Name and Title. Must be an Officer of the company Authorized to approve capital purchases.)

Oct 21 2021 3:19PM

Skaug Truck Body Works

1404 First Street
 San Fernando, CA 91340
 (818) 365-9123

Estimate

Date	Estimate #
10/18/2021	3665

Name / Address
Trans West Truck Center 10150 Cherry Ave. Fontana, CA 92335

				Project
Item	Description	Qty	Cost	Total
Resale	8 x 12 platform body Pockets in rail Steel diaplate floor 1- 18 x 18 x 60 jockey box passenger side 1- 18 x 18 x 40 jockey box driver side 1- cone holder next to box on driver side Work lights on head board 2- strobe lights on rear 2- strobe lights on front grill 2- strobe lights on sides 3" receiver hitch 7-way trailer plug Mount backup camera Painted white and installed For: Yucaipa Water District			
			Subtotal	
			Sales Tax (10.25%)	
			Total	

Prepared for: Matthew Porras, Yucaipa Valley Water District

12770 Second Street

Yucaipa, CA 92399

Office: 909-790-3300

Email: mporras@yvwd.us

Valve Truck

2022 F-600 Chassis 4x4 SD Regular Cab 169" WB DRW XL (F6L)

Price Level: 240



Client Proposal

Prepared by:

David Pratt

Office: 909-770-5195

Quote ID: YVWDValve

Date: 10/20/2021



Transwest Truck Center | 10150 Cherry Ave., Fontana, California, 923355222

Office: 909-770-5620

Prepared for: Matthew Porras

Yucaipa Valley Water District

Prepared by: David Pratt

10/20/2021

Transwest Truck Center | 10150 Cherry Ave. Fontana California | 923355222

**2022 F-600 Chassis 4x4 SD Regular Cab 169" WB DRW XL (F6L)**

Price Level: 240 | Quote ID: YVWDValve

As Configured Vehicle**Description****Base Vehicle**

Base Vehicle Price (F6L)

Packages

Order Code 680A

Includes:

- Engine: 7.3L 2V DEVCT NA PFI V8 Gas
- Transmission: TorqShift 10-Speed Automatic
- 10R140 with neutral idle and selectable drive modes: normal, tow/haul, eco, deep sand/snow and slippery.
- Transmission Power Take-Off Provision
- Includes mobile and stationary PTO modes.
- Limited Slip w/4.88 Axle Ratio
- GVWR: 22,000 lbs Payload Package
- Tires: 245/70Rx19.5G BSW A/P
- Spare may not be the same as road tire.
- Wheels: 19.5" x 6.75" Argent Painted Steel
- HD Vinyl 40/20/40 Split Bench Seat
- Includes center armrest, cupholder, storage and driver's side manual lumbar.
- Radio: AM/FM Stereo w/MP3 Player
- Includes 4 speakers.
- SYNC Communications & Entertainment System
- Includes enhanced voice recognition, 911 Assist, 4.2" LCD center stack screen, AppLink, 1 smart-charging USB port and steering wheel audio controls.

Powertrain

Engine: 7.3L 2V DEVCT NA PFI V8 Gas

Transmission: TorqShift 10-Speed Automatic

10R140 with neutral idle and selectable drive modes: normal, tow/haul, eco, deep sand/snow and slippery.

Includes:

- Transmission Power Take-Off Provision
- Includes mobile and stationary PTO modes.

Limited Slip w/4.88 Axle Ratio

GVWR: 22,000 lbs Payload Package

Wheels & Tires

Tires: 245/70Rx19.5G BSW A/P

Spare may not be the same as road tire.

Wheels: 19.5" x 6.75" Argent Painted Steel

Seats & Seat Trim

HD Vinyl 40/20/40 Split Bench Seat

Includes center armrest, cupholder, storage and driver's side manual lumbar.

Other Options

Prices and content availability as shown are subject to change and should be treated as estimates only. Actual base vehicle, package and option pricing may vary from this estimate because of special local pricing, availability or pricing adjustments not reflected in the dealer's computer system. See salesperson for the most current information.

Prepared for: Matthew Porras

Yucaipa Valley Water District

Prepared by: David Pratt

10/20/2021

Transwest Truck Center | 10150 Cherry Ave. Fontana California | 923355222

**2022 F-600 Chassis 4x4 SD Regular Cab 169" WB DRW XL (F6L)**

Price Level: 240 | Quote ID: YVWDValve

As Configured Vehicle (cont'd)**Description**

Monotone Paint Application

169" Wheelbase

Radio: AM/FM Stereo w/MP3 Player

*Includes 4 speakers.**Includes:**- SYNC Communications & Entertainment System**Includes enhanced voice recognition, 911 Assist, 4.2" LCD center stack screen, AppLink, 1 smart-charging USB port and steering wheel audio controls.*

Power Equipment Group

*Deletes passenger side lock cylinder. Includes upgraded door-trim panel.**Includes:**- Accessory Delay**- Advanced Security Pack**Includes SecurLock Passive Anti-Theft System (PATS) and inclination/intrusion sensors.**- Folding Trailer Tow Mirrors w/Power Heated Glass**Includes manual telescoping, heated convex spotter mirror and integrated clearance lamps/turn signals.**- MyKey**Includes owner controls feature.**- Power Front Side Windows**Includes 1-touch up/down driver/passenger window.**- Power Locks**- Remote Keyless Entry*

Transfer Case Skid Plates

Dual 78 AH Battery

397 Amp Alternators

Utility Lighting System

Includes LED side-mirror spotlights.

Trailer Brake Controller

Includes smart trailer tow connector. Verified to be compatible with electronic actuated drum brakes only.

Platform Running Boards

Rear View Camera & Prep Kit

Pre-installed content includes cab wiring and frame wiring to the rear most cross member. Upfitters kit includes camera with mounting bracket, 20' jumper wire and camera mounting/aiming instructions.

Exterior Backup Alarm (Pre-Installed)

Emissions

50-State Emissions System

Interior Color

Medium Earth Gray

Prices and content availability as shown are subject to change and should be treated as estimates only. Actual base vehicle, package and option pricing may vary from this estimate because of special local pricing, availability or pricing adjustments not reflected in the dealer's computer system. See salesperson for the most current information.

Prepared for: Matthew Porras

Yucaipa Valley Water District

Prepared by: David Pratt

10/20/2021

Transwest Truck Center | 10150 Cherry Ave. Fontana California | 923355222



2022 F-600 Chassis 4x4 SD Regular Cab 169" WB DRW XL (F6L)

Price Level: 240 | Quote ID: YVWDValve

As Configured Vehicle (cont'd)

Description

Exterior Color

Oxford White

Prices and content availability as shown are subject to change and should be treated as estimates only. Actual base vehicle, package and option pricing may vary from this estimate because of special local pricing, availability or pricing adjustments not reflected in the dealer's computer system. See salesperson for the most current information.

Prepared for: Matthew Porras

Yucaipa Valley Water District

Prepared by: David Pratt

10/20/2021

Transwest Truck Center | 10150 Cherry Ave. Fontana California | 923355222



2022 F-600 Chassis 4x4 SD Regular Cab 169" WB DRW XL (F6L)

Price Level: 240 | Quote ID: YVWDValve

Selected Equip & Specs

Dimensions

- Exterior length: 254.8"
- Exterior width: 80.0"
- Front track: 74.8"
- Turning radius: 24.2'
- Front legroom: 43.9"
- Front hiproom: 62.5"
- Passenger volume: 64.6cu.ft.
- Maximum cargo volume: 11.6cu.ft.
- Cab to axle: 84.0"
- Wheelbase: 169.0"
- Rear track: 74.0"
- Rear tire outside width: 93.9"
- Front headroom: 40.8"
- Front shoulder room: 66.7"
- Cargo volume: 11.6cu.ft.

Powertrain

- 350hp 7.3L OHV 16 valve V-8 engine with DEVCT variable valve control, SMPI
- federal
- Part-time
- Fuel Economy Cty: N/A
- Transmission PTO provision
- Recommended fuel : regular unleaded
- TorqShift 10 speed automatic transmission with overdrive
- Limited slip differential
- Fuel Economy Highway: N/A

Suspension/Handling

- Front Mono-beam non-independent suspension with anti-roll bar, HD shocks
- Firm ride Suspension
- Front and rear 19.5 x 6.75 argent steel wheels
- Dual rear wheels
- Rear DANA M300 rigid axle leaf spring suspension with anti-roll bar, HD shocks
- Hydraulic power-assist re-circulating ball Steering
- LT245/70SR19.5 GBSW AS front and rear tires

Body Exterior

- 2 doors
- * **Turn signal indicator in mirrors**
- Black bumpers
- Trailer harness
- Front and rear 19.5 x 6.75 wheels
- * **Driver and passenger power remote heated, manual folding door mirrors with turn signal indicator**
- Black door mirrors
- * **Side steps**
- Clearcoat paint
- 2 front tow hook(s)

Convenience

- Manual air conditioning with air filter
- * **Driver and passenger 1-touch up**
- * **Remote power door locks with 2 stage unlock and illuminated entry**
- Manual telescopic steering wheel
- * **Power front windows**
- * **Driver and passenger 1-touch down**
- Manual tilt steering wheel
- Day-night rearview mirror

Prices and content availability as shown are subject to change and should be treated as estimates only. Actual base vehicle, package and option pricing may vary from this estimate because of special local pricing, availability or pricing adjustments not reflected in the dealer's computer system. See salesperson for the most current information.

Prepared for: Matthew Porras

Yucaipa Valley Water District

Prepared by: David Pratt

10/20/2021

Transwest Truck Center | 10150 Cherry Ave. Fontana California | 923355222



2022 F-600 Chassis 4x4 SD Regular Cab 169" WB DRW XL (F6L)

Price Level: 240 | Quote ID: YVWDValve

Selected Equip & Specs (cont'd)

- FordPass Connect 4G internet access
- Wireless phone connectivity
- 2 1st row LCD monitors
- Passenger visor mirror
- Upfitter switches
- 911 Assist emergency SOS
- AppLink smart device integration
- Front cupholders
- * **Driver and passenger door bins**

Seats and Trim

- Seating capacity of 3
- 4-way driver seat adjustment
- 4-way passenger seat adjustment
- Front 40-20-40 split-bench seat
- Manual driver lumbar support
- Centre front armrest with storage

Entertainment Features

- AM/FM stereo radio
- Steering wheel mounted radio controls
- Streaming audio
- SYNC external memory control
- 4 speakers
- Fixed antenna

Lighting, Visibility and Instrumentation

- Halogen aero-composite headlights
- Auto on/off headlights
- Light tinted windows
- Tachometer
- Compass
- * **Camera(s) - rear**
- Trip odometer
- Delay-off headlights
- Variable intermittent front windshield wipers
- Front reading lights
- Oil pressure gauge
- Outside temperature display
- Trip computer

Safety and Security

- 4-wheel ABS brakes
- 4-wheel disc brakes
- Dual front impact airbag supplemental restraint system with passenger cancel
- Safety Canopy System curtain 1st row overhead airbag supplemental restraint system
- * **Power remote door locks with 2 stage unlock and panic alarm**
- * **MyKey restricted driving mode**
- Brake assist
- Driveline traction control
- Dual seat mounted side impact airbag supplemental restraint system
- * **Remote activated perimeter/approach lighting**
- * **Security system with SecuriLock immobilizer**
- Manually adjustable front head restraints

Dimensions

General Weights

* Curb	7,425 lbs.	GVWR	22,000 lbs.
Payload	14,690 lbs.		

Prices and content availability as shown are subject to change and should be treated as estimates only. Actual base vehicle, package and option pricing may vary from this estimate because of special local pricing, availability or pricing adjustments not reflected in the dealer's computer system. See salesperson for the most current information.

Prepared for: Matthew Porras

Yucaipa Valley Water District

Prepared by: David Pratt

10/20/2021

Transwest Truck Center | 10150 Cherry Ave. Fontana California | 923355222



2022 F-600 Chassis 4x4 SD Regular Cab 169" WB DRW XL (F6L)

Price Level: 240 | Quote ID: YVWDValve

Selected Equip & Specs (cont'd)

Front Weights

Front GAWR	7,500 lbs.	* Front curb weight	4,281 lbs.
Front axle capacity	7,500 lbs.	Front spring rating	7,500 lbs.

Rear Weights

Rear GAWR	15,500 lbs.	* Rear curb weight	3,144 lbs.
Rear axle capacity	15,500 lbs.	Rear spring rating	15,500 lbs.

Trailer Type

Harness	Yes	* Brake controller	Yes
Trailer sway control	Yes		

General Trailering

5th-wheel towing capacity	21700 lbs.	Gooseneck towing capacity	21700 lbs.
Towing capacity	18340 lbs.	GCWR	30000 lbs.

Fuel Tank type

Capacity	40 gal.
----------------	---------

Interior cargo

Cargo volume	11.6 cu.ft.	Maximum cargo volume	11.6 cu.ft.
--------------------	-------------	----------------------------	-------------

Rear Frame

Height loaded	29 "	Height unloaded	34 "
---------------------	------	-----------------------	------

Powertrain

Engine Type

Block material	Iron	Cylinders	V-8
Head material	Aluminum	Ignition	Spark
Injection	Sequential MPI	Liters	7.3L
Orientation	Longitudinal	Recommended fuel	Regular unleaded
Valves per cylinder	2	Valvetrain	OHV
Variable valve control	DEVCT		

Engine Spec

Bore	4.21"	Compression ratio	10.5:1
Displacement	445 cu.in.	Stroke	3.98"

Engine Power

SAEJ1349 AUG2004 compliant	Yes	Output	350 HP @ 3,900 RPM
Torque	468 ft.-lb @ 3,900 RPM		

Alternator

* Type	Dual	* Amps	397
---------------------	-------------	---------------------	------------

Prices and content availability as shown are subject to change and should be treated as estimates only. Actual base vehicle, package and option pricing may vary from this estimate because of special local pricing, availability or pricing adjustments not reflected in the dealer's computer system. See salesperson for the most current information.

Prepared for: Matthew Porras

Yucaipa Valley Water District

Prepared by: David Pratt

10/20/2021

Transwest Truck Center | 10150 Cherry Ave. Fontana California | 923355222



2022 F-600 Chassis 4x4 SD Regular Cab 169" WB DRW XL (F6L)

Price Level: 240 | Quote ID: YVWDValve

Selected Equip & Specs (cont'd)

Battery

Amp hours	78	Cold cranking amps	750
Run down protection	Yes	*Type	Dual

Transmission

Electronic control	Yes	Lock-up	Yes
Overdrive	Yes	Speed	10
Type	Automatic		

Transmission Gear Ratios

1st	4.696	2nd	2.985
3rd	2.146	4th	1.769
5th	1.52	6th	1.275
7th	1	8th	0.854
9th	0.689	10th	0.616
Reverse Gear ratios	4.866		

Transmission Extras

Driver selectable mode	Yes	Sequential shift control	SelectShift
Oil cooler	Regular duty	PTO provision	Yes

Drive Type

4wd type	Part-time	Type	Four-wheel
----------	-----------	------	------------

Drive Feature

Limited slip differential	Mechanical	Traction control	Driveline
Power take-off provision	Yes	Locking hub control	Auto
Transfer case shift	Electronic		

Drive Axle

Ratio	4.88
-------	------

Exhaust

Material	Stainless steel	System type	Single
----------	-----------------	-------------	--------

Emissions

CARB	Federal
------	---------

Fuel Economy

Fuel type	Gasoline
-----------	----------

Driveability

Brakes

ABS	4-wheel	ABS channels	3
Type	4-wheel disc	Vented discs	Front and rear

Prices and content availability as shown are subject to change and should be treated as estimates only. Actual base vehicle, package and option pricing may vary from this estimate because of special local pricing, availability or pricing adjustments not reflected in the dealer's computer system. See salesperson for the most current information.

Prepared for: Matthew Porras

Yucaipa Valley Water District

Prepared by: David Pratt

10/20/2021

Transwest Truck Center | 10150 Cherry Ave. Fontana California | 923355222



2022 F-600 Chassis 4x4 SD Regular Cab 169" WB DRW XL (F6L)

Price Level: 240 | Quote ID: YVWDValve

Selected Equip & Specs (cont'd)

Brake Assistance

Brake assist Yes

Suspension Control

Ride Firm

Front Suspension

Independence ... Mono-beam non-independent Anti-roll bar Regular

Front Spring

Type Coil Grade HD

Front Shocks

Type HD

Rear Suspension

Independence DANA M300 rigid axle Type Leaf
 Anti-roll bar Regular

Rear Spring

Type Leaf Grade HD

Rear Shocks

Type HD

Steering

Activation Hydraulic power-assist Type Re-circulating ball

Steering Specs

of wheels 2

Exterior

Front Wheels

Diameter 19.5" Width 6.75"

Rear Wheels

Diameter 19.5" Width 6.75"
 Dual Yes

Front and Rear Wheels

Appearance Argent Material Steel

Front Tires

Aspect 70 Diameter 19.5"
 Sidewalls BSW Speed S
 Tread AS Type LT
 Width 245mm LT load rating G

Prices and content availability as shown are subject to change and should be treated as estimates only. Actual base vehicle, package and option pricing may vary from this estimate because of special local pricing, availability or pricing adjustments not reflected in the dealer's computer system. See salesperson for the most current information.

Prepared for: Matthew Porras

Yucaipa Valley Water District

Prepared by: David Pratt

10/20/2021

Transwest Truck Center | 10150 Cherry Ave. Fontana California | 923355222



2022 F-600 Chassis 4x4 SD Regular Cab 169" WB DRW XL (F6L)

Price Level: 240 | Quote ID: YVWDValve

Selected Equip & Specs (cont'd)

Rear Tires

Aspect	70	Diameter	19.5"
Sidewalls	BSW	Speed	S
Tread	AS	Type	LT
Width	245mm	LT load rating	G

Wheels

Front track	74.8"	Rear track	74.0"
Turning radius	24.2'	Wheelbase	169.0"
Rear tire outside width	93.9"		

Body Features

Front splash guards	Yes	* Skid plate(s)	1
Body material	Aluminum	Side impact beams	Yes
* Side steps	Yes	Front tow hook(s)	2

Body Doors

Door count	2
------------------	---

Exterior Dimensions

Length	254.8"	Body width	80.0"
Cab to axle	84.0"	Axle to end of frame	47.2"
Frame section modulus	12.7cu.in.	Frame yield strength (psi)	50000.0
Frame rail width	34.2"	Front bumper to Front axle	38.3"
Cab to end of frame	131.2"	Front bumper to back of cab	123.7"

Safety

Airbags

Driver front-impact	Yes	Driver side-impact	Seat mounted
Overhead	Safety Canopy System curtain 1st row	Passenger front-impact	Cancellable
Passenger side-impact	Seat mounted		

Seatbelt

Height adjustable	Front
-------------------------	-------

Security

* Immobilizer	SecuriLock	* Panic alarm	Yes
* Restricted driving mode	MyKey		

Seating

Passenger Capacity

Capacity	3
----------------	---

Prices and content availability as shown are subject to change and should be treated as estimates only. Actual base vehicle, package and option pricing may vary from this estimate because of special local pricing, availability or pricing adjustments not reflected in the dealer's computer system. See salesperson for the most current information.

Prepared for: Matthew Porras

Yucaipa Valley Water District

Prepared by: David Pratt

10/20/2021

Transwest Truck Center | 10150 Cherry Ave. Fontana California | 923355222



2022 F-600 Chassis 4x4 SD Regular Cab 169" WB DRW XL (F6L)

Price Level: 240 | Quote ID: YVWDValve

Selected Equip & Specs (cont'd)

Front Seats

Split 40-20-40 Type Split-bench

Driver Seat

Fore/aft Manual Reclining Manual
Way direction control 4 Lumbar support Manual

Passenger seat

Fore/aft Manual Reclining Manual
Way direction control 4

Front Head Restraint

Control Manual Type Adjustable

Front Armrest

Centre Yes Storage Yes

Front Seat Trim

Material Vinyl Back material Vinyl

Convenience

AC And Heat Type

Air conditioning Manual Air filter Yes

Audio System

Radio AM/FM stereo Radio grade Regular
Seek-scan Yes External memory control SYNC

Audio Speakers

Speaker type Regular Speakers 4

Audio Controls

Steering wheel controls Yes Voice activation Yes
Streaming audio Bluetooth yes

Audio Antenna

Type Fixed

LCD Monitors

1st row 2 Primary monitor size (inches) 4.2

Convenience Features

* **Retained accessory power** **Yes** 12V DC power outlet 3
Emergency SOS 911 Assist Wireless phone connectivity Bluetooth
* **Back-up alarm** **Yes** Smart device integration App link
Upfitter switches Yes

Prices and content availability as shown are subject to change and should be treated as estimates only. Actual base vehicle, package and option pricing may vary from this estimate because of special local pricing, availability or pricing adjustments not reflected in the dealer's computer system. See salesperson for the most current information.

Prepared for: Matthew Porras

Yucaipa Valley Water District

Prepared by: David Pratt

10/20/2021

Transwest Truck Center | 10150 Cherry Ave. Fontana California | 923355222



2022 F-600 Chassis 4x4 SD Regular Cab 169" WB DRW XL (F6L)

Price Level: 240 | Quote ID: YVWDValve

Selected Equip & Specs (cont'd)

Door Lock Activation

* Type **Power with 2 stage unlock** * Remote **Keyfob (all doors)**
 * Integrated key/remote **Yes**

Door Locks Extra FOB Controls

Remote engine start **Smart device only**

Instrumentation Type

Appearance **Analog**

Instrumentation Gauges

Tachometer **Yes** Oil pressure **Yes**
 Engine temperature **Yes** Transmission fluid temp **Yes**
 Engine hour meter **Yes**

Instrumentation Warnings

Oil pressure **Yes** Engine temperature **Yes**
 Battery **Yes** Lights on **Yes**
 Key **Yes** Low fuel **Yes**
 Door ajar **Yes** Service interval **Yes**
 Brake fluid **Yes**

Instrumentation Displays

Clock **In-radio display** Compass **Yes**
 Exterior temp **Yes** Systems monitor **Yes**
 * Camera(s) - rear **Yes**

Instrumentation Feature

Trip computer **Yes** Trip odometer **Yes**

Steering Wheel Type

Material **Urethane** Tilting **Manual**
 Telescoping **Manual**

Front Side Windows

* Window 1st row activation **Power**

Window Features

* 1-touch down **Driver and passenger** * 1-touch up **Driver and passenger**
 Tinted **Light**

Front Windshield

Wiper **Variable intermittent**

Rear Windshield

Window **Fixed**

Prices and content availability as shown are subject to change and should be treated as estimates only. Actual base vehicle, package and option pricing may vary from this estimate because of special local pricing, availability or pricing adjustments not reflected in the dealer's computer system. See salesperson for the most current information.

Prepared for: Matthew Porras

Yucaipa Valley Water District

Prepared by: David Pratt

10/20/2021

Transwest Truck Center | 10150 Cherry Ave. Fontana California | 923355222



2022 F-600 Chassis 4x4 SD Regular Cab 169" WB DRW XL (F6L)

Price Level: 240 | Quote ID: YVWDValve

Selected Equip & Specs (cont'd)

Interior

Passenger Visor

Mirror Yes

Rear View Mirror

Day-night Yes

Headliner

Coverage Full Material Cloth

Floor Trim

Coverage Full Covering Vinyl/rubber

Trim Feature

Gear shifter material Urethane Interior accents Chrome

Lighting

Dome light type Fade Front reading Yes

* **Illuminated entry** **Yes** Variable IP lighting Yes

Storage

* **Driver door bin** **Yes** Front Beverage holder(s) Yes

Glove box Locking * **Passenger door bin** **Yes**

Illuminated Yes Instrument panel Covered bin

Dashboard Yes

Legroom

Front 43.9"

Headroom

Front 40.8"

Hip Room

Front 62.5"

Shoulder Room

Front 66.7"

Interior Volume

Passenger volume 64.6 cu.ft.

Prices and content availability as shown are subject to change and should be treated as estimates only. Actual base vehicle, package and option pricing may vary from this estimate because of special local pricing, availability or pricing adjustments not reflected in the dealer's computer system. See salesperson for the most current information.

Prepared for: Matthew Porras

Yucaipa Valley Water District

Prepared by: David Pratt

10/20/2021

Transwest Truck Center | 10150 Cherry Ave. Fontana California | 923355222



2022 F-600 Chassis 4x4 SD Regular Cab 169" WB DRW XL (F6L)

Price Level: 240 | Quote ID: YVWDVale

Warranty

Standard Warranty

Basic

Distance 36,000 miles Months 36 months

Powertrain

Distance 60,000 miles Months 60 months

Corrosion Perforation

Distance Unlimited miles Months 60 months

Roadside Assistance

Distance 60,000 miles Months 60 months

Prices and content availability as shown are subject to change and should be treated as estimates only. Actual base vehicle, package and option pricing may vary from this estimate because of special local pricing, availability or pricing adjustments not reflected in the dealer's computer system. See salesperson for the most current information.



Date: November 16, 2021 **Task:** Not Applicable

Prepared By: Joseph B. Zoba, General Manager

Subject: Review and Discussion about the Draft Request for Proposals for Professional Public Relations Services for Calendar Year 2022

Recommendation: That the Board authorize the General Manager to finalize and distribute the Request for Proposals.

The District staff has prepared a draft Request for Proposals for Public Relations and Outreach services for Calendar Year 2022. The attached draft document will be reviewed and discussed at the board meeting.



Request for Proposals

2022 Public Relations and Outreach Services

Proposal No. 211116

Response Due by _____, 2021 at 2:00 p.m.

Yucaipa Valley Water District
12770 Second Street
Yucaipa, California 92399

Yucaipa Valley Water District Contract Administrators and District Liaison:

Joseph Zoba, General Manager
izoba@yvwd.us - Phone (909) 797-5119 x2

Yucaipa Valley Water District
2022 Public Relations and Outreach Services

Page 2 of 20

Yucaipa Valley Water District (the “District” or “District”) is accepting proposals for public relations and outreach services from qualified firms (“Proposers”) to assist with the preparation of various marketing products such as press releases, illustrations, videos, brochures, and informational documents.

This is not a commitment to procure this work, but a request for proposals and the costs to complete the work. The District will decide to proceed based on the proposal pricing submitted.

The final date for submitting a bid proposal is Wednesday, _____, 2021 at 2:00 pm to Joseh Zoba, 12770 Second Street, Yucaipa, California 92399.

Your proposal envelope must be sealed and clearly marked “**Public Relations and Outreach Services for 2022**”.

The District reserves the right to accept or to reject any and all bids proposals, to waive any irregularities and to make an award that is determined by the District to be in the best interest of the Yucaipa Valley Water District.

Proposals must comply with the proposal requirements provided herein. Proposals will be evaluated and ranked by District staff members. Proposers must be willing to sign an agreement with the terms and conditions shown in the District’s Proposed Professional Services Agreement attached as Exhibit C.

Interviews may be scheduled for proposers selected based on criteria in the RFP. The District reserves the right to postpone the interview date, or cancel an interview, at its sole discretion. Proposers shall be notified in advance of any such postponement or cancellation.

Scope of Services

The Yucaipa Valley Water District (“District”) is looking for a cost effective, creative approach for communicating with and engaging its customers and to augment public relations and outreach support by District staff.

Background

The Yucaipa Valley Water District is one of the few public agencies in the Santa Ana Watershed to remove total dissolved solids at our wastewater treatment plant to protect water quality throughout the Watershed. These regulations were adopted by the Regional Water Quality Control Board in 2004 and forced the District to upgrade the wastewater treatment plant, construct reverse osmosis equipment, and build a 15-mile brine disposal pipeline to connect to the Inland Empire Brineline operated by the Santa Ana Watershed Project Authority.

Before building these facilities, the Board of Directors decided to backcast our future plans in order to visualize the infrastructure needed to meet the regulatory requirements and build a sustainable community. The following illustration is used to show how backcasting can result in different results as compared to forecasting future outcomes. The important point of backcasting is that instead of making separate, distinct decisions, the District made decisions that were geared towards a future fully integrated system.

Backcasting

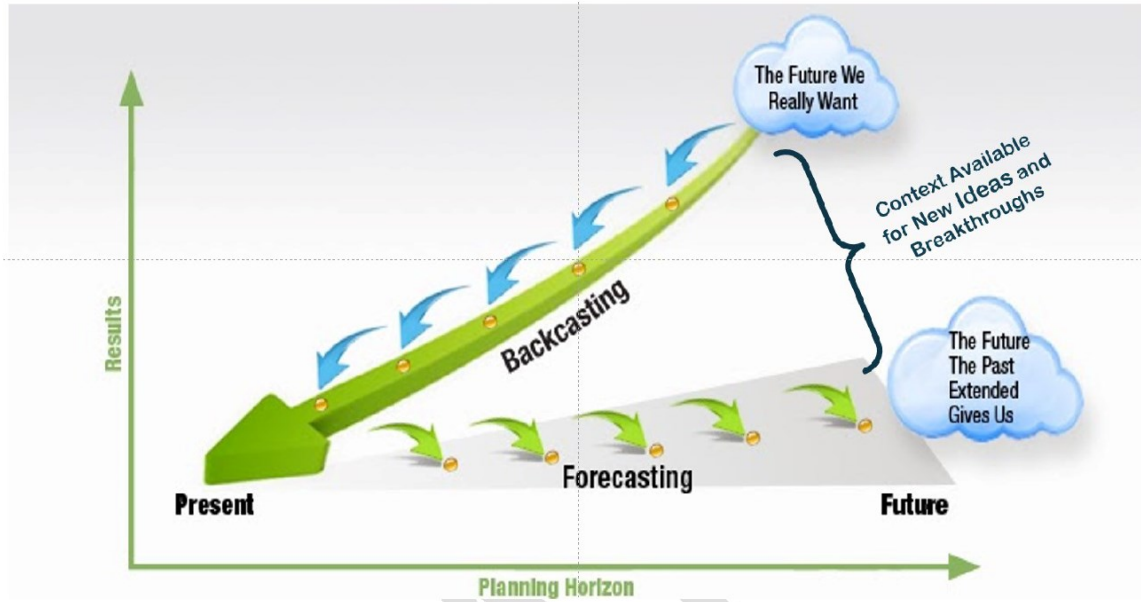

This coordinated process allowed the Yucaipa Valley Water District to fully integrate our drinking water, sewer, and recycled water systems. For example, our water treatment operators are cross-trained as sewer treatment operators since the two treatment processes have so much in common. The District has recognized that special districts that have drinking water, sewer, and recycled water authority have significantly more opportunities than single-function water agencies.

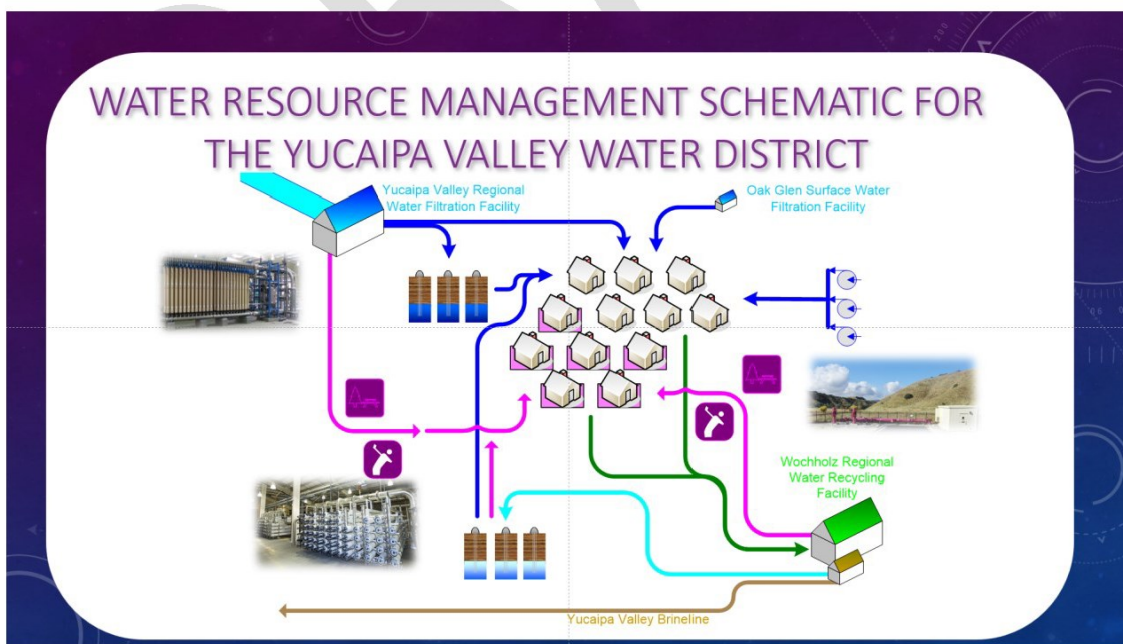

Branding Components

Immediately after constructing the reverse osmosis system and brineline, the District recognized that a specialized business in our community ([Sorenson Engineering](#)) was able to expand and hire more employees because the District's wastewater treatment plant was able to receive the concentrated salts discharged from their on-site reverse osmosis system. This business was close to relocating to an area that had more relaxed pretreatment requirements. Other businesses that would benefit from the District's unique system include businesses with food production, pharmaceuticals, and manufacturing. The selected consultant should develop information to show businesses that there is an opportunity to locate into the Yucaipa Valley Water District service area.

An additional benefit of the reverse osmosis system at the wastewater treatment plant is the ability to produce ultra-pure recycled water for the community by removing salts and minerals from the recycled water supply. There are only about 5-10 wastewater treatment plants in California that have reverse osmosis systems. While reverse osmosis systems are generally energy intensive, the District is currently designing a solar array, battery storage, and natural gas generators to reduce our demand for electricity from the grid making the wastewater treatment plant more resilient to power outages in the future.

The District's wastewater treatment plant treats about 4 million gallons per day. The reverse osmosis system is currently sized at 2.5 million gallons per day to remove just enough salts to meet the Regional Board requirements. The District is now embarking on the expansion of the reverse osmosis (RO) system to install 6 million gallons per day of treatment capacity. This will provide full RO treatment for every drop of recycled water produced. Also, a new [closed circuit reverse osmosis system](#) is being added to expansion of the reverse osmosis system to reduce the amount of wasted water generated from the reverse osmosis process thereby allowing us to recover more recycled water.

The District has been expanding the existing recycled water system used for irrigation of schools, parks, and golf courses to also use recycled water for front/rear yard irrigation of new homes. Each new home now has two water meters – one for irrigation and one for drinking water use in the homes. While the fixed monthly costs for this dual system are higher than typical homes, the new homes only use about 25% of the drinking water used in older homes in our community. This means that five new homes use the same amount of drinking water as one older home in our community. An article from Civil Engineering magazine that highlighted our dual-plumbed system is attached to further explain this system.



In the winter months the District will have excess recycled water as a result of reduced irrigation demands. With excess high purity recycled water, the District will be able to inject the ultra-pure recycled water into the groundwater basin to create a new drinking water supply that will be drought tolerant and reduce our need to import water from northern California. This Aquifer Storage and Recovery System is an important component that will receive a great deal of attention during the next calendar year.

The District would like to explore rebranding of the wastewater treatment plant and the possibility of using the branded concept of "Recycled Pure" as a tool to communicate all of the projects and benefits listed above. The District has obtained the www.recycledpure.com domain that would be used to host information about this program in addition to the District's website. The Recycled Pure domain would be used as a tool to communicate our project to the community, but also show other water districts the benefits of investing in infrastructure that fully integrates drinking water, sewer, recycled water, brine disposal systems, and power production. We are proud that an agency that serves only 50,000 people was able to construct and integrate a [fully sustainable system](#) for our community.

The consultant retained shall provide a thoughtful and comprehensive proposal that includes a fixed monthly retainer for calendar year 2022 that specifically identifies planned, measurable, and tangible public relations results that would best illustrate the District's proactive and agile ability to meet the needs of the community.

Tasks to support objectives of the public relations and outreach program should include but are not limited to the following:

Communication Services

- Plan and implement a program to gain and enhance the District's presence involving:
 - Social media;
 - Website refresh and upgrades;
 - Video clips;
 - Summary of the District's operations;
 - Historical information; and
- Provide public relations and support the District staff with the anticipated ground breaking ceremonies for the following projects:
 - Wochholz Regional Water Recycling Energy Resiliency Project;
 - Yucaipa Valley Regional Water Filtration Facility Energy Resiliency Project;
 - North Bench Recycled Water System Improvements; and the
 - Recycled Water Fill Station
- Develop news releases, media advisories, articles, website content and fact sheets for District events, initiatives, projects, and services.
- Develop a series of new customer on-boarding engagement email messages and content about the District services, meetings, and service options.
- Provide written news and information about the following services, as well as the production of six (6) three-minute videos about the following services and activities by the District:
 - Brine disposal;
 - Cross-connection needs and issues;
 - Dual-plumbing requirements for new homes;

- Emergency preparedness;
 - Environmental protection;
 - General water issues;
 - Geographical Information Systems (GIS);
 - Operations and maintenance activities;
 - Recycled water fill station;
 - Recycled water recharge;
 - Recycled water;
 - Reverse osmosis needs and opportunities;
 - Science, technology, engineering, and math (STEM) in the water/sewer industry;
 - Sewer collection;
 - Sewer treatment;
 - State Water Project partners (SBVMWD and SGPWA);
 - Sustainability goals;
 - Water supply sources; and
 - Water/sewer operator certifications.
- Develop and implement a communication strategy, material, and videos for informing and training recycled water customers that purchase or rent dual-plumbed homes.
 - Provide crisis communication counsel as necessary
 - Provide Spanish translation services for targeted communications pieces

Consultants are encouraged to reply in any way they deem necessary to show a uniqueness of approach; and knowledge of the Yucaipa Valley Water District's service area and customer base. Consultants are further encouraged to describe how they would assist the Yucaipa Valley Water District in accomplishing a successful customer outreach campaign that paves a favorable perception of the agency out into the future.

Special Considerations:

1. Yucaipa Valley Water District owns all rights to generated, produced draft and final materials in native file formats, including intellectual property rights.
2. All products will be provided in electronic formats.
3. This is a single-year effort ending in December 2022. The contract may be followed by two, one (1) year extensions in accordance with approved budgets and specific task approvals by the Board of Directors.

Proposal Requirements

- A. Work Plan and Methodology - Describe the firm's approach to the project. The proposal should set forth a detailed work plan for completing tasks including a tentative schedule with milestones and product deliverables.
- B. Project Staffing - Identify the Project Manager and responsibilities of each project team member. Provide a resume of each team member including relevant experience in conducting assessments of agencies responsible for public communication and outreach, especially on the local government level.

In the event of proposed staff changes, the District will require that replacement staff meet the same level of qualifications and equivalent rates as the staff submitted. The Yucaipa Valley Water District reserves the right to approve or reject replacements.

- C. Related Experience - Describe recent and relevant experience of the firm in conducting communications assessments of water districts responsible for public communications, as well as other major relevant projects within the past three years. Provide a minimum of three references including the name of the client, description of work done, dates of the project, primary client contact including the address and telephone number, name of the firm's Project Manager and members of the project team. Finalists will be asked to provide samples of public communication and citizen involvement studies completed by the firm in the past three years.
- D. Proposed Cost - Provide the monthly retainer, or total cost for the project, including fees, reimbursables, and number of hours estimated to be spent on each major work task. The Yucaipa Valley Water District shall not, in any event, be liable for any pre-contractual expenses incurred by respondents in preparation of the proposals, and respondents shall not include any such expenses as part of their proposal. The Yucaipa Valley Water District shall also not be responsible for any associated fees with regard to insurance, licenses, or taxes.
- E. Written Agreement - Should the proposer desire to take exception to any term or condition set forth in the RFP, said exception must be clearly identified in the response to the RFP. Selected consultant must be willing to enter into a written agreement with the Yucaipa Valley Water District to provide all services specified in the RFP. Consultant must also be able to secure appropriate professional insurance as required by the District.

Evaluation Process and Criteria

- A. Award criteria will include, but is not limited to:
- Qualifications, capabilities, and experience of the firm and individuals performing the engagement.
 - Step by step approach to the engagement and detailed schedule for completion.
 - Completeness and responsiveness of the proposal submitted.
 - Reference verification.
 - All costs pertaining to the engagement including travel and miscellaneous expenses.
- B. The Yucaipa Valley Water District may waive any informality, irregularity, or error in a proposal or in the process for obtaining proposals.
- C. The Yucaipa Valley Water District reserves the right to reject any proposal submitted which is not in substantial compliance with the requirements set forth in the Request for Proposals.

- D. The Yucaipa Valley Water District reserves the right to reject all proposals and cancel the proposal process.
- E. The proposal deemed most advantageous to the Yucaipa Valley Water District will be awarded the contract (even though it may not be the proposal with the lowest proposed fee). The District reserves the right to select portions of the proposal based on the fee quoted for each major task.
- F. Determination of acceptance shall be based on the judgment of the District staff.

General Information and Requirements

- A. Receiving Office: Proposals will be accepted until Wednesday, _____, 2021 at 2:00 pm by Joseph Zoba, General Manager 12770 Second Street, Yucaipa, California 92399. Bid proposal envelopes must be sealed and clearly marked "**Public Relations and Outreach Services for 2022**".
- B. Rejection of Proposals: The District reserves the right to accept or reject any or all proposals received as a result of this request. The District shall not be obligated to award a contract solely on the basis of any response made to this Request for Proposal, nor does District intend to, nor will it be obligated to pay for the information solicited or obtained.
- C. Incurred Consultant Costs: District will not be liable for any costs incurred by Consultants or other respondents to this Request for Bid Proposals, prior to issuance of an agreement, contract, or other similar acquisition documents.
- D. Qualification: The selected Consultant shall have a proven record of performing work of a similar nature to the project described for a minimum of three (3) years. The Consultant may be required to submit the names of three (3) references and include the name of the entity, contact person, telephone number and a brief description. Include an outline describing company's profile and ability to perform the work.
- E. Other Provisions: The Consultant shall list any other criteria or requirements to delineate responsibility for any additional items/tasks to be completed by either District or Consultant. These shall be in addition to those previously detailed or explained in this Request for Proposals.
- F. Contract Terms: If awarded the Contract, the undersigned agrees to start work on this project within fifteen (15) working days or as otherwise directed by the District Liaison (or designee) in accordance with these specifications.
- G. Insurance: The Consultant shall indemnify and hold harmless Yucaipa Valley Water District and all his officers, agents and employees' representatives all suits, actions, or claims of any character, name and description brought for or on account of any injuries or damages received or sustained by any person, persons, or property by or from the said Consultants or their employees or by or in consequence of any neglect in safeguarding the work or through the use of unacceptable materials in the work or by or on account of any act or omission, neglect, or misconduct of the said Consultant.

Consultant, at their expense, must maintain during the term of any subsequent contract the following insurance:

- Broad form General Liability Insurance (occurrence basis only) with minimum limits of \$1 million dollars per occurrence and \$1 million dollars aggregate.
- Workers' Compensation and Employer's Liability Insurance, California statutory limits of liability.
- Each Consultant shall take out and maintain during the life of this contract Workers' Compensation Insurance for all employees employed at the site of the project and, in case any of the work is sublet, the Consultant shall require the sub-Consultant to provide such insurance. Proof of compliance with the Workers' Compensation Laws and Social Security Laws shall be filed with and kept in full force and effect on file with the County at all times, until all the work on the project provided to be done under this contract has been fully and finally completed. This shall be an absolute responsibility and duty of the Consultant, who agrees to indemnify and save harmless the County from any contributions or taxes or liability thereof.
- Comprehensive Automobile Liability (including hired and non-owned vehicles) with California no-fault coverage, with minimum limits for bodily injury of \$500,000 each person and \$1 million dollars each accident and with minimum limits for property damage of \$500,000 each accident.

Insurance policies must name the Consultant as the insured, along with Yucaipa Valley Water District as additional insured, and must not be canceled or materially changed without at least 30 days prior notice from the Consultant to Yucaipa Valley Water District. The Consultant must submit certificates evidencing the insurance to Yucaipa Valley Water District at the time the Consultant executes the contract, and at least 15 days prior to the expiration dates of expiring policies.

Certificates of Insurance acceptable to Yucaipa Valley Water District shall be filed with Yucaipa Valley Water District prior to commencement of the work. The Consultant agrees that its insurance carriers waive subrogation against Yucaipa Valley Water District, its agents, or employees with respect to any loss covered by the Consultant's insurance.

- H. Freedom of Information Act: Information submitted in Consultant proposals becomes public information and as such is subject to public disclosure and review under the California Freedom of Information Act. Information contained in the Consultant's proposal which is company confidential must be clearly identified in the proposal itself.

- Exhibit A -

**Professional Services Agreement for
2022 Public Relations and Outreach Services**

This Professional Services Agreement ("Agreement") is entered into to be effective as of _____, 2022 ("Effective Date") by and between the following parties (sometimes referred to herein individually as "Party" and collectively as "Parties"):

District	Consultant
Yucaipa Valley Water District 12770 Second Street Post Office Box 730 Yucaipa, California 92399 Attention: Joseph Zoba, General Manager Telephone: (909) 797-5119 x2	 Attention: _____ Telephone: _____ Tax ID: _____

District Liaison	Consultant Liaison
Name _____ Title _____	Name _____ Title _____

NOW, THEREFORE, in consideration of the promises and mutual benefits, which will result to the Parties in carrying out the terms of this Agreement, it is mutually agreed as follows:

1. **Scope of Work.** Consultant agrees to furnish necessary professional and technical services to accomplish those elements outlined in the Scope of Work attached hereto as "Attachment A", and by this reference made a part of this Agreement.
 - A. The Consultant shall be responsible for the professional quality, technical accuracy, completeness, and coordination of all design, drawings, specifications, and other services furnished by the Consultant under this Agreement, including the work performed by its Subconsultants. Where approval by the District is indicated, it is understood to be conceptual approval only and does not relieve the Consultant of responsibility for complying with all laws, codes, industry standards and liability for damages caused by errors, omissions, noncompliance with industry standards, and/or negligence on the part of the Consultant or its Subconsultants.
 - B. Consultant is responsible for the quality of work prepared under this Agreement and shall ensure that all work is performed to the standards of best engineering practice for clarity, uniformity, and completeness. In the event that work is not performed to the satisfaction of the District and does not conform to the requirements of this Agreement or any applicable industry standards, the Consultant shall, without additional compensation, promptly correct or revise any errors or deficiencies in its designs, drawings, specifications, or other services

within the timeframe specified by the District Liaison. The District may charge to Consultant all costs, expenses and damages associated with any such corrections or revisions.

- C. All drawings, figures, and other work shall be produced by Consultants and Subconsultants using the District standard software or software approved in writing. Electronic files shall be subject to an acceptance period of fourteen (14) calendar days during which the District shall perform appropriate acceptance tests. Consultant shall correct any discrepancies or errors detected and reported within the acceptance period at no additional cost to the District.
- D. All professional services performed by the Consultant, including but not limited to all drafts, data, correspondence, proposals, reports, and estimates compiled or composed by the Consultant, pursuant to this Agreement, are for the sole use of the District, its agents, and employees. Neither the documents nor their contents shall be released to any third party without the prior written consent of the District. This provision does not apply to information that (a) was publicly known, or otherwise known to the Consultant, at the time that it was disclosed to the Consultant by the District, (b) subsequently becomes publicly known to the Consultant other than through disclosure by the District.

2. Compensation. Total compensation shall be paid to Consultant for services in accordance with the following provisions:

A. Total Compensation.

Total compensation shall be in an amount not to exceed _____ (\$ _____) and costs shall not exceed the sum set forth in Attachment "B" - Fee Proposal.

B. Labor.

As a portion of the total compensation to be paid to Consultant, the District shall pay to Consultant a sum equal to the burdened salaries (salaries plus benefits) actually paid by Consultant charged on an hourly-rate basis to this project and paid to the personnel of Consultant. Upon request of the District, Consultant shall provide the District with certified payroll records of all employees' work that is charged to this project.

C. Direct Costs.

The District shall pay to Consultant and Sub-Consultants the actual costs of permits and associated fees, travel, and licenses for an amount not to exceed the sum set forth in Attachment "B" - Fee Proposal. The District shall also pay to Consultant actual costs for equipment rentals, leases, or purchases with prior written approval of the District. Upon request, Consultant shall provide to the District receipts and other documentary records to support Consultant's request for reimbursement of these amounts. All incidental expenses shall be included in overhead pursuant to Section 2.A. above.

D. Limitation of Costs.

If, at any time, Consultant estimates the cost of performing the services described in Consultant's Proposal will exceed the not-to-exceed amount of the Agreement, including approved additional compensation, Consultant shall notify the District immediately, and in writing. This written notice shall indicate the additional amount necessary to complete the services. Any cost incurred in excess of the approved not-to-exceed amount, without the express written consent of the District's authorized representative shall be at Consultant's own risk. This written notice shall be provided separately from, and in addition to any notification requirements contained in the Consultant's invoice and monthly progress report. Failure to notify the District that the services cannot be completed within the authorized not-to-exceed amount is a material breach of this Agreement.

E. Reallocation of Total Compensation.

The District, by its General Manager, shall have the right to approve a reallocation of the incremental amounts constituting the total compensation, provided that the total compensation is not increased.

3. Payment

A. Monthly Invoice.

Consultant shall include in its monthly invoice, a detailed breakdown of costs associated with the performance of any corrections or revisions of the work for that invoicing period. Consultant shall allocate costs in the same manner as it would for payment requests as described in this Section of the Agreement. Consultant shall warrant and certify the accuracy of these costs and understand that submitted costs are subject to Audit Provisions as provided herein.

B. If the District determines that the work under this Agreement or any specified project element hereunder, is incomplete and that the amount of payment is in excess of:

- i. The amount considered by the District's Liaison to be adequate for the protection of the District; or
- ii. The percentage of the work accomplished for each project element.

The District Liaison may, at the District's sole discretion, retain an amount equal to that which insures that the total amount paid to that date does not exceed the percentage of the completed work for each project element or the project in its entirety.

4. California Department of Industrial Relations ("DIR") Registration and Record of Wages

- A. To the extent Consultant's employees and/or subconsultants who will perform work for which Prevailing Wage Determinations have been issued by the DIR and as more specifically defined under Labor Code Section 1720 et seq, Consultant and subconsultants shall comply with the registration requirements of Labor Code Section 1725.5. Pursuant to Labor Code Section 1771.4, the Work is subject to

compliance monitoring and enforcement by the DIR.

- B. The Consultant and subconsultants shall maintain accurate payroll records and shall comply with all the provisions of Labor Code Section 1776 and shall submit payroll records to the Labor Commissioner pursuant to Labor Code Section 1771.4(a) (3). Penalties for non-compliance with the requirements of Section 1776 may be deducted from progress payments per Section 1776.
- C. Pursuant to Labor Code Section 1776, the Consultant and subconsultants shall furnish a copy of all certified payroll records to District and/or general public upon request, provided the public request is made through District, the Division of Apprenticeship Standards, or the Division of Labor Enforcement of the Department of Industrial Relations.
- D. The Consultant and subconsultants shall comply with the job site notices posting requirements established by the Labor Commissioner per Title 8, California Code of Regulation Section 16461(e).

5. Insurance

A. General

- i. Insurance shall be issued and underwritten by insurance companies acceptable to the District.
- ii. Insurers must have an "A-" Policyholder's Rating, or better, and Financial Rating of at least Class VIII, or better, in accordance with the most current A.M. Best's Guide Rating. However, the District will accept State Compensation Insurance Fund, for the required policy of Worker's Compensation Insurance subject to the District's option to require a change in insurer in the event the State Fund financial rating is decreased below "B". Further, the District will require Consultant to substitute any insurer whose rating drops below the levels herein specified. Said substitution shall occur within twenty (20) days of written notice to Consultant, by the District or its agent.
- iii. Coverage shall be in effect prior to the commencement of any work under this Agreement.

B. General Liability

The Consultant shall maintain, during the life of this Agreement, including the period of warranty, Commercial General Liability Insurance written on an occurrence basis providing the following minimum limits of liability coverage:

- i. One Million Dollars (\$1,000,000) per occurrence with One Million Dollars (\$1,000,000) aggregate. Said insurance shall include coverage for the following hazards: broad form property damage, blanket contractual liability, independent Consultant liability, mobile equipment, owners and Consultant protective liability, and cross liability and severability of interest clauses. A statement on an insurance certificate will not be accepted in

lieu of the actual additional insured endorsement(s).

C. Umbrella Excess Liability

The minimum limits of general liability and Automotive Liability Insurance required, as set forth herein, shall be provided for through either a single policy of primary insurance or a combination of policies of primary and umbrella excess coverage. Umbrella excess liability coverage shall be issued with limits of liability which, when combined with the primary insurance, will equal the minimum limits for general liability and automotive liability.

D. Automotive / Vehicle Liability Insurance

The Consultant shall maintain a policy of Automotive Liability Insurance on a comprehensive form covering all owned, non-owned, and hired automobiles, trucks, and other vehicles providing the following minimum limits of liability coverage: Combined single limit of One Million Dollars (\$1,000,000) or alternatively, One Million Dollars (\$1,000,000) per person for bodily injury and One Million Dollars (\$1,000,000) per accident for property damage. A statement on an insurance certificate will not be accepted in lieu of the actual additional insured endorsement.

E. Workers' Compensation Insurance

The Consultant shall provide such Workers' Compensation Insurance as required by the Labor Code of the State of California in the amount of the statutory limit, including Employer's Liability Insurance with a minimum limit of One Million Dollars (\$1,000,000) per occurrence. Such Worker's Compensation Insurance shall be endorsed to provide for a waiver of subrogation in favor of the District. A statement on an insurance certificate will not be accepted in lieu of the actual endorsements unless the insurance carrier is State of California Insurance Fund and the identifier "SCIF" and endorsement numbers 2570 and 2065 are referenced on the certificate of insurance. If an exposure to Jones Act liability may exist, the insurance required herein shall include coverage for Jones Act claims.

F. Cancellation Notice

Each insurance policy required herein shall be endorsed to state that coverage shall not be cancelled by either party, except after thirty (30) days' prior written notice. The policy shall not be cancelled until thirty (30) days after written notice is given to the District except for nonpayment of premium, which shall require not less than ten (10) days written notice to the District. Should there be changes in coverage or an increase in deductible or SIR amounts, the Consultant shall send to the District a certified letter which includes a description of the changes in coverage and/or any increase in deductible or SIR amounts. The certified letter must be received by the District as soon as practicable if the change would reduce coverage or increase deductibles or SIR amounts or otherwise reduce or limit the scope of insurance coverage provided to the District.

G. Subconsultants

The Consultant shall be responsible to establish insurance requirements for any Subconsultant hired by the Consultant. The insurance shall be in amounts and types reasonably sufficient to deal with the risk of loss involving the Subconsultant's operations and work.

H. Limits are Minimums

If the Consultant maintains higher limits than any minimums shown above, then District requires and shall be entitled to coverage for the higher limits maintained by Consultant.

6. Scope Changes.

In the event of a change in the Scope of Work, requested by District, the parties hereto shall execute an amendment to this Agreement setting forth with particularity all terms of the new Agreement, including but not limited to any additional Consultant's fees.

7. Project Team and Subconsultants.

Consultant shall provide to District, prior to execution of this Agreement, the names and full description of all Subconsultants and Consultant's project team members anticipated to be used on this project by Consultant. Consultant shall include a description of the scope of work to be done by each Subconsultant and each Consultant's project team member. Consultant shall include the respective compensation amounts for Consultant and each Subconsultant on a per-project-element basis, broken down as indicated in Section 2 - Compensation.

8. Legal Relationship Between Parties

The legal relationship between the parties hereto is that of an independent Consultant and nothing herein shall be deemed to make Consultant an employee of the District.

9. Notices

All notices hereunder and communications regarding the interpretation of the terms of this Agreement, or changes thereto, shall be effected by delivery of said notices in person or by depositing said notices in the U.S. mail, registered or certified mail, return receipt requested, postage prepaid. Notices shall be mailed to the District and Consultant as provided above.

All communication regarding the Scope of Work, will be addressed to the Project Liaison. Direction from other District's staff must be approved in writing by the District's Liaison prior to action from the Consultant.

10. Termination

The District may terminate this Agreement at any time, without cause, upon giving thirty (30) days written notice to Consultant. In the event of such termination, Consultant shall be entitled to compensation for work performed on a prorated basis through and including the effective date of termination.

Consultant shall be permitted to terminate this Agreement upon thirty (30) days written notice only if Consultant is not compensated for billed amounts in accordance with the provisions of this Agreement, when the same are due.

Notice of termination shall be mailed to the District and/or Consultant in accordance with the Notices provisions contained herein.

11. Documents and Study Materials

The documents and study materials for this project shall become the property of the District upon the termination or completion of the work. Consultant agrees to furnish to the District copies of all memoranda, correspondence, computation, and study materials in its files pertaining to the work described in this Agreement.

12. Compliance

Consultant certifies by the execution of this Agreement that it pays employees not less than the minimum wage as defined by law, and that it does not discriminate in its employment with regard to race, color, religion, sex or national origin; that it is in compliance with all federal, state and local directives and executive orders regarding non-discrimination in employment; and that it agrees to demonstrate positively and aggressively the principle of equal opportunity in employment.

13. Agreement Execution Authorization

Both the District and Consultant do covenant that each individual executing this document by and on behalf of each party is a person duly authorized to execute agreements for that party.

14. Dispute Resolution

In the event of a dispute arising between the parties regarding performance or interpretation of this Agreement, the dispute shall be resolved by binding arbitration under the auspices of the Judicial Arbitration and Mediation Service ("JAMS"), or similar organization or entity conducting alternate dispute resolution services.

15. Attorney's Fees, Costs and Necessary Disbursements

If any action at law or in equity or if any proceeding in the form of an Alternative Dispute Resolution (ADR) is necessary to enforce or interpret the terms of this Agreement, the prevailing party shall be entitled to reasonable attorney's fees, costs and necessary disbursements in addition to any other relief to which it may be entitled.

16. Progress Reports

Monthly progress reports shall be submitted for review by the tenth day of the following month and must include as a minimum:

- Current activities,
- Future activities,
- Potential items that are not included in the Scope of Work,

- Concerns and possible delays,
- Percentage of completion, and
- Budget status.

17. Indemnification

To the fullest extent permitted by law, Consultant shall indemnify, defend (at Consultant's sole cost and expense and with legal counsel approved by the District, which approval shall not be unreasonably withheld), protect and hold harmless the District and all of District's officers, directors, employees, Consultants, and agents (collectively the "Indemnified Parties"), from and against any and all claims, damages, liabilities, causes of action, suits, arbitration awards, losses, judgments, fines, penalties, costs and expenses including without limitation, reasonable attorneys' fees, disbursements and court costs, and all other professional, expert or Consultants fees and costs and the District's general and administrative expenses (individually, a "Claim", or collectively, "Claims") which may arise from or are in any manner related, directly or indirectly, to any work performed, or any operations, activities, or services provided by Consultant in carrying out its obligations under this Agreement to the extent of the negligent, recklessness and/or willful misconduct of Consultant, its principals, officers, agents, employees, Consultant's suppliers, Consultants, subconsultants, subconsultants, and/or anyone employed directly or indirectly by any of them. Notwithstanding the foregoing, nothing herein shall be construed to require Consultant to indemnify the Indemnified Parties from any Claim arising from:

- A. The sole or active negligence or willful misconduct of the Indemnified Parties; or
- B. A natural disaster or other act of God, such as an earthquake; or
- C. The independent action of a third party who is neither one of the Indemnified Parties nor the Consultant, nor its principal, officer, agent, employee, nor Consultant's supplier, Consultant, subconsultant, subconsultant, nor anyone employed directly or indirectly by any of them.

The terms of this Agreement are contractual and the result of negotiation between the parties hereto. Accordingly, any rule of construction of contracts (including, without limitation, California Civil Code Section 1654) that ambiguities are to be construed against the drafting party, shall not be employed in the interpretation of this Agreement.

18. Force Majeure

Neither party shall have any claim or right against the other for any failure of performance where such failure of performance is caused by or is the result of causes beyond the reasonable control of the other party due to any occurrence commonly known as a "force majeure," including, but not limited to: acts of God; fire, flood, or other natural catastrophe; acts of any governmental body; labor dispute or shortage; national emergency; insurrection; riot; or war.

19. Independent Consultant.

- A. **Status.** The Parties hereby acknowledge that in rendering the Services provided hereunder, Consultant shall be deemed to be an independent Consultant and shall

not be deemed in any way an agent, partner or joint venturer of the District. Consultant acknowledges and agrees that, as an independent Consultant, it is solely responsible for the payment of any and all taxes and/or assessments imposed on account of payment to Consultant or the performance of Services by Consultant pursuant to this Agreement.

- B. **Agency Restrictions.** Consultant understands and agrees that Consultant shall not represent itself to third parties to be the agent, employee, partner or joint venturer of the District. Furthermore, Consultant shall not make any statements on behalf of or otherwise purporting to bind the District in any contract or otherwise related agreement. Consultant further agrees and acknowledges that Consultant does not have the authority to and shall not sign any contract on behalf of the District or any of its subsidiaries or affiliates. Consultant shall not obligate the District or any of its subsidiaries or affiliates to do any other act that would bind the District or any of its subsidiaries or affiliates in any manner.

20. **Miscellaneous.**

- A. **Entire Agreement.** This Agreement constitutes the entire agreement between the Parties and supersedes any prior understandings, agreements, or representations by or between the Parties, written or oral, to the extent they have related in any way to the subject matter hereof.
- B. **No Third-Party Beneficiaries.** This Agreement shall not confer any rights or remedies upon any person or entity other than the Parties and their respective successors and permitted assigns.
- C. **Succession.** This Agreement shall be binding upon and inure to the benefit of the Parties named herein and their respective successors and permitted assigns.
- D. **Headings.** The section headings contained in this Agreement are inserted for convenience only and shall not affect in any way the meaning or interpretation of this Agreement
- E. **Governing Law; Venue.** This Agreement shall be governed by and construed in accordance with the domestic laws of the State of California without giving effect to any choice or conflict of law provision or rule (whether of the State of California or any other jurisdiction) that would cause the application of the laws of any jurisdiction other than the State of California. Venue for any suit, action or proceeding shall exist exclusively in the courts having jurisdiction over the County of San Bernardino.
- F. **Counterparts.** This Agreement may be executed in one or more counterparts, each of which shall be deemed an original but all of which together will constitute one and the same instrument.
- G. **Waivers.** No waiver by any Party of any default, misrepresentation, or breach of warranty or covenant hereunder, whether intentional or not, shall be deemed to extend to any prior or subsequent default, misrepresentation, or breach of warranty or covenant hereunder or affect in any way any rights arising by virtue of any prior or subsequent occurrence.

- H. **Amendment.** Except as expressly provided otherwise herein, this Agreement may not be amended without the express written consent of both Parties.
- I. **Severability.** Any term or provision of this Agreement that is invalid or unenforceable in any situation in any jurisdiction shall not affect the validity or enforceability of the remaining terms and provisions hereof or the validity or enforceability of the offending term or provision in any other situation or in any other jurisdiction.
- J. **Release of Information and Advertising.** Consultant shall not, without the prior written consent of District, make any news release or other public disclosure regarding this Project.
- K. **Construction.** The Parties have participated jointly in the negotiation and drafting of this Agreement. In the event an ambiguity or question of intent or interpretation arises, this Agreement shall be construed as if drafted jointly by the Parties and no presumption or burden of proof shall arise favoring or disfavoring any Party by virtue of the authorship of any of the provisions of this Agreement. Any reference to any federal, state, local, or foreign statute or law shall be deemed also to refer to all rules and regulations promulgated thereunder, unless the context requires otherwise. The word "including" shall mean including without limitation.
- L. **Attorneys' Fees.** If any legal action is necessary to enforce or interpret the terms of this Agreement, the prevailing party shall be entitled to reasonable attorneys' fees, reasonable expert witness fees, costs, and necessary disbursements in addition to any other relief to which that party may be entitled.

IN WITNESS WHEREOF, the Parties have executed is Agreement to be effective on the day and year first above written.

YUCAIPA VALLEY WATER DISTRICT

Dated: _____ By: _____
Chris Mann, Board President

CONSULTANT

Dated: _____ By: _____

Print Name: _____

Print Title: _____

Attachment A - Scope of Work

Attachment B - Fee Proposal

Attachment C - Schedule

DRAFT



Date: November 16, 2021 **Task:** Not Applicable

Prepared By: Joseph B. Zoba, General Manager

Subject: Consideration of Resolutions Authorizing the Grant Application, Acceptance and Execution for Various Projects for Funding from the Urban and Multibenefit Drought Relief Program

Recommendation: That the Board adopts Resolution Nos. 2021-55, 2021-56, 2021-57, and 2021-58.

The California Department of Water Resources recently released the Urban and Multibenefit Drought Relief Program to provide financial assistance to address drought impacts through the implementation of projects with multiple benefits:

- For communities, including Tribes, facing the loss or contamination of their water supplies due to the drought; and
- To address immediate drought impacts on human health and safety, and to protect fish and wildlife resources plus other public benefits, such as ecosystem improvements.

Funding for the Program was authorized by the Legislature pursuant to the [Budget Act of 2021](#) and its Trailer Bill, [Assembly Bill 148](#).

The District staff has identified the following projects as meeting the requirements for this funding opportunity:

- North Bench Recycled Water Facilities - The proposed expansion of the recycled water system on the North Bench would involve the construction of three recycled water reservoirs, three booster stations, and about 3.5 miles of recycled water pipelines.
- Reconstruction of Well No. 24 and 5th Street Recycled Water Fill Station - Well No. 24 is one of the older wells operated by the District in the Calimesa subbasin of the Yucaipa Groundwater Basin. This project would involve the redrilling of Well No. 24 to eliminate the nitrate infiltration into the drinking water supply and the construction of a new recycled water fill station at the same location.

2021
Urban and
Multibenefit
Drought Relief
Grant Program

Guidelines and
Proposal
Solicitation
Package

Published: October 2021



- Construction of the R-12.5 Recycled Water Reservoirs - The R-12.5 Recycled Water Reservoirs will be located north of Cherry Valley Boulevard to support the recycled water service provided to dual-plumbed homes in the southern portion of the District's service area.
- Salinity Concentrate Reduction and Minimization (SCRAM) Project - The Salinity Concentrate Reduction and Minimization (SCRAM) Project expands the existing microfiltration system from 13.6 million gallons per day to 19.4 million gallons per day by adding two additional microfiltration treatment systems. There will also be two additional nanofiltration systems to provide 6 million gallons per day of additional treatment. This proposed system will increase the nanofiltration system recovery from 85% to 95% saving an estimated 190 million gallons of water per year.

The attached resolutions will be added to the grant submittal packages for consideration by the Department of Water Resources.

RESOLUTION NO. 2021-55

**RESOLUTION OF THE YUCAIPA VALLEY WATER DISTRICT
AUTHORIZING THE GRANT APPLICATION, ACCEPTANCE, AND EXECUTION
FOR THE NORTH BENCH RECYCLED WATER PROJECT**

WHEREAS, Yucaipa Valley Water District proposes to implement the North Bench Recycled Water Project;

WHEREAS, Yucaipa Valley Water District has the legal authority and is authorized to enter into a funding agreement with the State of California; and

WHEREAS, Yucaipa Valley Water District intends to apply for grant funding from the California Department of Water Resources for the North Bench Recycled Water Project.

NOW, THEREFORE, the Board of Directors of the Yucaipa Valley Water District hereby RESOLVE, DETERMINE, and ORDER as follows:

- Section 1. That pursuant and subject to all of the terms and provisions of Budget Act of 2021 (Stats. 2021, ch. 240, § 80), the Yucaipa Valley Water District’s General Manager, or designee is hereby authorized and directed to prepare and file an application for funding with the Department of Water Resources, and take such other actions necessary or appropriate to obtain grant funding.
- Section 2. The Yucaipa Valley Water District’s General Manager, or designee is hereby authorized and directed to execute the funding agreement with the Department of Water Resources and any amendments thereto.
- Section 3. The Yucaipa Valley Water District’s General Manager, or designee is hereby authorized and directed to submit any required documents, invoices, and reports required to obtain grant funding.

PASSED, APPROVED and ADOPTED this 16th day of November 2021.

YUCAIPA VALLEY WATER DISTRICT

Chris Mann, President Board of Directors

ATTEST:

Joseph B. Zoba, General Manager

CERTIFICATION: I hereby certify that the foregoing Resolution was duly and regularly adopted by the Yucaipa Valley Water District at the meeting held on November 16, 2021, motion by Director _____ and seconded by Director _____, motion passed by the following vote:

AYES:

NOES:

ABSTAIN:

ABSENT

ATTEST:

Joseph B. Zoba, General Manager

RESOLUTION NO. 2021-56

**RESOLUTION OF THE YUCAIPA VALLEY WATER DISTRICT
AUTHORIZING THE GRANT APPLICATION, ACCEPTANCE, AND EXECUTION
FOR THE RECONSTRUCTION OF WELL NO. 24 AND 5TH STREET RECYCLED
WATER FILL STATION**

WHEREAS, Yucaipa Valley Water District proposes to implement the Reconstruction of Well No. 24 and 5th Street Recycled Water Fill Station Project;

WHEREAS, Yucaipa Valley Water District has the legal authority and is authorized to enter into a funding agreement with the State of California; and

WHEREAS, Yucaipa Valley Water District intends to apply for grant funding from the California Department of Water Resources for the Reconstruction of Well No. 24 and 5th Street Recycled Water Fill Station Project.

NOW, THEREFORE, the Board of Directors of the Yucaipa Valley Water District hereby RESOLVE, DETERMINE, and ORDER as follows:

- Section 1. That pursuant and subject to all of the terms and provisions of Budget Act of 2021 (Stats. 2021, ch. 240, § 80), the Yucaipa Valley Water District’s General Manager, or designee is hereby authorized and directed to prepare and file an application for funding with the Department of Water Resources, and take such other actions necessary or appropriate to obtain grant funding.
- Section 2. The Yucaipa Valley Water District’s General Manager, or designee is hereby authorized and directed to execute the funding agreement with the Department of Water Resources and any amendments thereto.
- Section 3. The Yucaipa Valley Water District’s General Manager, or designee is hereby authorized and directed to submit any required documents, invoices, and reports required to obtain grant funding.

PASSED, APPROVED and ADOPTED this 16th day of November 2021.

YUCAIPA VALLEY WATER DISTRICT

Chris Mann, President Board of Directors

ATTEST:

Joseph B. Zoba, General Manager

CERTIFICATION: I hereby certify that the foregoing Resolution was duly and regularly adopted by the Yucaipa Valley Water District at the meeting held on November 16, 2021, motion by Director _____ and seconded by Director _____, motion passed by the following vote:

AYES:

NOES:

ABSTAIN:

ABSENT

ATTEST:

Joseph B. Zoba, General Manager

RESOLUTION NO. 2021-57

**RESOLUTION OF THE YUCAIPA VALLEY WATER DISTRICT
AUTHORIZING THE GRANT APPLICATION, ACCEPTANCE, AND EXECUTION
FOR THE CONSTRUCTION OF THE R-12.5 RECYCLED WATER RESERVOIR
COMPLEX**

WHEREAS, Yucaipa Valley Water District proposes to implement the Construction of the R-12.5 Recycled Water Reservoir Complex;

WHEREAS, Yucaipa Valley Water District has the legal authority and is authorized to enter into a funding agreement with the State of California; and

WHEREAS, Yucaipa Valley Water District intends to apply for grant funding from the California Department of Water Resources for the Construction of the R-12.5 Recycled Water Reservoir Complex.

NOW, THEREFORE, the Board of Directors of the Yucaipa Valley Water District hereby RESOLVE, DETERMINE, and ORDER as follows:

- Section 1. That pursuant and subject to all of the terms and provisions of Budget Act of 2021 (Stats. 2021, ch. 240, § 80), the Yucaipa Valley Water District’s General Manager, or designee is hereby authorized and directed to prepare and file an application for funding with the Department of Water Resources, and take such other actions necessary or appropriate to obtain grant funding.
- Section 2. The Yucaipa Valley Water District’s General Manager, or designee is hereby authorized and directed to execute the funding agreement with the Department of Water Resources and any amendments thereto.
- Section 3. The Yucaipa Valley Water District’s General Manager, or designee is hereby authorized and directed to submit any required documents, invoices, and reports required to obtain grant funding.

PASSED, APPROVED and ADOPTED this 16th day of November 2021.

YUCAIPA VALLEY WATER DISTRICT

Chris Mann, President Board of Directors

ATTEST:

Joseph B. Zoba, General Manager

CERTIFICATION: I hereby certify that the foregoing Resolution was duly and regularly adopted by the Yucaipa Valley Water District at the meeting held on November 16, 2021, motion by Director _____ and seconded by Director _____, motion passed by the following vote:

AYES:

NOES:

ABSTAIN:

ABSENT

ATTEST:

Joseph B. Zoba, General Manager

RESOLUTION NO. 2021-58

**RESOLUTION OF THE YUCAIPA VALLEY WATER DISTRICT
AUTHORIZING THE GRANT APPLICATION, ACCEPTANCE, AND EXECUTION
FOR THE SALINITY CONCENTRATE, REDUCTION AND MINIMIZATION (SCRAM)
PROJECT**

WHEREAS, Yucaipa Valley Water District proposes to implement the Salinity Concentrate Reduction and Minimization (SCRAM) Project;

WHEREAS, Yucaipa Valley Water District has the legal authority and is authorized to enter into a funding agreement with the State of California; and

WHEREAS, Yucaipa Valley Water District intends to apply for grant funding from the California Department of Water Resources for the Salinity Concentrate Reduction and Minimization (SCRAM) Project.

NOW, THEREFORE, the Board of Directors of the Yucaipa Valley Water District hereby RESOLVE, DETERMINE, and ORDER as follows:

- Section 1. That pursuant and subject to all of the terms and provisions of Budget Act of 2021 (Stats. 2021, ch. 240, § 80), the Yucaipa Valley Water District’s General Manager, or designee is hereby authorized and directed to prepare and file an application for funding with the Department of Water Resources, and take such other actions necessary or appropriate to obtain grant funding.
- Section 2. The Yucaipa Valley Water District’s General Manager, or designee is hereby authorized and directed to execute the funding agreement with the Department of Water Resources and any amendments thereto.
- Section 3. The Yucaipa Valley Water District’s General Manager, or designee is hereby authorized and directed to submit any required documents, invoices, and reports required to obtain grant funding.

PASSED, APPROVED and ADOPTED this 16th day of November 2021.

YUCAIPA VALLEY WATER DISTRICT

Chris Mann, President Board of Directors

ATTEST:

Joseph B. Zoba, General Manager

CERTIFICATION: I hereby certify that the foregoing Resolution was duly and regularly adopted by the Yucaipa Valley Water District at the meeting held on November 16, 2021, motion by Director _____ and seconded by Director _____, motion passed by the following vote:

AYES:

NOES:

ABSTAIN:

ABSENT

ATTEST:

Joseph B. Zoba, General Manager

Board Reports and Comments



Yucaipa Valley Water District



FACTS ABOUT THE YUCAIPA VALLEY WATER DISTRICT

Service Area Size: 40 square miles (sphere of influence is 68 square miles)

Elevation Change: 3,140 foot elevation change (from 2,044 to 5,184 feet)

Number of Employees: 5 elected board members
72 full time employees

FY 2021-22 Operating Budget: Water Division - \$17,274,066
Sewer Division - \$13,136,249
Recycled Water Division - \$1,357,175

Number of Services: 14,440 drinking water connections serving 19,355 units
14,363 sewer connections serving 21,429 units
695 recycled water connections serving 845 units

Water System: 236 miles of drinking water pipelines
2,134 fire hydrants
27 reservoirs - 34 million gallons of storage capacity
18 pressure zones
3.376 billion gallon annual drinking water demand
Two water filtration facilities:
- 1 mgd at Oak Glen Surface Water Filtration Facility
- 12 mgd at Yucaipa Valley Regional Water Filtration Facility

Sewer System: 8.0 million gallon treatment capacity - current flow at 4.0 mgd
223 miles of sewer mainlines
4,643 sewer manholes
7 sewer lift stations
1.46 billion gallons of recycled water produced per year

Recycled Water: 32 miles of recycled water pipelines
5 reservoirs - 12 million gallons of storage
0.623 billion gallon annual recycled water demand

Brine Disposal: 2.2 million gallon desalination facility at sewer treatment plant
1.756 million gallons of Inland Empire Brine Line capacity
0.595 million gallons of treatment capacity in Orange County

Sustainability Plan: A Strategic Plan for a Sustainable Future: The Integration and Preservation of Resources, adopted on August 20, 2008.

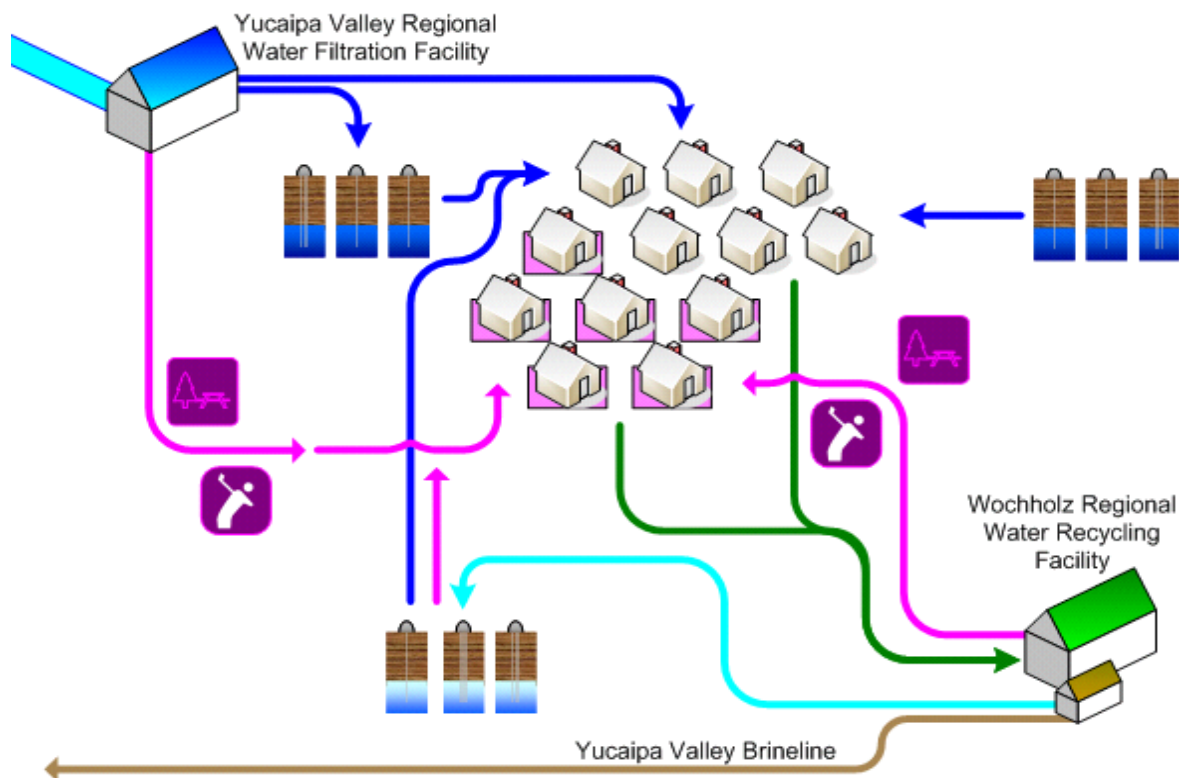

Typical Rates, Fees and Charges:

- Drinking Water Commodity Charge:

1,000 gallons to 15,000 gallons	\$1.626 per each 1,000 gallons
16,000 gallons to 60,000 gallons	\$2.419 per each 1,000 gallons
61,000 gallons to 100,000 gallons	\$2.508 per each 1,000 gallons
101,000 gallons or more	\$2.708 per each 1,000 gallons

- Recycled Water Commodity Charge:

1,000 gallons or more	\$1.795 per each 1,000 gallons
-----------------------	--------------------------------

- Water Meter Service Charge (Drinking Water or Recycled Water):

5/8" x 3/4" Water Meter	\$16.50 per month
1" Water Meter	\$27.56 per month
1-1/2" Water Meter	\$54.95 per month

- Sewer Collection and Treatment Charge:

Typical Residential Charge	\$44.52 per month
----------------------------	-------------------

State Water Contractors: San Bernardino Valley Municipal Water District
San Gorgonio Pass Water Agency



	San Bernardino Valley Municipal Water District	San Gorgonio Pass Water Agency
Service Area Size	353 square miles	222 square miles
Table "A" Water Entitlement	102,600 acre feet	17,300 acre feet
Imported Water Rate	\$125.80 / acre foot	\$399 / acre foot
Tax Rates for FY 2020-21	\$0.1300 per \$100	\$0.1750 per \$100
Number of Board Members	Five (5)	Seven (7)
Operating Budget FY 2021-22	\$52,506,150	\$14,019,000

Imported Water Charges (Pass-through State Water Project Charge)

- San Bernardino Valley Municipal Water District - Customers in San Bernardino County or City of Yucaipa pay a pass-through amount of \$0.270 per 1,000 gallons.
- San Gorgonio Pass Water Agency - Customers in Riverside County or City of Calimesa pay a pass-through amount of \$0.660 per 1,000 gallons. A rate change of up to \$0.857 per 1,000 gallons is pending future consideration by YVWD.





GLOSSARY OF COMMONLY USED TERMS

Every profession has specialized terms which generally evolve to facilitate communication between individuals. The routine use of these terms tends to exclude those who are unfamiliar with the particular specialized language of the group. Sometimes jargon can create communication cause difficulties where professionals in related fields use different terms for the same phenomena.

Below are commonly used water terms and abbreviations with commonly used definitions. If there is any discrepancy in definitions, the District's Regulations Governing Water Service is the final and binding definition.

Acre Foot of Water - The volume of water (325,850 gallons, or 43,560 cubic feet) that would cover an area of one acre to a depth of 1 foot.

Activated-Sludge Process - A secondary biological wastewater treatment process where bacteria reproduce at a high rate with the introduction of excess air or oxygen and consume dissolved nutrients in the wastewater.

Annual Water Quality Report - The document is prepared annually and provides information on water quality, constituents in the water, compliance with drinking water standards and educational material on tap water. It is also referred to as a Consumer Confidence Report (CCR).

Aquifer - The natural underground area with layers of porous, water-bearing materials (sand, gravel) capable of yielding a supply of water; see Groundwater basin.

Backflow - The reversal of water's normal direction of flow. When water passes through a water meter into a home or business it should not reverse flow back into the water mainline.

Best Management Practices (BMPs) - Methods or techniques found to be the most effective and practical means in achieving an objective. Often used in the context of water conservation.

Biochemical Oxygen Demand (BOD) - The amount of oxygen used when organic matter undergoes decomposition by microorganisms. Testing for BOD is done to assess the amount of organic matter in water.

Biosolids - Biosolids are nutrient rich organic and highly treated solid materials produced by the wastewater treatment process. This high-quality product can be recycled as a soil amendment on farmland or further processed as an earth-like product for commercial and home gardens to improve and maintain fertile soil and stimulate plant growth.

Capital Improvement Program (CIP) - Projects for repair, rehabilitation, and replacement of assets. Also includes treatment improvements, additional capacity, and projects for the support facilities.

Certificate of Participation (COP) – A type of financing where an investor purchases a share of the lease revenues of a program rather than the bond being secured by those revenues.

Coliform Bacteria - A group of bacteria found in the intestines of humans and other animals, but also occasionally found elsewhere used as indicators of sewage pollution. E. coli are the most common bacteria in wastewater.

Collections System - In wastewater, it is the system of typically underground pipes that receive and convey sanitary wastewater or storm water.

Conjunctive Use - The coordinated management of surface water and groundwater supplies to maximize the yield of the overall water resource. Active conjunctive use uses artificial recharge, where surface water is intentionally percolated or injected into aquifers for later use. Passive conjunctive use is to simply rely on surface water in wet years and use groundwater in dry years.

Consumer Confidence Report (CCR) - see Annual Water Quality Report.

Contaminants of Potential Concern (CPC) - Pharmaceuticals, hormones, and other organic wastewater contaminants.

Cross-Connection - The actual or potential connection between a potable water supply and a non-potable source, where it is possible for a contaminant to enter the drinking water supply.

Disinfection by-Products (DBPs) - The category of compounds formed when disinfectants in water systems react with natural organic matter present in the source water supplies. Different disinfectants produce different types or amounts of disinfection byproducts. Disinfection byproducts for which regulations have been established have been identified in drinking water, including trihalomethanes, haloacetic acids, bromate, and chlorite

Drought - a period of below average rainfall causing water supply shortages.

Fire Flow - The ability to have a sufficient quantity of water available to the distribution system to be delivered through fire hydrants or private fire sprinkler systems.

Gallons per Capita per Day (GPCD) - A measurement of the average number of gallons of water use by the number of people served each day in a water system. The calculation is made by dividing the total gallons of water used each day by the total number of people using the water system.

Groundwater Basin - An underground body of water or aquifer defined by physical boundaries.

Groundwater Recharge - The process of placing water in an aquifer. Can be a naturally occurring process or artificially enhanced.

Hard Water - Water having a high concentration of minerals, typically calcium and magnesium ions.

Hydrologic Cycle - The process of evaporation of water into the air and its return to earth in the form of precipitation (rain or snow). This process also includes transpiration from plants, percolation into the ground, groundwater movement, and runoff into rivers, streams, and the ocean; see Water cycle.

Levels of Service (LOS) - Goals to support environmental and public expectations for performance.

Mains, Distribution - A network of pipelines that delivers water (drinking water or recycled water) from transmission mains to residential and commercial properties, usually pipe diameters of 4" to 16".

Mains, Transmission - A system of pipelines that deliver water (drinking water or recycled water) from a source of supply to the distribution mains, usually pipe diameters of greater than 16".

Meter - A device capable of measuring, in either gallons or cubic feet, a quantity of water delivered by the District to a service connection.

Overdraft - The pumping of water from a groundwater basin or aquifer in excess of the supply flowing into the basin. This pumping results in a depletion of the groundwater in the basin which has a net effect of lowering the levels of water in the aquifer.

Pipeline - Connected piping that carries water, oil, or other liquids. See Mains, Distribution and Mains, Transmission.

Point of Responsibility, Metered Service - The connection point at the outlet side of a water meter where a landowner's responsibility for all conditions, maintenance, repairs, use and replacement of water service facilities begins, and the District's responsibility ends.

Potable Water - Water that is used for human consumption and regulated by the California Department of Public Health.

Pressure Reducing Valve - A device used to reduce the pressure in a domestic water system when the water pressure exceeds desirable levels.

Pump Station - A drinking water or recycled water facility where pumps are used to push water up to a higher elevation or different location.

Reservoir - A water storage facility where water is stored to be used at a later time for peak demands or emergencies such as fire suppression. Drinking water and recycled water systems will typically use concrete or

steel reservoirs. The State Water Project system considers lakes, such as Shasta Lake and Folsom Lake to be water storage reservoirs.

Runoff - Water that travels downward over the earth's surface due to the force of gravity. It includes water running in streams as well as over land.

Santa Ana River Interceptor (SARI) Line - A regional brine line designed to convey 30 million gallons per day (MGD) of non-reclaimable wastewater from the upper Santa Ana River basin to Orange County Sanitation District for treatment, use and/or disposal.

Secondary treatment - Biological wastewater treatment, particularly the activated-sludge process, where bacteria and other microorganisms consume dissolved nutrients in wastewater.

Service Connection - The water piping system connecting a customer's system with a District water main beginning at the outlet side of the point of responsibility, including all plumbing and equipment located on a parcel required for the District's provision of water service to that parcel.

Sludge - Untreated solid material created by the treatment of wastewater.

Smart Irrigation Controller - A device that automatically adjusts the time and frequency which water is applied to landscaping based on real-time weather such as rainfall, wind, temperature, and humidity.

South Coast Air Quality Management District (SCAQMD) - Regional regulatory agency that develops plans and regulations designed to achieve public health standards by reducing emissions from business and industry.

Special district - A form of local government created by a local community to meet a specific need. Yucaipa Valley Water District is a County Water District formed pursuant to Section 30000 of the California Water Code

Supervisory Control and Data Acquisition (SCADA) - A computerized system which provides the ability to remotely monitor and control water system facilities such as reservoirs, pumps, and other elements of water delivery.

Surface Water - Water found in lakes, streams, rivers, oceans, or reservoirs behind dams. In addition to using groundwater, Yucaipa Valley Water District receives surface water from the Oak Glen area.

Sustainable Groundwater Management Act (SGMA) - Pursuant to legislation signed by Governor Jerry Brown in 2014, the Sustainable Groundwater Management Act requires water agencies to manage groundwater extractions to not cause undesirable results from over production.

Transpiration - The process by which water vapor is released into the atmosphere by living plants.

Trickling filter - A biological secondary treatment process in which bacteria and other microorganisms, growing as slime on the surface of rocks or plastic media, consume nutrients in wastewater as it trickles over them.

Underground Service Alert (USA) - A free service (<https://www.digalert.org>) that notifies utilities such as water, telephone, cable and sewer companies of pending excavations within the area (dial 8-1-1 at least 2 working days before you dig).

Urban runoff - Water from city streets and domestic properties that carry pollutants into the storm drains, rivers, lakes, and oceans.

Valve - A device that regulates, directs, or controls the flow of water by opening, closing, or partially obstructing various passageways.

Wastewater - Any water that enters the sanitary sewer.

Water Banking - The practice of actively storing or exchanging in-lieu surface water supplies in available groundwater basin storage space for later extraction and use by the storing party or for sale or exchange to a third party. Water may be banked as an independent operation or as part of a conjunctive use program.

Water Cycle - The continuous movement water from the earth's surface to the atmosphere and back again.

Water Pressure - Water pressure is created by the weight and elevation of water and/or generated by pumps that deliver water to customers.

Water Service Line - A water service line is used to deliver water from the Yucaipa Valley Water District's mainline distribution system.

Water table - the upper surface of the zone of saturation of groundwater in an unconfined aquifer.

Water transfer - a transaction, in which a holder of a water right or entitlement voluntarily sells/exchanges to a willing buyer the right to use all or a portion of the water under that water right or entitlement.

Watershed - A watershed is the region or land area that contributes to the drainage or catchment area above a specific point on a stream or river.

Water-Wise House Call - a service which provides a custom evaluation of a customer's indoor and outdoor water use and landscape watering requirements.

Well - a hole drilled into the ground to tap an underground aquifer.

Wetlands - lands which are fully saturated or under water at least part of the year, like seasonal vernal pools or swamps.

WIFIA - Water Infrastructure Finance and Innovation Act. The WIFIA program administered by the Environmental Protection Agency accelerates investment in our nation's water infrastructure by providing long-term, low-cost supplemental loans for regionally and nationally significant projects.





COMMONLY USED ABBREVIATIONS

AQMD	Air Quality Management District
BOD	Biochemical Oxygen Demand
CARB	California Air Resources Board
CCTV	Closed Circuit Television
CWA	Clean Water Act
EIR	Environmental Impact Report
EPA	U.S. Environmental Protection Agency
FOG	Fats, Oils, and Grease
GPD	Gallons per day
MGD	Million gallons per day
O & M	Operations and Maintenance
OSHA	Occupational Safety and Health Administration
POTW	Publicly Owned Treatment Works
PPM	Parts per million
RWQCB	Regional Water Quality Control Board
SARI	Santa Ana River Inceptor
SAWPA	Santa Ana Watershed Project Authority
SBVMWD	San Bernardino Valley Municipal Water District
SCADA	Supervisory Control and Data Acquisition system
SGMA	Sustainable Groundwater Management Act
SSMP	Sanitary Sewer Management Plan
SSO	Sanitary Sewer Overflow
SWRCB	State Water Resources Control Board
TDS	Total Dissolved Solids
TMDL	Total Maximum Daily Load
TSS	Total Suspended Solids
WDR	Waste Discharge Requirements
WIFIA	Water Infrastructure Finance and Innovation Act
YVWD	Yucaipa Valley Water District